

Candidate Name

Centre Number

Candidate
Number

OXFORD CAMBRIDGE AND RSA EXAMINATIONS

**Advanced Subsidiary General Certificate of Education
Advanced General Certificate of Education**

MEI STRUCTURED MATHEMATICS

4754(B)

Applications of Advanced Mathematics (C4)

Section B: Comprehension

Thursday

16 JUNE 2005

Afternoon

Up to 1 hour

Additional materials:

Rough paper

MEI Examination Formulae and Tables (MF2)

TIME Up to 1 hour

INSTRUCTIONS TO CANDIDATES

- Write your name, centre number and candidate number in the spaces at the top of this page.
- Answer **all** the questions.
- Write your answers in the spaces provided on the question paper.
- You are permitted to use a graphical calculator in this paper.

INFORMATION FOR CANDIDATES

- The number of marks is given in brackets [] at the end of each question or part question.
- The insert contains the text for use with the questions.
- You may find it helpful to make notes and do some calculations as you read the passage.
- You are **not** required to hand in these notes with your question paper.
- You are advised that an answer may receive **no marks** unless you show sufficient detail of the working to indicate that a correct method is being used.
- The total number of marks for this section is 18.

For Examiner's Use	
Qu.	Mark
1	
2	
3	
4	
5	
6	
7	
Total	

This question paper consists of 4 printed pages and an insert.

- 1 Explain why the number 1836.108 for the ratio $\frac{\text{Rest mass of proton}}{\text{Rest mass of electron}}$ would be suitable for communication with other civilisations whereas neither the rest mass of the proton nor that of the electron would be. [2]

.....

.....

.....

- 2 A civilisation which works in base 5 sends out the first 6 digits of π as 3.032 32. Convert this to base 10. [2]

.....

.....

.....

.....

- 3 Complete this table to show the next 3 values of the iteration

$$x_{n+1} = kx_n(1 - x_n)$$

in the case when $k = 3.2$ and $x_0 = 0.5$. Give your answers to calculator accuracy. [1]

n	x_n
0	0.5
1	0.8
2	0.512
3	
4	
5	

4 Justify the statement that the equation in line 83,

$$\frac{\phi}{1} = \frac{1}{\phi - 1},$$

has the solution $\phi = \frac{1 \pm \sqrt{5}}{2}$.

[2]

.....
.....
.....
.....

5 Justify the statement in line 87 that

$$\frac{1}{\phi} = \frac{\sqrt{5} - 1}{2}.$$

[3]

.....
.....
.....
.....

6 A sequence is defined by

$$a_{n+1} = 2a_n + 3a_{n-1} \quad \text{with } a_1 = 1 \text{ and } a_2 = 1.$$

Using the method on page 5, show that the value to which the ratio of successive terms converges is 3.

[4]

.....
.....
.....
.....
.....
.....

- 7 Use the information in the article, including the value of Feigenbaum's number given in line 142, to predict an approximate value of k at which the bifurcation from 8 to 16 outcomes occurs for the iterative equation

$$x_{n+1} = kx_n(1 - x_n). \quad [4]$$

.....

.....

.....

.....

.....

.....

OXFORD CAMBRIDGE AND RSA EXAMINATIONS

**Advanced Subsidiary General Certificate of Education
Advanced General Certificate of Education**

MEI STRUCTURED MATHEMATICS
Applications of Advanced Mathematics (C4)
Section B: Comprehension
INSERT

4754(B)

Thursday

16 JUNE 2005

Afternoon

Up to 1 hour

INSTRUCTIONS TO CANDIDATES

- This insert contains the text for use with the questions.

This insert consists of 8 printed pages.

Communicating with other civilisations

Background

From time immemorial, people have looked into the night sky and wondered whether there are other civilisations out there. During the last hundred years, it has become a theoretical possibility that, if such civilisations do exist, we could communicate with them. 5

This article looks at some ideas as to how such communication might get started.

First contact

Imagine then that we have reason to think that a planet orbiting a star some light years away might be home to intelligent life. We have no idea what form that life might take, let alone how their society might work. 10

Natural curiosity means that we would try to make contact with them by sending some sort of message. There would be two requirements.

- (i) The message would have to be such that it could be understood anywhere, and so free of any human or Earth-related influence.
- (ii) We would want to know whether the message had been received and understood, so it would have to invite a reply. 15

Many people believe that mathematics is the only universal culture-free language on Earth. So it would be appropriate to use it as a basis for first contact.

One suggestion is that we should transmit the first 5 (say) digits of π , 3.1415. This could be done using short pulses, with a longer one for the decimal point, as illustrated in Fig. 1. 20

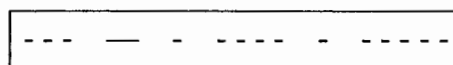

Fig. 1

We would then await a reply consisting of the next 5 digits, 92653.

Will they understand π ?

The number we call π arises because it is the ratio of the circumference to the diameter of a circle. It also occurs in many other aspects of mathematics.

An important point is that π requires no units. It is one length divided by another so that, provided the lengths are measured in the same units, the units cancel out. You get the same answer whether you measure the circumference and diameter in metres, feet, miles or anything else. Thus π is a pure number; it is dimensionless. 25

However, the digits we associate with π are dependent on our number system which uses base 10. If we used base 8, the first 6 digits of π would be 3.11037 since 30

$$\pi \approx 3 + \frac{1}{8} + \frac{1}{8^2} + \frac{0}{8^3} + \frac{3}{8^4} + \frac{7}{8^5},$$

compared with the base 10 equivalent of

$$\pi \approx 3 + \frac{1}{10} + \frac{4}{10^2} + \frac{1}{10^3} + \frac{5}{10^4} + \frac{9}{10^5}.$$

The reason we use base 10 is probably because we have a total of 10 fingers and thumbs. So another civilisation might well use a different number base. However, it is perhaps reasonable to assume that, if they are intelligent enough to communicate with us, they also have the sense to try out different number bases. 35

By communicating in base 10, we are telling the other civilisation that the number 10 is for some reason important in our culture.

A reply comes back 40

We would not, of course, send π just once. The other civilisation would almost certainly miss it! So we would keep on sending it until either we received a reply or we decided to give up. The nearest star is 4.3 light years away, so the soonest we could possibly get a reply would be 8.6 years. If, however, the star of interest was 50 light years away (not far in astronomical terms), the conversation would be even slower, once every 100 years. 45

The reply would almost certainly consist of two parts: the answer to our question (92653) and a question of their own. This might perhaps be the signal given in Fig. 2, representing the first 5 digits of e, the base of natural logarithms.

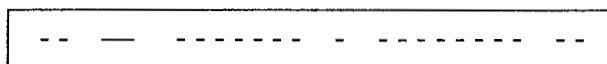

Fig. 2

Receiving this message would be one of the most exciting events in human history. Undoubtedly it would set off a lively debate about what to send next. It is reasonable to conjecture that three groups would be particularly interested. 50

- Military personnel would want to assess what the outcome would be if we were to find ourselves at war with the other civilisation.
- Others would want to find out about their culture.
- Scientists would hope to learn from them. 55

Military questions

The military would find themselves in considerable difficulty. They would want to assess the weapons capability of the other civilisation, and so would need to devise a sequence of different numbers (or questions) each of which related to a different stage of weapons development. 60

However, sending out such a sequence of numbers would be fraught with danger. The other civilisation might well work out the precise purpose of the questions and so deduce our own

level of military sophistication without giving away any information from their side. It could well be seen as sending out a hostile message with the possibility that the other civilisation would then break off communication.

65

So it is quite possible that direct military involvement would be seen as just too risky.

Cultural questions

The golden ratio

A number that would certainly be considered is the *golden ratio*. The sides of the rectangle in Fig. 3 are in the ratio 1.618... to 1. This is called the golden ratio and the number 1.618... is denoted by ϕ (the Greek letter phi). Such a rectangle is called a *golden rectangle*.

70

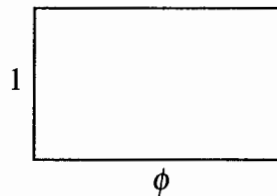

Fig. 3

The golden ratio has considerable cultural significance. For thousands of years a golden rectangle, like the one in Fig. 3, has been regarded as more pleasing to the eye than any other rectangle. So ϕ is related to our artistic sense.

To derive the number ϕ , look at the rectangle ABCD in Fig. 4. It is divided into two parts: a square EBCF at one end, and a smaller rectangle AEFD.

75

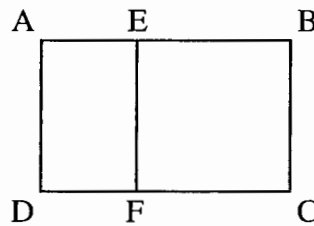

Fig. 4

If the ratio of the sides of the small rectangle AEFD is the same as that of ABCD, then ABCD is a golden rectangle. In this case,

$$\frac{AB}{AD} = \frac{AD}{AE} = \phi.$$

Thus, if the smaller side, AD, of the main rectangle is given a value of 1 unit, the longer side, AB, is ϕ units.

80

Since EBCF is a square, the length AE is $(\phi - 1)$ units, and so

$$\frac{\phi}{1} = \frac{1}{\phi - 1}$$

$$\Rightarrow \phi = \frac{1 \pm \sqrt{5}}{2}.$$

Since ϕ must be positive, it follows that the golden ratio is $\frac{1 + \sqrt{5}}{2}$ or 1.61803... .

85

Notice that if the longer side of a golden rectangle is assigned a length of 1 unit, the length of the shorter side is $\frac{1}{\phi} = \frac{\sqrt{5}-1}{2}$ units.

The number $\frac{1 + \sqrt{5}}{2}$ crops up in many other places in mathematics, including the Fibonacci sequence. This is usually written

$$1, 1, 2, 3, 5, 8, 13, 21, 34, 55, 89, \dots$$

90

The first two terms are both given the value 1. After that, each term is the sum of the previous two terms and so the sequence can be defined iteratively by

$$a_{n+1} = a_n + a_{n-1} \quad \text{with } a_1 = 1 \text{ and } a_2 = 1.$$

The ratios of one term to the previous term form the sequence

$$\frac{1}{1} = 1, \quad \frac{2}{1} = 2, \quad \frac{3}{2} = 1.5, \quad \frac{5}{3} = 1.666\dots, \quad \frac{8}{5} = 1.6,$$

$$\frac{13}{8} = 1.625, \quad \frac{21}{13} = 1.615\dots, \quad \frac{34}{21} = 1.619\dots, \quad \dots$$

95

This sequence converges and it looks as though its limit has the same value as ϕ .

To prove that it does, imagine that you have taken so many terms that the ratio has settled down to a value, r .

Thus
$$r = \frac{a_{n+1}}{a_n} \quad \text{and} \quad r = \frac{a_n}{a_{n-1}}.$$

100

Take the equation $a_{n+1} = a_n + a_{n-1}$ and divide through by a_n .

$$\frac{a_{n+1}}{a_n} = 1 + \frac{a_{n-1}}{a_n}$$

and so

$$r = 1 + \frac{1}{r}$$

$$\Rightarrow r^2 - r - 1 = 0$$

$$r = \frac{1 + \sqrt{5}}{2} \quad \left(\text{or } \frac{1 - \sqrt{5}}{2} \right).$$

105

The Fibonacci sequence occurs in nature, for example in connection with the numbers of petals on several types of flowers.

So the message conveyed to another civilisation by the number ϕ would not be unique. They might think we were telling them about our artistic sense, or about the flowers that grow on our planet or about something else.

110

Feigenbaum's number

A particularly interesting number to send is Feigenbaum's number. This was discovered in 1975 as a result of work on the (then) new subject of chaos.

A simple model for population growth is given by the *logistic equation*,

$$x_{n+1} = kx_n(1 - x_n),$$

115

where x_n is the population, on a scale of 0 to 1, at a certain time and x_{n+1} is the population one unit of time later. The starting point, x_0 , is a number between 0 and 1. The number k represents the reproductivity of the species in question; it is a *parameter* of the model.

This is an iterative process and the outcome depends on the value of k . For $0 \leq k \leq 1$, the values of x get progressively smaller and converge to zero. The population dies out, whatever the starting value. Table 5(a) illustrates this in the case $k = 0.3$ with starting value $x_0 = 0.5$.

120

For values of k between 1 and 3, the values of x converge to a particular value which depends on the value of k but not on the starting point. Thus when $k = 2.2$, x converges to 0.545 454 ... , as shown in Table 5(b). The population assumes a stable level.

$k = 0.3$	
n	x_n
0	0.5
1	0.075
2	0.020 812 ...
3	0.006 113 ...
4	0.001 822 ...
5	0.000 545 ...
6	0.000 163 ...
7	0.000 049 ...
8	0.000 014 ...
9	0.000 004 ...
10	0.000 001 ...
11	0.000 000 ...

Table 5(a)

$k = 2.2$	
n	x_n
0	0.5
1	0.55
2	0.544 5
3	0.545 643 ...
4	0.545 416 ...
5	0.545 462 ...
6	0.545 453 ...
7	0.545 454 ...
8	0.545 454 ...
9	0.545 454 ...
10	0.545 454 ...
11	0.545 454 ...

Table 5(b)

For values of k a little bigger than 3, the value of x ends up oscillating between two outcomes. Thus when $k = 3.2$, the value of x ends up oscillating between 0.513... and 0.799... . The population goes up and down regularly.

125

For slightly larger values of k , the value of x ends up oscillating between 4 or 8 outcomes.

Fig. 6 shows the outcomes for values of k between 1 and 3.55.

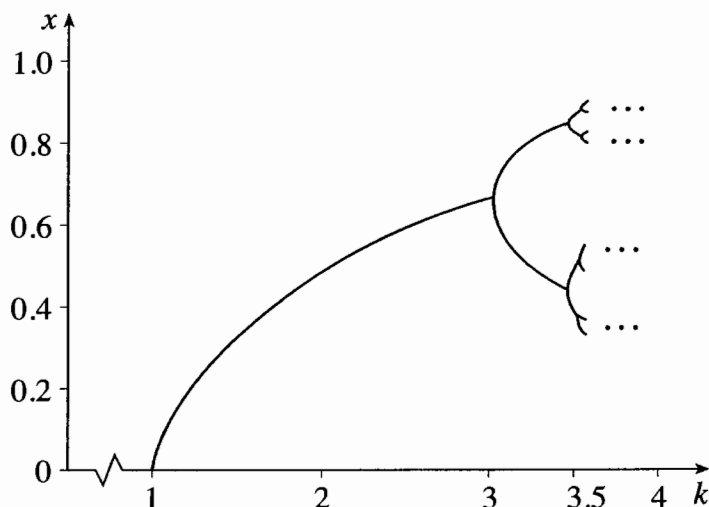

Fig. 6

Larger values of k than those illustrated in Fig. 6 produce even more outcomes, 16, 32 etc. The number of outcomes is always a power of 2. 130

For still larger values of k there is no pattern at all. The system goes into chaos.

When $k = 3$, there is a change of regime from one non-zero outcome to two. This is called a *point of bifurcation*.

The next point of bifurcation occurs when the number of outcomes changes from 2 to 4; it occurs at $k = 3.4485$ (to 4 decimal places). The one after that is at $k = 3.5437$ when the change is from 4 to 8, and so on. 135

Number of non-zero outcomes	1	2	4
Values of k	1 to 3	3 to 3.4485	3.4485 to 3.5437
Length of present interval	2	0.4485	0.0952
$\frac{\text{Previous interval}}{\text{Present interval}}$	—	$\frac{2}{0.4485} = 4.459\dots$	$\frac{0.4485}{0.0952} = 4.711\dots$

Table 7

Table 7 shows the intervals, in terms of the parameter k , for the first 3 regimes (excluding $0 \leq k \leq 1$ for which the population dies out). The final row gives the ratios of lengths of consecutive intervals. 140

What Feigenbaum discovered is that the sequence formed by the values of this ratio converges to a particular number, 4.669 201... . (Australian mathematicians have now computed it to 1000 significant figures.)

What is remarkable about Feigenbaum's number is that it arises not just in the iterative equation described above, but in a wide variety of equations modelling real-life situations which change from order into chaos. It is a universal constant. 145

For example, an entirely different iterative equation which generates Feigenbaum's number is

$$x_{n+1} = k \sin(\pi x_n).$$

The fact that 30 years ago we did not know about Feigenbaum's number, but do now, illustrates the point that it is a marker in our technological and cultural development. Its discovery depended on having the power of electronic calculation. The number and length of the calculations involved in its discovery were enormous. 150

So sending the first few digits of Feigenbaum's number to another civilisation could be taken as asking the question "Have you developed computers yet?" However, a positive response could also mean that those in the other civilisation have wonderfully good brains of their own, so good that they do not need computers. 155

Scientific questions

It would be a matter of great interest to scientists to find out whether quantities we believe to be constant really are: for example the velocity of light, $2.997\,924 \times 10^5$ kilometres per second. Even a small difference in this would require a fundamental re-think of the laws of physics. 160

Unfortunately this value uses units that are derived from conditions on Earth. The kilometre is approximately $\frac{1}{40\,000}$ of the circumference of the Earth, and the second is approximately $\frac{1}{60 \times 60 \times 24}$ of the time it takes the Earth to spin once on its axis (i.e. one day). Although both of these units are now defined more precisely using basic properties of matter, they retain essentially the same values and so would be meaningless to another civilisation. 165

It may be that the best that scientists could achieve would be certain ratios. For example

$$\frac{\text{Rest mass of proton}}{\text{Rest mass of electron}} = 1836.108.$$

The numbers scientists would send would almost certainly have been determined experimentally, to a known level of accuracy. If the reply came back with the same number but given to a much higher level of accuracy, it would be a good indication that the other civilisation is more technologically advanced than we are. 170

Thus it may be that the answers to science-based questions would tell us more about the civilisation's level of development than about science. 175

Conclusion

There are many other numbers that could be used in this context. No doubt a selection committee would be needed! The numbers mentioned in this article illustrate some of the principles which might guide the work of such a committee.

Candidate Name	Centre Number	Candidate Number



OXFORD CAMBRIDGE AND RSA EXAMINATIONS

**Advanced Subsidiary General Certificate of Education
Advanced General Certificate of Education**

MEI STRUCTURED MATHEMATICS

4754(B)

Applications of Advanced Mathematics (C4)

Paper B: Comprehension

Monday **23 JANUARY 2006** Afternoon Up to 1 hour

Additional materials:
Rough paper
MEI Examination Formulae and Tables (MF2)

TIME Up to 1 hour

INSTRUCTIONS TO CANDIDATES

- Write your name, centre number and candidate number in the spaces at the top of this page.
- Answer **all** the questions.
- Write your answers in the spaces provided on the question paper.
- You are permitted to use a graphical calculator in this paper.
- Final answers should be given to a degree of accuracy appropriate to the context.

INFORMATION FOR CANDIDATES

- The number of marks is given in brackets [] at the end of each question or part question.
- The insert contains the text for use with the questions.
- You may find it helpful to make notes and do some calculations as you read the passage.
- You are **not** required to hand in these notes with your question paper.
- You are advised that an answer may receive **no marks** unless you show sufficient detail of the working to indicate that a correct method is being used.
- The total number of marks for this section is 18.

For Examiner's Use	
Qu.	Mark
1	
2	
3	
4	
5	
Total	

This question paper consists of 5 printed pages, 3 blank pages and an insert.

- 1 Line 59 says “Again Party G just misses out; if there had been 7 seats G would have got the last one.”

Where is the evidence for this in the article? [1]

.....

- 2 6 parties, P, Q, R, S, T and U take part in an election for 7 seats. Their results are shown in the table below.

Party	Votes (%)
P	30.2
Q	11.4
R	22.4
S	14.8
T	10.9
U	10.3

- (i) Use the Trial-and-Improvement method, starting with values of 10% and 14%, to find an acceptance percentage for 7 seats, and state the allocation of the seats. [4]

Acceptance percentage, $a\%$	10%	14%			
Party	Votes (%)	Seats	Seats	Seats	Seats
P	30.2				
Q	11.4				
R	22.4				
S	14.8				
T	10.9				
U	10.3				
Total seats					

Seat Allocation P Q R S T U

(ii) Now apply the d'Hondt Formula to the same figures to find the allocation of the seats. [5]

Party	Round							Residual
	1	2	3	4	5	6	7	
P	30.2							
Q	11.4							
R	22.4							
S	14.8							
T	10.9							
U	10.3							
Seat allocated to								

Seat Allocation P Q R S T U

3 In this question, use the figures for the example used in Table 5 in the article, the notation described in the section “Equivalence of the two methods” and the value of 11 found for *a* in Table 4.

Treating Party E as Party 5, verify that $\frac{V_5}{N_5 + 1} < a \leq \frac{V_5}{N_5}$. [2]

.....

.....

.....

.....

.....

4 Some of the intervals illustrated by the lines in the graph in Fig. 8 are given in this table.

Seats	Interval	Seats	Interval
1	$22.2 < a \leq 27.0$	5	
2	$16.6 < a \leq 22.2$	6	$10.6 < a \leq 11.1$
3		7	
4			

(i) Describe briefly, giving an example, the relationship between the end-points of these intervals and the values in Table 5, which is reproduced below. [2]

.....

.....

.....

(ii) Complete the table above. [1]

Party	Round						Residual
	1	2	3	4	5	6	
A	22.2	22.2	11.1	11.1	11.1	11.1	7.4
B	6.1	6.1	6.1	6.1	6.1	6.1	6.1
C	27.0	13.5	13.5	13.5	9.0	9.0	9.0
D	16.6	16.6	16.6	8.3	8.3	8.3	8.3
E	11.2	11.2	11.2	11.2	11.2	5.6	5.6
F	3.7	3.7	3.7	3.7	3.7	3.7	3.7
G	10.6	10.6	10.6	10.6	10.6	10.6	10.6
H	2.6	2.6	2.6	2.6	2.6	2.6	2.6
Seat allocated to	C	A	D	C	E	A	

Table 5

5 The ends of the vertical lines in Fig. 8 are marked with circles. Those at the tops of the lines are filled in, e.g. ●, whereas those at the bottom are not, e.g. ○.

(i) Relate this distinction to the use of inequality signs. [1]

.....

(ii) Show that the inequality on line 102 can be rearranged to give $0 \leq V_k - N_k a < a$. [1]

.....

.....

.....

.....

(iii) Hence justify the use of the inequality signs in line 102. [1]

.....

.....

.....

.....

OXFORD CAMBRIDGE AND RSA EXAMINATIONS

**Advanced Subsidiary General Certificate of Education
Advanced General Certificate of Education**

MEI STRUCTURED MATHEMATICS

4754(B)

Applications of Advanced Mathematics (C4)

Paper B: Comprehension

INSERT

Monday

23 JANUARY 2006

Afternoon

Up to 1 hour

INSTRUCTIONS TO CANDIDATES

- This insert contains the text for use with the questions.

This insert consists of 8 printed pages.

Electing Members of the European Parliament

The Regional List System

The British members of the European Parliament are elected using a form of proportional representation called the Regional List System. This article compares two different ways of working out who should be elected.

Great Britain is divided into 11 regions and each of these is assigned a number of seats in the European Parliament. So, for example, the South West region has 7 seats, meaning that it elects 7 members to the parliament. 5

Each political party in a region presents a list of candidates in order of preference. For example, in a region with 5 seats, Party A could present a list like that in Table 1.

	Party A
1	Comfort Owosu
2	Graham Reid
3	Simon White
4	Malini Ghosh
5	Sam Roy

Table 1

According to the proportion of the votes that Party A receives, 0, 1, 2, 3, 4 or all 5 of the people on the list may be elected. 10

Imagine an election for 6 seats in one region. It is contested by 8 political parties, A, B, C, D, E, F, G and H and the percentages of votes they receive are given in Table 2.

Party	Votes (%)
A	22.2
B	6.1
C	27.0
D	16.6
E	11.2
F	3.7
G	10.6
H	2.6

Table 2

How do you decide which parties get the 6 seats?

The Trial-and-Improvement method

15

The Regional List System is based on the idea that, in any particular regional election, a certain percentage of votes will win one seat. In this article, this is called the *acceptance percentage* and is denoted by $a\%$. A party which receives less than $a\%$ of the votes is given no seats; one that receives at least $a\%$ and less than $2a\%$ of the votes gets 1 seat; at least $2a\%$ and less than $3a\%$ of the votes translates into 2 seats and so on.

20

At first sight it might seem that, in the example in Table 2, since $100\% \div 6 = 16\frac{2}{3}\%$, the acceptance percentage should be about 16.7% of the votes. Clearly that will not work since it would give Parties A and C one seat each and none of the others would get any. Only 2 members would be elected rather than the required 6.

So what percentage of the votes is needed for exactly 6 people to be elected? One method of deciding is to try out different possible acceptance percentages and find one which results in 6 seats. In Table 3, values of a of 8, 10, 12 and 14 are tried out.

25

Acceptance percentage, $a\%$		8%	10%	12%	14%
Party	Votes (%)	Seats	Seats	Seats	Seats
A	22.2	2	2	1	1
B	6.1	0	0	0	0
C	27.0	3	2	2	1
D	16.6	2	1	1	1
E	11.2	1	1	0	0
F	3.7	0	0	0	0
G	10.6	1	1	0	0
H	2.6	0	0	0	0
Total seats		9	7	4	3

Table 3

Table 3 shows that an acceptance percentage of 10% is too low for 6 seats and one of 12% is too high. So it is natural to try 11% . This is shown in Table 4.

Party	Votes (%)	<i>a</i> % = 11 %	Used Votes (%)	Unused Votes (%)
		Seats		
A	22.2	2	22	0.2
B	6.1	0	0	6.1
C	27.0	2	22	5.0
D	16.6	1	11	5.6
E	11.2	1	11	0.2
F	3.7	0	0	3.7
G	10.6	0	0	10.6
H	2.6	0	0	2.6
Total		6	66.0%	34.0%

Table 4

Table 4 shows that an acceptance percentage of 11% gives 2 seats each to Parties A and C and one each to D and E, making a total of 6 in all. Party G just misses out. Thus with these voting figures, and with 6 seats to be allocated, 11% is a suitable acceptance percentage.

30

This Trial-and-Improvement method involves finding an interval within which the acceptance percentage must lie, in this example between 10% and 12%, and then closing in on a suitable value. It is like solving an equation by a change of sign method, but with the difference that in this case there is a range of possible answers: in the example above any value greater than 10.6% up to and including 11.1% will give a satisfactory acceptance percentage.

35

The range of values that an acceptance percentage can take depends on the number of seats.

The d'Hondt Formula

A different method of allocation is provided by the d'Hondt Formula. This is illustrated in Table 5, using the same data as before.

40

Party	Round						Residual
	1	2	3	4	5	6	
A	22.2	22.2	11.1	11.1	11.1	11.1	7.4
B	6.1	6.1	6.1	6.1	6.1	6.1	6.1
C	27.0	13.5	13.5	13.5	9.0	9.0	9.0
D	16.6	16.6	16.6	8.3	8.3	8.3	8.3
E	11.2	11.2	11.2	11.2	11.2	5.6	5.6
F	3.7	3.7	3.7	3.7	3.7	3.7	3.7
G	10.6	10.6	10.6	10.6	10.6	10.6	10.6
H	2.6	2.6	2.6	2.6	2.6	2.6	2.6
Seat allocated to	C	A	D	C	E	A	

Table 5

The d'Hondt Formula provides an algorithm in which seats are allocated from the top down. Each time a party is allocated a seat its vote is replaced by $\frac{V}{n+1}$, where V is the percentage of votes it received originally and n is the number of seats it has now been allocated.

- In Round 1, Party C has the highest percentage, 27.0, so C gets the first seat. 45
- For Round 2, the vote for Party C is divided by $(n+1)$, with n taking the value 1 since the party has now been allocated 1 seat. So the figure 27.0 for C is replaced by $27.0 \div 2 = 13.5$.
- The highest figure in Round 2 is 22.2 for Party A and so the next seat goes to A. The figure 22.2 for A is replaced by $22.2 \div 2 = 11.1$ in Round 3. The seat for Round 3 is allocated to Party D. 50
- In Round 4, Party C gets a second seat so that the value of n for this party is now 2. So the original figure for C is now divided by $(2+1) = 3$ for Round 5; $27.0 \div 3 = 9.0$.
- The figures in the final column, headed "Residual", are those that would be used if an extra seat were to be allocated. They do not have the same meaning as "Unused Votes" in Table 4. 55

In this example, the outcome obtained using the d'Hondt Formula is the same as that from the Trial-and-Improvement method, namely 2 seats each for A and C, and one each for D and E. Again Party G just misses out; if there had been 7 seats G would have got the last one.

Equivalence of the two methods 60

Since the two methods are completely different, it comes as something of a surprise that in this example they produce the same outcome. The question then arises as to whether they will always produce the same outcome.

The results of the real elections are worked out using the d'Hondt Formula; if there were circumstances in which this produced different outcomes from the Trial-and-Improvement method, there might be doubt about the fairness of the election. 65

It is, however, possible to show that the outcomes from the two methods will always be the same.

Before seeing how to do this, it is important to understand that there are fundamental differences between the methods. 70

- The Trial-and-Improvement method is based on finding an acceptance percentage for the particular number of seats; for a different number of seats you have to find a different acceptance percentage.
- Using the d'Hondt Formula, an acceptance percentage is never known. The method gives the outcome round by round for as many seats as are to be allocated. 75

In the Trial-and-Improvement method, call the parties Party 1, Party 2, ..., Party m .

Suppose that Party k receives $V_k\%$ of the votes and is allocated N_k seats.

6

One way of looking at this outcome is that each of the N_k elected members of parliament received an acceptance percentage of the votes, $a\%$, and then there were some “unused votes” left over, as shown in Table 4. 80

The percentage of unused votes must be less than the acceptance percentage; otherwise the party would have been allocated another seat.

Therefore
$$V_k - (N_k \times a) < a$$

and so
$$a > \frac{V_k}{N_k + 1}.$$

This is true for all the values of k from 1 to m . 85

A second condition arises for those parties that have been allocated seats. If such a party had been allocated one fewer seat, $N_k - 1$ instead of N_k , the percentage of votes left over would have been at least the acceptance percentage.

Therefore
$$V_k - (N_k - 1)a \geq a$$

and so
$$a \leq \frac{V_k}{N_k}.$$
 90

(If, however, a party has not been allocated any seats anyway, then there is no equivalent second inequality.)

Thus
$$\frac{V_k}{N_k + 1} < a \leq \frac{V_k}{N_k} \quad \text{if } N_k > 0$$

and
$$\frac{V_k}{N_k + 1} < a \quad \text{if } N_k = 0.$$

Now look at Table 6 below. This reproduces row C from Table 5 illustrating the d’Hondt Formula. 95

	Round						
Party	1	2	3	4	5	6	Residual
C	27.0	13.5	13.5	13.5	9.0	9.0	9.0
Seat allocated to	C			C			

Table 6

Using the notation above, with C as Party 3, this becomes Table 7.

	Round						
Party	1	2	3	4	5	6	Residual
C	V_3	$\frac{1}{2}V_3$	$\frac{1}{2}V_3$	$\frac{1}{2}V_3$	$\frac{1}{3}V_3$	$\frac{1}{3}V_3$	$\frac{1}{3}V_3$
Seat allocated to	C			C			

Table 7

So in this case the acceptance percentage lies between $\frac{1}{2}V_3$, which gives another seat in Round 4, and $\frac{1}{3}V_3$ which does not give another seat.

So
$$\frac{1}{3}V_3 < a \leq \frac{1}{2}V_3.$$

This result can be generalised by replacing Party 3 by Party k , and the 2 seats by N_k seats, to obtain the result found above for the Trial-and-Improvement method, 100

$$\frac{V_k}{N_k + 1} < a \leq \frac{V_k}{N_k}.$$

Thus the two methods are indeed equivalent.

Discovering the d'Hondt Formula

While the Trial-and-Improvement method is straightforward, the d'Hondt Formula is quite subtle, so much so that it is natural to ask "How did anyone think this up in the first place?" 105

The method owes its name to Victor d'Hondt, a Belgian lawyer and mathematician who first described it in 1878. It is used in many countries, including the United States where it is called the Jefferson Method.

The graph in Fig. 8 provides a clue as to how it might have been discovered. Fig. 8 shows the ranges of possible acceptance percentages for different numbers of seats, for the figures in Table 2. To draw such a graph, you need to work out the end-points of the various ranges. The range $10.6 < a \leq 11.1$ for the case of electing 6 people was given on line 37. These end-points turn out to be the largest numbers in successive Rounds in Table 5 which illustrates the d'Hondt Formula. Thus drawing this type of graph leads you into the d'Hondt Formula. 115

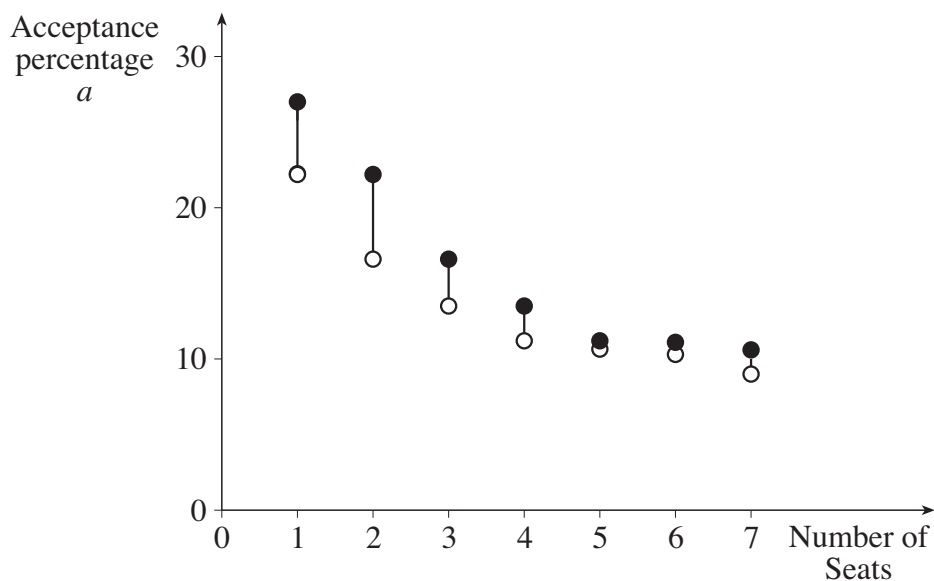

Fig. 8

Which is the better method?

Since the two methods are equivalent, there is no mathematical reason to declare either to be the better.

There are, however, two other considerations.

- Is one method easier than the other to apply? 120
- Is one method easier than the other for the public to understand, and so more likely to generate confidence in the outcome?

Candidate Name	Centre Number	Candidate Number



OXFORD CAMBRIDGE AND RSA EXAMINATIONS

**Advanced Subsidiary General Certificate of Education
Advanced General Certificate of Education**

MEI STRUCTURED MATHEMATICS

4754(B)

Applications of Advanced Mathematics (C4)

Paper B: Comprehension

Monday **12 JUNE 2006** Afternoon Up to 1 hour

Additional materials:
Rough paper
MEI Examination Formulae and Tables (MF2)

TIME Up to 1 hour

INSTRUCTIONS TO CANDIDATES

- Write your name, centre number and candidate number in the spaces at the top of this page.
- Answer **all** the questions.
- Write your answers in the spaces provided on the question paper.
- You are permitted to use a graphical calculator in this paper.

INFORMATION FOR CANDIDATES

- The number of marks is given in brackets [] at the end of each question or part question.
- The insert contains the text for use with the questions.
- You may find it helpful to make notes and do some calculations as you read the passage.
- You are **not** required to hand in these notes with your question paper.
- You are advised that an answer may receive **no marks** unless you show sufficient detail of the working to indicate that a correct method is being used.
- The total number of marks for this paper is 18.

For Examiner's Use	
Qu.	Mark
1	
2	
3	
4	
5	
6	
Total	

This question paper consists of 4 printed pages and an insert.

- 1 The marathon is 26 miles and 385 yards long (1 mile is 1760 yards). There are now several men who can run 2 miles in 8 minutes. Imagine that an athlete maintains this average speed for a whole marathon. How long does the athlete take? [2]

.....
.....
.....

- 2 According to the linear model, in which calendar year would the record for the men's mile first become negative? [3]

.....
.....
.....
.....
.....

- 3 Explain the statement in line 93 "According to this model the 2-hour marathon will never be run." [1]

.....
.....
.....

4 Explain how the equation in line 49,

$$R = L + (U - L)e^{-kt},$$

is consistent with Fig. 2

(i) initially, [3]

(ii) for large values of t . [2]

(i)
.....
.....

(ii)
.....
.....

[Questions 5 and 6 are printed overleaf.]

5 A model for an athletics record has the form

$$R = A - (A - B)e^{-kt} \text{ where } A > B > 0 \text{ and } k > 0.$$

(i) Sketch the graph of R against t , showing A and B on your graph. [3]

(ii) Name one event for which this might be an appropriate model. [1]

(i)

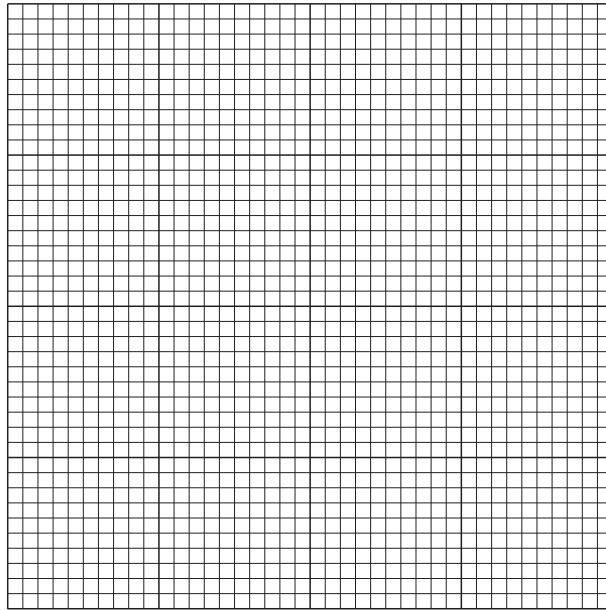

(ii)

6 A number of cases of the general exponential model for the marathon are given in Table 6. One of these is

$$R = 115 + (175 - 115)e^{-0.0467t^{0.797}}.$$

(i) What is the value of t for the year 2012? [1]

(ii) What record time does this model predict for the year 2012? [2]

(i)

(ii)

.....

.....

.....

OXFORD CAMBRIDGE AND RSA EXAMINATIONS

**Advanced Subsidiary General Certificate of Education
Advanced General Certificate of Education**

MEI STRUCTURED MATHEMATICS

4754(B)

Applications of Advanced Mathematics (C4)

Paper B: Comprehension

INSERT

Monday

12 JUNE 2006

Afternoon

Up to 1 hour

INSTRUCTIONS TO CANDIDATES

- This insert contains the text for use with the questions.

This insert consists of 11 printed pages and 1 blank page.

Modelling athletics records

Introduction

In the 1900 Olympic Games, shortly before world records were first kept, the record time for the marathon was almost exactly 3 hours. One hundred years later, in 2000, the world record stood at 2 hours 5 minutes and 42 seconds; it had been set during the previous year by Khalid Kannouchi of Morocco. At the time of writing this article, the world marathon record for men is 2 hours 4 minutes and 55 seconds, set by Paul Tergat of Kenya.

5

When will the marathon record fall below 2 hours?

It is clearly not possible to predict exactly when any world record will be broken, or when a particular time, distance or height will be achieved. It depends, among other things, on which athletes are on form at any time. However, it is possible to look at overall trends and so to make judgements about when new records are likely to be set.

10

Prediction inevitably involves extrapolating beyond existing data, and so into the unknown. If this is to be more than guesswork, it must be based on a suitable mathematical model.

It is reasonable to hope that a general model can be found, one that can be adapted to many athletics events. Such a model will take the form of a formula involving several parameters; these will take different values for different events. The parameter values will take account of the obvious distinction that, whereas records for track events (like the marathon and the mile) decrease with time, those for field events (like the long jump and the javelin) increase.

15

This article looks at possible formulae for such a model.

20

The linear model

The simplest type of model is linear and this is well illustrated by the men's mile. The graph in Fig. 1 shows the world record for the mile plotted against the year from 1915 to 2005. Details of these records are given in Appendix A.

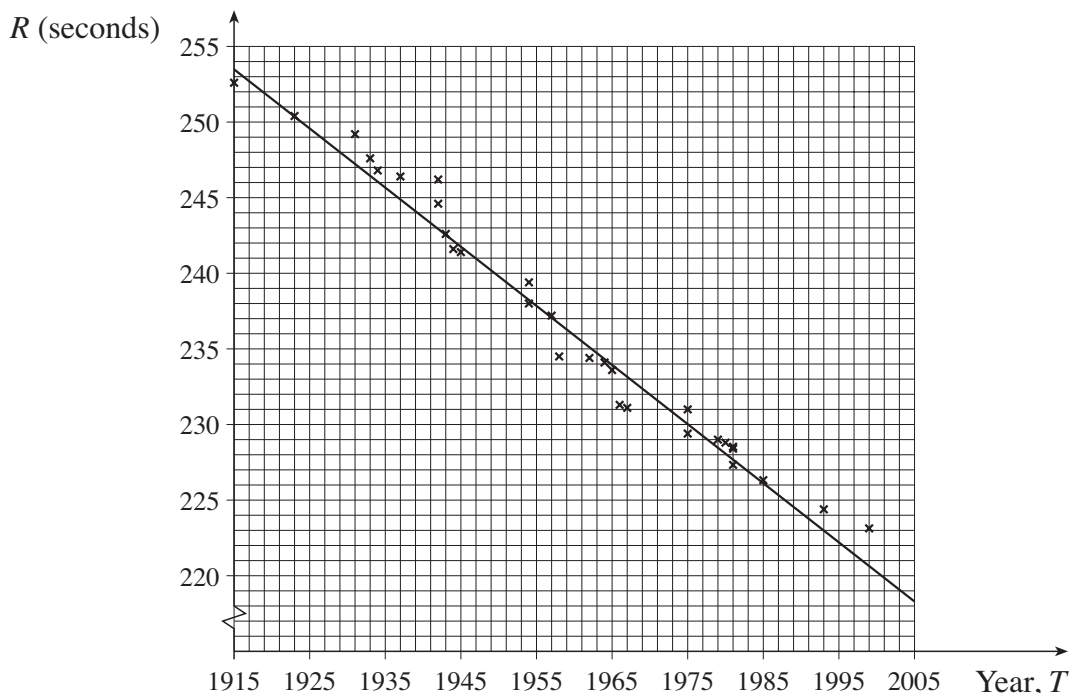

Fig. 1

A line of best fit has been drawn on Fig. 1. Its equation is

25

$$R = 259.6 - 0.391(T - 1900)$$

where

- R is the record time in seconds
- T is the calendar year.

(This equation was calculated using a standard statistical technique.)

30

The straight line clearly provides quite a good model for the record time between the years 1915 and 2005. However, it will not continue to do so for ever. For a sufficiently large value of T , the value of R will become negative, which is clearly impossible.

While the record time becoming negative shows that the linear model needs to be refined or replaced, there are also positive times that are quite unrealistic. Over the years, training methods have improved, as have running techniques and conditions, and no doubt this process will continue. However, there is a level of performance that will never be achieved by a human; for example, it seems highly unlikely that any human will ever run a mile in a time of 2 minutes. So, somewhere between the present record and 2 minutes, there is a certain time that will never quite be achieved, a lower bound for the record time. A good model needs to

35

40

The simple exponential model

In Fig. 2, such a lower bound is represented by the horizontal asymptote, $R = L$. You would expect the record time to approach the asymptote as a curve and this is also illustrated in Fig. 2.

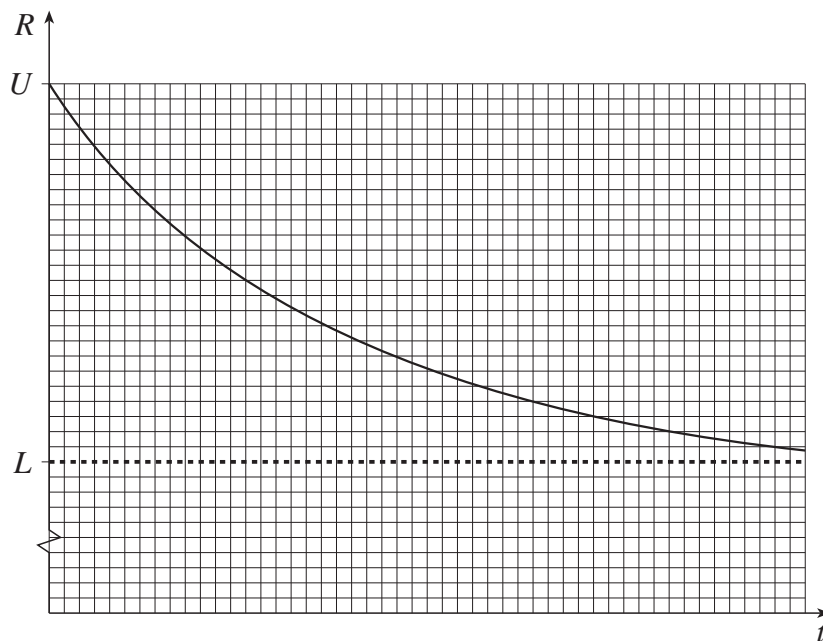

Fig. 2

The data for the mile (illustrated in Fig. 1) could correspond to a part of such a graph before it had flattened out. However, if you look again at Fig. 1, you may think that a gentle curve is more appropriate than the straight line, particularly for the more recent records.

45

A possible equation for such a model for the record time has the form

$$R = L + (U - L)e^{-kt}$$

where

50

- U (Upper) is the initial record
- L (Lower) is the value at the asymptote, as illustrated in Fig. 2
- t is the time that has elapsed since records began
- k is a positive constant.

Notice the distinction in this article between t and T . The symbol T has already been used in line 26.

55

- T denotes the calendar year (so for the present year $T = 2006$).

In this model the record time obeys a simple exponential law and so in this article it is referred to as the *simple exponential model*.

Applying the simple exponential model to the men's marathon

60

The graph in Fig. 3 shows the record times for the men's marathon from 1908, when world records began, to 2005. In this case the record time, R , is measured in minutes. (Details of the performances are given in Appendix B.) A "curve of best fit", in this case drawn by eye, has been superimposed.

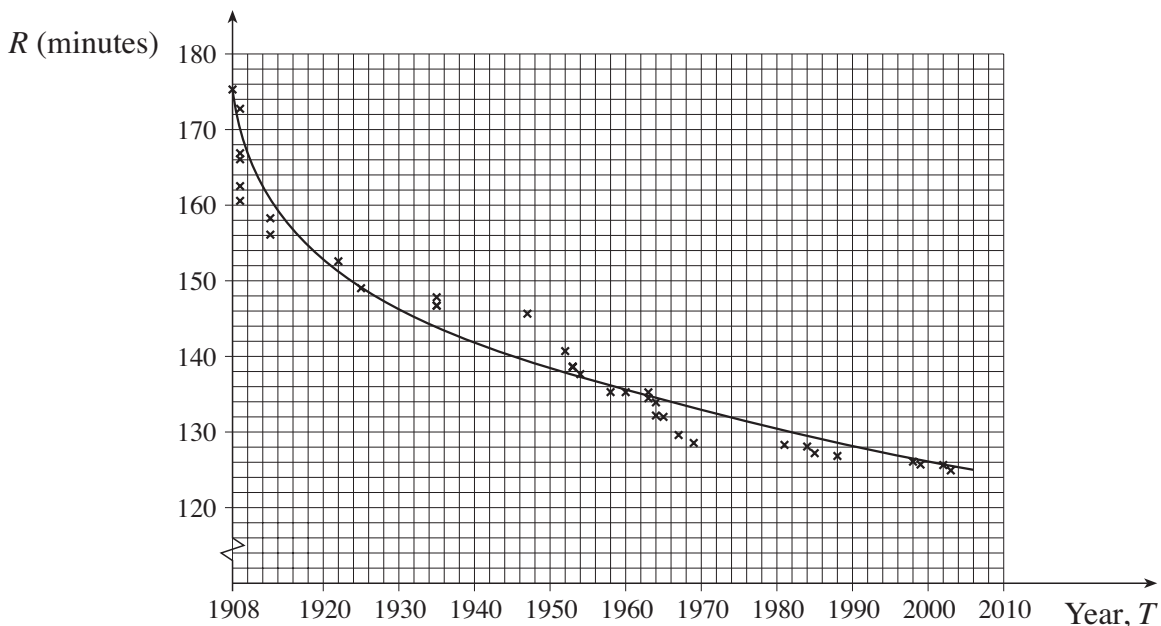

Fig. 3

There are 3 parameters in the equation for the simple exponential model, L , U and k . They will take different values for different athletics events. The values of the 3 parameters can be determined from the coordinates of 3 points on the curve, each point giving rise to one equation. It is easiest to solve the equations if the 3 points chosen correspond to the initial time (i.e. $t = 0$) and two equally spaced subsequent values of t . 65

For 1908, 1955 and 2002, the curve goes through the points corresponding to 70

$$\begin{array}{ll} t = 0 & R = 175 \\ t = 47 & R = 137 \\ t = 94 & R = 125.5. \end{array}$$

The first equation is

$$175 = L + (U - L)e^0, \quad \text{(Equation 1)} \quad \text{75}$$

and this can be simplified to give $U = 175$.

The other two equations are as follows.

$$137 = L + (175 - L)e^{-47k} \quad \text{(Equation 2)}$$

$$125.5 = L + (175 - L)e^{-94k} \quad \text{(Equation 3)}$$

Equation 2 can be rewritten as 80

$$e^{-47k} = \frac{137 - L}{175 - L}$$

and Equation 3 as

$$e^{-94k} = \frac{125.5 - L}{175 - L}.$$

Since $e^{-94k} = (e^{-47k})^2$, it follows that

$$\frac{125.5 - L}{175 - L} = \left(\frac{137 - L}{175 - L} \right)^2. \quad \text{85}$$

This equation can be solved to give $L = 120.5$ (correct to 1 decimal place).

Substituting for L , in either Equation 2 or 3, gives an equation in k . The solution is $k = 0.0254$ and so this model for the marathon record is

$$R = 120.5 + 54.5e^{-0.0254t}$$

and this can alternatively be written as 90

$$R = 120.5 + 54.5e^{-0.0254(T-1908)}$$

where T is the calendar year.

According to this model the 2-hour marathon will never be run.

When Roger Bannister ran the first 4-minute mile in 1954, there was speculation that this represented just about the limit of the capability of the human frame. Now 3 minutes 40 seconds would seem a possibility. So the prediction of the simple exponential model that the 2-hour marathon will never be run feels distinctly unrealistic. This raises questions about the suitability of the model being used.

95

The general exponential model

A more sophisticated exponential model is given by the equation

100

$$R = L + (U - L)e^{-kt^\alpha}.$$

In this model, the time t is raised to the power α , where $\alpha > 0$. So this model has 4 parameters, L , U , k and α . In this article it is referred to as the *general exponential model*. The previous simple exponential model was the special case when $\alpha = 1$.

The advantages of this new model are shown by comparing Figs. 4 and 5, for both of which L and U have been given the values 110 and 150 respectively. In Fig. 4, the simple exponential model is illustrated for different values of the parameter k in the family of curves given by the equation

105

$$R = 110 + (150 - 110)e^{-kt}.$$

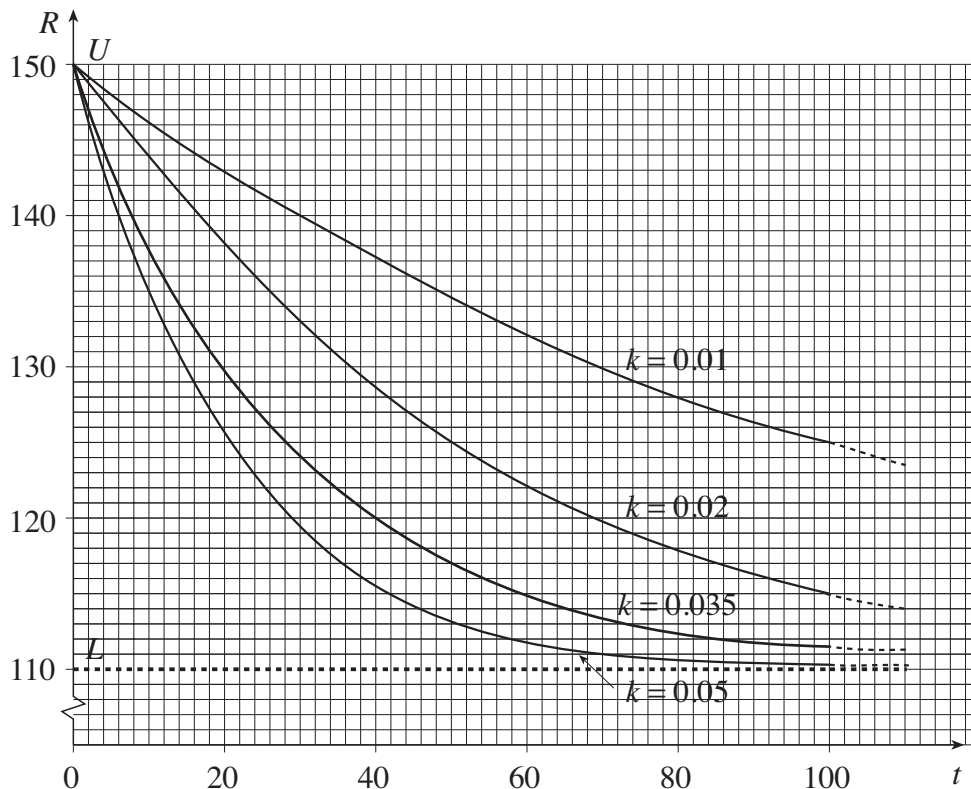

Fig. 4

All the curves approach the asymptote at $R = 110$ in essentially the same manner. (Each curve can be obtained from any other by applying a horizontal stretch.)

110

It is easy to see that, in Fig. 4, the value of k determines both the initial gradient and the subsequent path of the curve.

For this particular family
$$\frac{dR}{dt} = -40ke^{-kt}.$$

When $t = 0$
$$\frac{dR}{dt} = -40k,$$
 115

so that
$$k = -\frac{1}{40} \times \text{the initial gradient}.$$

Thus the simple exponential model is completely defined by the starting value, U , the lower bound, L , and the initial gradient.

By contrast the general exponential model allows variation in the shape of the curves. In Fig. 5, there are two curves. Curve A is an example of the simple exponential model and curve B of the general exponential model. Their equations are given by 120

$$\text{A: } R = 110 + (150 - 110)e^{-0.03t}$$

$$\text{B: } R = 110 + (150 - 110)e^{-0.134t^{0.5}}.$$

Both of these curves pass through the same initial point $(0, 150)$ and have the same horizontal asymptote $R = 110$. The horizontal asymptote is not shown in Fig. 5; instead the graph has been restricted to smaller values of t to show the differences between the two models more clearly. 125

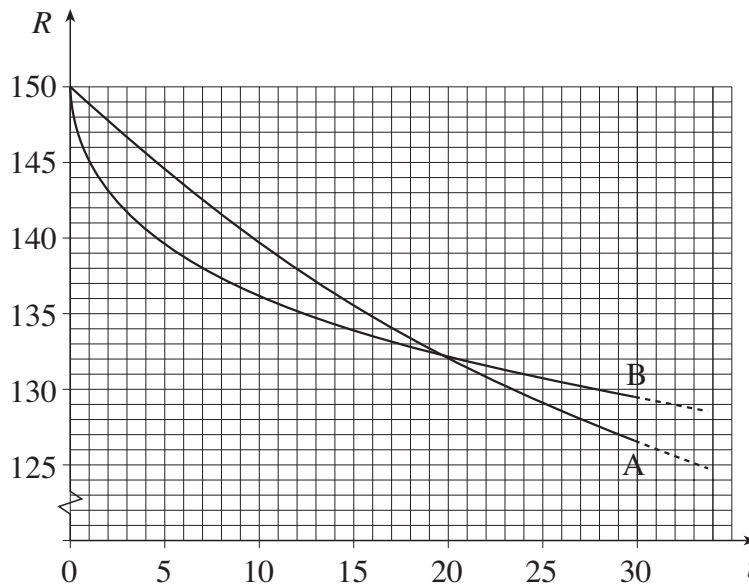

Fig. 5

With the given values for the parameters, according to the general exponential model (curve B) the record times initially fall more quickly than in the simple exponential model (curve A). At about $t = 20$, the two models give the same record time but after that the general exponential model is always further away from the asymptote. 130

The two curves in Fig. 5 are only examples. The values of the parameters were chosen to illustrate the different characteristics of the two models, and have no significance beyond that.

Experience shows that when a new event is introduced, for example the women's marathon in the early 1970s, records tend to decrease very rapidly for the first few years (or, of course, to increase for new field events). It is possible to allow for this in the general exponential model without getting close to the bound unrealistically soon. This is not the case with the simple exponential model. 135

So the general exponential model, with its 4 parameters, has the flexibility to provide a reasonable model for records. 140

With this model, it is also possible to address the concern expressed in lines 96 to 97 about the prediction for the men's marathon obtained from the simple exponential model.

For example, the general exponential curve through (0, 175), (47, 137) and (94, 125.5) with $k = 0.0467$ and $\alpha = 0.797$

- has its asymptote at 115 minutes rather than 120.5 minutes 145
- gives $R = 120$ when $t = 146$; this corresponds to the 2-hour marathon in the year 2054 rather than never.

In Table 6 a number of possible applications of the general exponential model to the men's marathon are listed. They all pass through the same 3 points as before, but have different values for the lower bound, L . 150

Lower bound, L , for marathon record	Model	Calendar year, T , for 2-hour marathon
115	$R = 115 + (175 - 115)e^{-0.0467t^{0.797}}$	2054
110	$R = 110 + (175 - 110)e^{-0.0579t^{0.706}}$	2045
105	$R = 105 + (175 - 105)e^{-0.0641t^{0.650}}$	2041
100	$R = 100 + (175 - 100)e^{-0.0673t^{0.611}}$	2039
95	$R = 95 + (175 - 95)e^{-0.0686t^{0.582}}$	2037

Table 6

These results show a relationship between the lower bound, L , and the predicted date for the 2-hour marathon. The smaller the lower bound, the sooner we can expect a 2-hour marathon. This finding coincides with common sense.

All the predictions in Table 6 for the 2-hour marathon seem rather cautious. If it happens much sooner, that may well be evidence that an even more sophisticated model is needed. It could even have happened between the time of writing this article and today, when you are reading it. 155

Finding the parameter values

Table 6 illustrates the versatility of the general exponential model. However, it does not address the question of how you determine the values of the various parameters.

One possible method would be to take a 4th point on the curve, giving 4 equations in the 4 unknowns, U , L , k and α . Apart from the fact that the resulting equations would be very difficult to solve, there is another point to be considered. 160

The curve in Fig. 3 was drawn by eye and so is not a curve of best fit in a mathematical sense. That would require a statistical technique like that used for the straight line in Fig. 1. This technique is built into curve-fitting software that will find the parameters in the equations of many curves of best fit. Such standard software would work for the simple exponential model but cannot handle the more complicated equation for the general exponential model. So special programming would be needed. 165

However, the success of such a statistical method depends on the quality of the data. While all the points in Fig. 3 correspond to the records given in Appendix B, and so are correct, they nonetheless all represent unusual occurrences; that is the nature of world records. Some experts believe that, for any athletics event, a better picture is obtained by taking, say, the best five performances each year and constructing a model based on them, rather than relying solely on rare and exceptional occurrences. 170

Attempts have been made to use such an approach to link sudden large improvements in athletics records to the possible use of performance-enhancing drugs, but so far this work has been inconclusive. 175

Appendix A Mile records from 1915 (men)

Year	Athlete	Nationality	Time
1915	Taber	USA	4 m 12.6 s
1923	Nurmi	Finland	4 m 10.4 s
1931	Ladoumegue	France	4 m 9.2 s
1933	Lovelock	New Zealand	4 m 7.6 s
1934	Cunningham	USA	4 m 6.8 s
1937	Wooderson	UK	4 m 6.4 s
1942	Hagg	Sweden	4 m 6.2 s
1942	Hagg	Sweden	4 m 4.6 s
1943	Andersson	Sweden	4 m 2.6 s
1944	Andersson	Sweden	4 m 1.6 s
1945	Hagg	Sweden	4 m 1.4 s
1954	Bannister	UK	3 m 59.4 s
1954	Landy	Australia	3 m 58.0 s
1957	Ibbotson	UK	3 m 57.2 s
1958	Elliot	Australia	3 m 54.5 s
1962	Snell	New Zealand	3 m 54.4 s
1964	Snell	New Zealand	3 m 54.1 s
1965	Jazy	France	3 m 53.6 s
1966	Ryun	USA	3 m 51.3 s
1967	Ryun	USA	3 m 51.1 s
1975	Bayi	Tanzania	3 m 51.0 s
1975	Walker	New Zealand	3 m 49.4 s
1979	Coe	UK	3 m 49.0 s
1980	Ovett	UK	3 m 48.8 s
1981	Coe	UK	3 m 48.53 s
1981	Ovett	UK	3 m 48.40 s
1981	Coe	UK	3 m 47.33 s
1985	Cram	UK	3 m 46.32 s
1993	Morceli	Algeria	3 m 44.39 s
1999	El Guerrouj	Morocco	3 m 43.13 s

Appendix B Marathon records (men)

Year	Athlete	Nationality	Time
1908	Hayes	USA	2 h 55 m 18 s
1909	Fowler	USA	2 h 52 m 45 s
1909	Clark	USA	2 h 46 m 52 s
1909	Raines	USA	2 h 46 m 04 s
1909	Barrett	UK	2 h 42 m 31 s
1909	Johansson	Sweden	2 h 40 m 34 s
1913	Green	UK	2 h 38 m 16 s
1913	Ahlgren	Sweden	2 h 36 m 06 s
1922	Kolehmainen	Finland	2 h 32 m 35 s
1925	Michelsen	USA	2 h 29 m 01 s
1935	Suzuki	Japan	2 h 27 m 49 s
1935	Ikenana	Japan	2 h 26 m 44 s
1935	Son	Korea	2 h 26 m 42 s
1947	Suh	Korea	2 h 25 m 39 s
1952	Peters	UK	2 h 20 m 42 s
1953	Peters	UK	2 h 18 m 40 s
1953	Peters	UK	2 h 18 m 34 s
1954	Peters	UK	2 h 17 m 39 s
1958	Popov	USSR	2 h 15 m 17 s
1960	Bikila	Ethiopia	2 h 15 m 16 s
1963	Teresawa	Japan	2 h 15 m 15 s
1963	Edelen	USA	2 h 14 m 28 s
1964	Heatley	UK	2 h 13 m 55 s
1964	Bikila	Ethiopia	2 h 12 m 11 s
1965	Shigematsu	Japan	2 h 12 m 00 s
1967	Clayton	Australia	2 h 09 m 36 s
1969	Clayton	Australia	2 h 08 m 33 s
1981	de Castella	Australia	2 h 08 m 18 s
1984	Jones	UK	2 h 08 m 05 s
1985	Lopes	Portugal	2 h 07 m 12 s
1988	Dinsamo	Ethiopia	2 h 06 m 50 s
1998	de Costa	Brazil	2 h 06 m 05 s
1999	Khannouchi	Morocco	2 h 05 m 42 s
2002	Khannouchi	USA	2 h 05 m 38 s
2003	Tergat	Kenya	2 h 04 m 55 s

**ADVANCED GCE UNIT
MATHEMATICS (MEI)**

Applications of Advanced Mathematics (C4)
Paper B: Comprehension

INSERT

TUESDAY 23 JANUARY 2007

4754(B)/01

Afternoon
Time: Up to 1 hour

INSTRUCTIONS TO CANDIDATES

- This insert contains the text for use with the questions.

Benford's Law

Leading digits

This article is concerned with a surprising property of the leading digits of numbers in various sets. The leading digit of a number is the first digit you read. In the number 193 000 the leading digit is 1. When a number is written in standard form, such as 1.93×10^5 or 2.78×10^{-7} , the leading digit is the digit before the decimal point, in these examples 1 and 2 respectively.

5

Mathematical sequences

Table 1 shows the integer powers of 2, from 2^1 to 2^{50} . In this table, which digits occur more frequently as the leading digit? You might expect approximately one ninth of the numbers to have a leading digit of 1, one ninth of the numbers to have a leading digit of 2, and so on. In fact, this is far from the truth.

10

2	2 048	2 097 152	2 147 483 648	2 199 023 255 552
4	4 096	4 194 304	4 294 967 296	4 398 046 511 104
8	8 192	8 388 608	8 589 934 592	8 796 093 022 208
16	16 384	16 777 216	17 179 869 184	17 592 186 044 416
32	32 768	33 554 432	34 359 738 368	35 184 372 088 832
64	65 536	67 108 864	68 719 476 736	70 368 744 177 664
128	131 072	134 217 728	137 438 953 472	140 737 488 355 328
256	262 144	268 435 456	274 877 906 944	281 474 976 710 656
512	524 288	536 870 912	549 755 813 888	562 949 953 421 312
1 024	1 048 576	1 073 741 824	1 099 511 627 776	1 125 899 906 842 624

Table 1

The frequencies of the different leading digits in these powers of 2 are shown in Table 2.

Leading digit	1	2	3	4	5	6	7	8	9
Frequency	15	10	5	5	5	4	1	5	0

Table 2

You can see that, for these data, 1 and 2 appear more frequently than any other numbers as the leading digit. Is this just a peculiarity of the first fifty powers of 2, or is a general pattern emerging?

15

Here is another example. Imagine you invest £100 in an account that pays compound interest at a rate of 20% per year. Table 3 shows the total amount (in £), after interest is added, at the end of each of the following 50 years.

3

120.00	743.01	4 600.51	28 485.16	176 372.59
144.00	891.61	5 520.61	34 182.19	211 647.11
172.80	1 069.93	6 624.74	41 018.63	253 976.53
207.36	1 283.92	7 949.68	49 222.35	304 771.83
248.83	1 540.70	9 539.62	59 066.82	365 726.20
298.60	1 848.84	11 447.55	70 880.19	438 871.44
358.32	2 218.61	13 737.06	85 056.22	526 645.73
429.98	2 662.33	16 484.47	102 067.47	631 974.87
515.98	3 194.80	19 781.36	122 480.96	758 369.85
619.17	3 833.76	23 737.63	146 977.16	910 043.82

Table 3

The frequencies of leading digits for these data are shown in Table 4.

Leading digit	1	2	3	4	5	6	7	8	9
Frequency	15	9	6	5	4	3	4	2	2

Table 4

The pattern that emerges is much the same as that in Table 2, with 1 appearing as the leading digit in 30% of cases and 2 appearing in 18% of cases.

20

Now imagine that a second person invests £200 rather than £100. Each amount in this person's table (Table 5) is double the corresponding amount in Table 3.

240.00	1 486.02	9 201.02	56 970.32	352 745.18
288.00	1 783.22	11 041.23	68 364.38	423 294.21
345.60	2 139.86	13 249.47	82 037.25	507 953.05
414.72	2 567.84	15 899.37	98 444.70	609 543.66
497.66	3 081.40	19 079.24	118 133.65	731 452.40
597.20	3 697.69	22 895.09	141 760.37	877 742.88
716.64	4 437.22	27 474.11	170 112.45	1 053 291.45
859.96	5 324.67	32 968.93	204 134.94	1 263 949.74
1 031.96	6 389.60	39 562.72	244 961.93	1 516 739.69
1 238.35	7 667.52	47 475.26	293 954.31	1 820 087.63

Table 5

The frequencies of leading digits for these data are shown in Table 6.

Leading digit	1	2	3	4	5	6	7	8	9
Frequency	15	9	6	5	4	3	3	3	2

Table 6

A remarkable result now emerges. The frequencies in Table 6 are almost the same as those in Table 4.

25

In Table 3 there are 15 numbers with a leading digit of 1. Each of these numbers, when doubled, has a leading digit of either 2 or 3, as can be seen in Table 5. Similarly, the numbers in Table 3 with leading digit 5, 6, 7, 8 or 9 give numbers in Table 5 with leading digit 1. These outcomes are reflected in the frequencies in Table 4 and Table 6.

30

Physical phenomena

The numbers in Tables 1, 3 and 5 were all generated mathematically. Now look at something less mathematical in origin.

The frequencies of the leading digits of the areas of the world's 100 largest countries, measured in square kilometres, are given in Table 7. (For interest the data are given in Appendix A.)

35

Leading digit	1	2	3	4	5	6	7	8	9
Frequency	33	20	13	8	6	6	4	4	6

Table 7

You will notice that these data, even though they have a non-mathematical origin, show essentially the same pattern of frequencies. The populations of cities and countries also show this general pattern. As further examples, if you take the heights of the world's tallest mountains, the lengths of Europe's longest rivers, the numbers of votes cast for each political party in every constituency in a general election or the values of a wide range of scientific constants, you will find a similar pattern in many cases. The remainder of this article looks at such physical data, rather than mathematically generated data, and answers the following question.

40

Why does this pattern in leading digits occur, and how can it be modelled mathematically?

Benford's Law

This phenomenon was noted in 1881 by Simon Newcombe, an American mathematician and astronomer, and then rediscovered by the physicist Frank Benford in 1938. Benford analysed 20 229 sets of data, including information about rivers, baseball statistics and all the numbers in an issue of *Reader's Digest*. He was rewarded for his efforts by having the law named after him.

45

Benford's Law gives a formula for the proportions of leading digits in data sets like these. This formula will be derived over the next few pages.

50

The proportions given by Benford's Law are illustrated in Fig. 8.

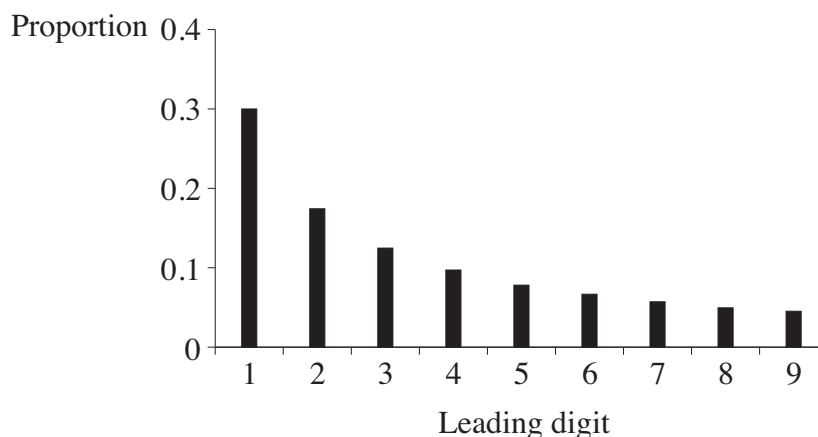

Fig. 8

This shows that, in a typical large data set, approximately 30% of the data values have leading digit 1 but fewer than 5% have leading digit 9. For small data sets, you cannot expect the leading digits to follow Benford's Law closely; the larger the data set, the better the fit is likely to be.

55

Fig. 9 shows the proportions for the leading digits of the areas of the world's largest countries, derived from Table 7, together with the proportions given by Benford's Law. You will see that there is a very good match.

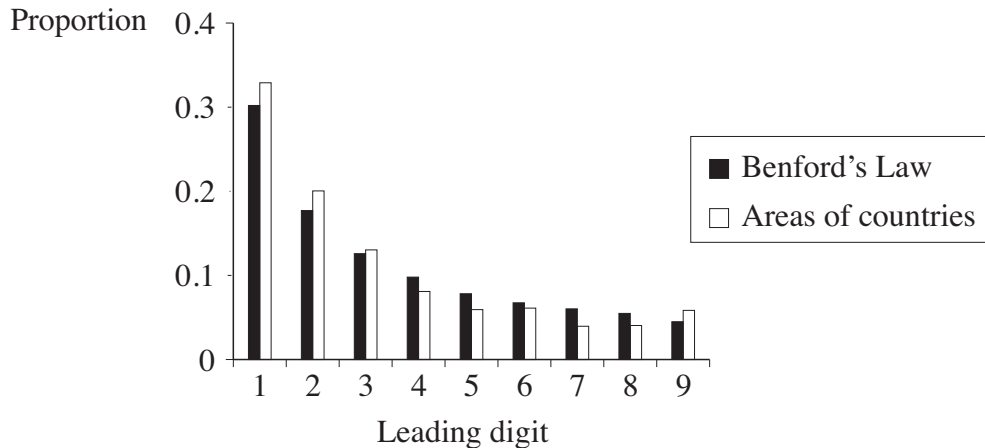

Fig. 9

Benford's Law does not apply to all situations, even when there is a large data set. There is still debate about the conditions under which it applies. The rest of this article relates to situations in which it does apply.

60

Scale invariance

If the areas of the countries in Appendix A are measured in square miles, rather than square kilometres, it turns out that the leading digits still follow the same pattern. This is a feature of all data sets which follow Benford's Law; it does not matter what units are used when measuring the data. The next example illustrates this.

65

Table 10 shows the frequencies of the leading digits of the share prices of the 100 largest UK companies on 28 February 2006, in pounds sterling, US dollars and euros.

Leading digit	1	2	3	4	5	6	7	8	9
Frequency (£)	33	14	7	4	14	11	3	8	6
Frequency (\$)	41	18	13	6	6	2	3	7	4
Frequency (€)	36	18	10	8	2	4	8	8	6

Table 10

These results are illustrated in Fig. 11 along with the proportions given by Benford's Law. Despite there being only 100 items of data, two features are evident.

70

- There is a reasonable agreement between the proportions for the three currencies.
- Benford's Law gives a reasonable approximation in each case.

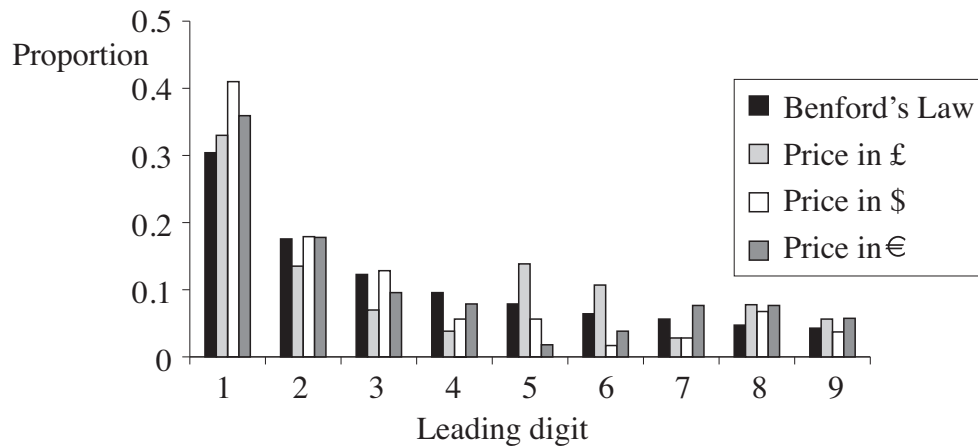

Fig. 11

This property, that it does not matter what units are used when measuring the data, is called *scale invariance*.

75

The frequencies of leading digits

The idea of scale invariance is important. If scale invariance applies, what does this tell us about the frequencies of leading digits?

In order to answer this question it is helpful to use the following notation.

- p_n represents the proportion of data values with leading digit n .

80

Thus p_1 represents the proportion of data values with leading digit 1, p_2 represents the proportion of data values with leading digit 2, and so on. Clearly $\sum_{n=1}^9 p_n = 1$.

The proportions p_1, p_2, \dots, p_9 can be represented by the areas of the rectangles on a diagram such as Fig. 12. The total area is 1.

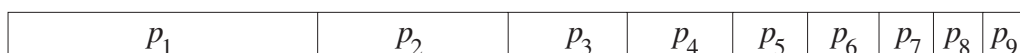

Fig. 12

Many things can be deduced about the values of p_1, p_2, \dots, p_9 by thinking about a large data set in which scale invariance holds exactly. Here are some of them.

85

- If every number in the data set is multiplied by 2, then all the numbers with leading digit 1, and no others, are mapped to numbers with leading digit either 2 or 3. Since this does not change the distribution of leading digits, it follows that

$$p_1 = p_2 + p_3.$$

90

- Similarly, when multiplying by 2, all numbers with leading digit 5, 6, 7, 8 or 9, and no others, are mapped to numbers with leading digit 1. Therefore

$$p_5 + p_6 + p_7 + p_8 + p_9 = p_1.$$

As a consequence of these two results,

$$p_1 + (p_2 + p_3) + p_4 + (p_5 + p_6 + p_7 + p_8 + p_9) = 3p_1 + p_4, \quad 95$$

from which it follows that

$$3p_1 + p_4 = 1$$

and so $p_1 < \frac{1}{3}$.

- By using a multiplier of 4, instead of 2, it follows that

$$p_1 = p_4 + p_5 + p_6 + p_7. \quad 100$$

This shows that $p_1 > p_4$. Using the fact that $3p_1 + p_4 = 1$, it follows that $p_1 > \frac{1}{4}$. Therefore $\frac{1}{4} < p_1 < \frac{1}{3}$. This is consistent with the value of about 0.3 observed in several of the data sets considered earlier in the article.

In a similar way, other relationships connecting values of p_n , such as $p_1 = p_3 + p_4 + p_5$, $p_6 + p_7 = p_3$ and $p_2 = p_6 + p_7 + p_8$, can be derived. 105

Deriving Benford's Law

It is helpful now to introduce the quantities $L(1), L(2), \dots, L(10)$, defined as follows.

- $L(1) = 0$
 - $L(2) = p_1$
 - $L(3) = p_1 + p_2$
 - $L(4) = p_1 + p_2 + p_3$
 - ...
 - $L(10) = p_1 + p_2 + \dots + p_9 = 1$
- 110

The quantities $L(1), L(2), \dots, L(10)$ are the cumulative proportions. They are illustrated in Fig. 13. 115

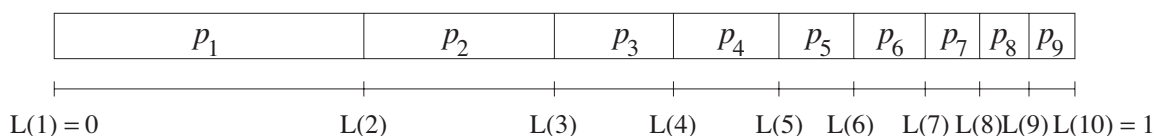

Fig. 13

What can you say about the quantities $L(1), L(2), \dots, L(10)$?

- You know $p_1 = p_2 + p_3$.

This corresponds to $L(2) - L(1) = L(4) - L(2)$ which simplifies to $L(4) = 2 \times L(2)$.

- Similarly $p_1 = p_3 + p_4 + p_5$.

This corresponds to $L(2) - L(1) = L(6) - L(3)$ which simplifies to $L(6) = L(3) + L(2)$. 120

- Also $p_6 + p_7 = p_3$.

This corresponds to $L(8) - L(6) = L(4) - L(3)$. Combining this with the last two results gives $L(8) = 3 \times L(2)$.

These results, and others like them, suggest that $L(n)$ is a logarithmic function. The fact that $L(10) = 1$ shows that the base of the logarithms is 10, and so $L(n) = \log_{10} n$. 125

It follows that $p_n = L(n+1) - L(n) = \log_{10}(n+1) - \log_{10} n$. That is, the proportion of data values with leading digit n (where $1 \leq n \leq 9$) is $\log_{10}(n+1) - \log_{10} n$. This is Benford's Law.

Uses of Benford's Law

Since the 1980s Benford's Law has, on several occasions, been used successfully to convict people accused of fraud. When concocting figures to include in fictitious company accounts, it is natural to try to make the amounts look 'random' or 'average'. This might, for example, be done by including a high proportion of 'average' amounts beginning with 'middle digits' such as 4, 5 or 6, or including amounts just under £1000, £10 000 and £100 000, in an attempt to avoid closer analysis. In this way fraudsters are generating data which do not follow Benford's Law and thereby attracting the kind of scrutiny they were trying to avoid. 135

Appendix A Areas of countries (thousands of km²)

Russia	17 075	Pakistan	804	Poland	313
Canada	9976	Mozambique	802	Italy	301
USA	9629	Turkey	781	Philippines	300
China	9597	Chile	757	Ecuador	284
Brazil	8512	Zambia	753	Burkina Faso	274
Australia	7687	Myanmar	679	New Zealand	269
India	3288	Afghanistan	648	Gabon	268
Argentina	2767	Somalia	638	Western Sahara	266
Kazakhstan	2717	C. African Republic	623	Guinea	246
Sudan	2506	Ukraine	604	Great Britain	
Algeria	2382	Botswana	600	(and N Ireland)	245
Congo (Dem. Rep.)	2345	Madagascar	587	Ghana	239
Greenland	2166	Kenya	583	Romania	238
Mexico	1973	France	547	Laos	237
Saudi Arabia	1961	Yemen	528	Uganda	236
Indonesia	1919	Thailand	514	Guyana	215
Libya	1760	Spain	505	Oman	212
Iran	1648	Turkmenistan	488	Belarus	208
Mongolia	1565	Cameroon	475	Kyrgyzstan	199
Peru	1285	Papua New Guinea	463	Senegal	196
Chad	1284	Sweden	450	Syria	185
Niger	1267	Uzbekistan	447	Cambodia	181
Angola	1247	Morocco	447	Uruguay	176
Mali	1240	Iraq	437	Tunisia	164
South Africa	1220	Paraguay	407	Suriname	163
Colombia	1139	Zimbabwe	391	Bangladesh	144
Ethiopia	1127	Japan	378	Tajikistan	143
Bolivia	1099	Germany	357	Nepal	141
Mauritania	1031	Congo (Rep.)	342	Greece	132
Egypt	1001	Finland	337	Nicaragua	129
Tanzania	945	Malaysia	330	Eritrea	121
Nigeria	924	Vietnam	330	Korea (North)	121
Venezuela	912	Norway	324	Malawi	118
Namibia	825	Cote d'Ivoire	322		

**ADVANCED GCE UNIT
 MATHEMATICS (MEI)**

Applications of Advanced Mathematics (C4)

Paper B: Comprehension

TUESDAY 23 JANUARY 2007

4754(B)/01

Afternoon
 Time: Up to 1 hour

Additional materials:
 Rough paper
 MEI Examination Formulae and Tables (MF2)

Candidate
 Name

Centre
 Number

--	--	--	--	--

Candidate
 Number

--	--	--	--

INSTRUCTIONS TO CANDIDATES

- Write your name, centre number and candidate number in the spaces provided.
- Answer **all** the questions.
- Write your answers in the spaces provided on the question paper.
- You are permitted to use a graphical calculator in this paper.
- Final answers should be given to a degree of accuracy appropriate to the context.

INFORMATION FOR CANDIDATES

- The number of marks is given in brackets [] at the end of each question or part question.
- The total number of marks for this paper is 18.
- The insert contains the text for use with the questions.
- You may find it helpful to make notes and do some calculations as you read the passage.
- You are **not** required to hand in these notes with the question paper.

ADVICE TO CANDIDATES

- Read each question carefully and make sure you know what you have to do before starting your answer.
- You are advised that an answer may receive **no marks** unless you show sufficient detail of the working to indicate that a correct method is being used.

For Examiner's Use	
Qu.	Mark
1	
2	
3	
4	
5	
6	
Total	

This document consists of **4** printed pages and an insert.

1 In a certain country, twenty cars are on display in a car showroom. The costs of the cars in the local currency, the zen, are shown below.

10 255	23 250	48 500	25 950	12 340
34 750	5 690	13 580	7 450	9 475
18 890	14 675	6 295	21 225	37 850
51 200	43 340	16 575	8 380	28 880

(i) Complete the table giving the frequencies of the leading digits. [1]

Leading digit	1	2	3	4	5	6	7	8	9
Frequency	6	4	2						

The country joins the European Union and so the costs of the cars are converted to euros. The exchange rate is 1 zen = 3 euros.

(ii) Give the costs of the cars in euros in the space below and then complete the table giving the frequencies of the leading digits in euros. [2]

.....

.....

.....

.....

Leading digit	1	2	3	4	5	6	7	8	9
Frequency	7								0

(iii) In the table below, give the frequencies predicted by Benford's Law, in each case correct to **one decimal place**. [2]

Leading digit	1	2	3	4	5	6	7	8	9
Frequency	6.0								

(iv) Compare the results in the three tables. [1]

.....

.....

- 2 On lines 28 and 29 it says ‘Similarly, the numbers in Table 3 with leading digit 5, 6, 7, 8 or 9 give numbers in Table 5 with leading digit 1’. Explain how this is reflected in the frequencies in Table 4 and Table 6. [1]

.....

.....

.....

- 3 Line 104 refers to the relationship $p_1 = p_3 + p_4 + p_5$. Explain how this relationship is obtained. [2]

.....

.....

.....

.....

- 4 Benford’s Law is quoted on lines 126 to 127. Show that this is equivalent to

$$p_n = \log_{10}\left(1 + \frac{1}{n}\right).$$

[2]

.....

.....

.....

.....

- 5 Using the results $L(4) = 2 \times L(2)$ and $L(6) = L(3) + L(2)$, and the relationship $p_6 + p_7 = p_3$, derive the result $L(8) = 3 \times L(2)$ stated on line 123. [3]

.....

.....

.....

.....

.....

.....

- 6 The distribution of leading digits in the **daily** wages, in pounds sterling, of the employees of a firm is given in the table below.

Leading digit	1	2	3	4	5	6	7	8	9
Frequency (daily wages)	29	16	12	10	8	7	6	5	4

The employees all work a 5-day week. Using the values for the **daily** wages above, find the entries marked a and b for the **weekly** wages in the table below. Explain your reasoning.[4]

Leading digit	1	2	3	4	5	6	7	8	9
Frequency (weekly wages)	a			b					

.....

.....

.....

.....

.....

.....

.....

.....

**ADVANCED GCE UNIT
 MATHEMATICS (MEI)**

Applications of Advanced Mathematics (C4)

Paper B: Comprehension

THURSDAY 14 JUNE 2007

4754(B)/01

Afternoon
 Time: Up to 1 hour

Additional materials:
 Rough paper
 MEI Examination Formulae and Tables (MF2)

Candidate
 Name

Centre
 Number

--	--	--	--	--

Candidate
 Number

--	--	--	--

INSTRUCTIONS TO CANDIDATES

- Write your name, centre number and candidate number in the spaces above.
- Answer **all** the questions.
- Write your answers in the spaces provided on the question paper.
- You are permitted to use a graphical calculator in this paper.
- Final answers should be given to a degree of accuracy appropriate to the context.

INFORMATION FOR CANDIDATES

- The number of marks is given in brackets [] at the end of each question or part question.
- The total number of marks for this paper is 18.
- The insert contains the text for use with the questions.
- You may find it helpful to make notes and do some calculations as you read the passage.
- You are **not** required to hand in these notes with the question paper.

ADVICE TO CANDIDATES

- Read each question carefully and make sure you know what you have to do before starting your answer.
- You are advised that an answer may receive **no marks** unless you show sufficient detail of the working to indicate that a correct method is being used.

For Examiner's Use	
Qu.	Mark
1	
2	
3	
4	
5	
Total	

This document consists of **5** printed pages, **3** blank pages and an insert.

1 This basic cycloid has parametric equations

$$x = a\theta - a \sin \theta, \quad y = a - a \cos \theta.$$

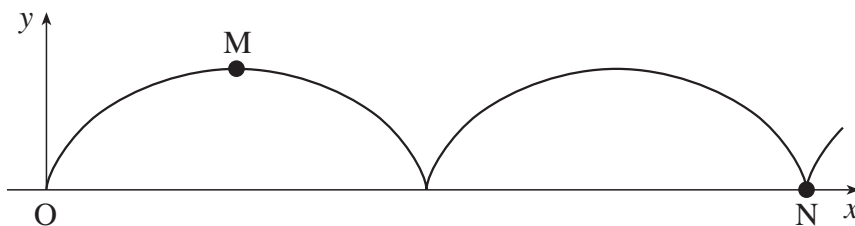

Find the coordinates of the points M and N, stating the value of θ at each of them. [2]

Point M

Point N

2 A sea wave has parametric equations (in suitable units)

$$x = 7\theta - 0.25 \sin \theta, \quad y = 0.25 \cos \theta.$$

Find the wavelength and height of the wave. [3]

.....

.....

.....

3 The graph below shows the profile of a wave.

(i) Assuming that it has parametric equations of the form given on line 68, find the values of a and b . [2]

(ii) Investigate whether the ratio of the trough length to the crest length is consistent with this shape. [3]

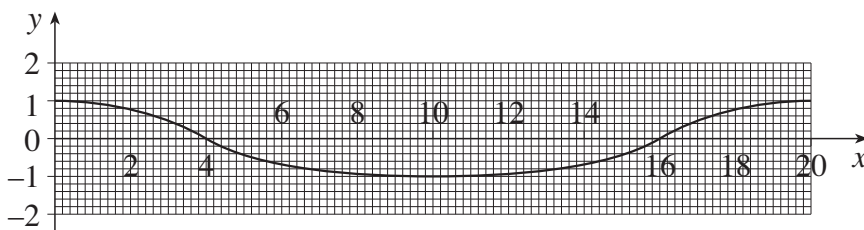

(i)

.....

(ii)

.....

.....

.....

- 4 This diagram illustrates two wave shapes U and V . They have the same wavelength and the same height.

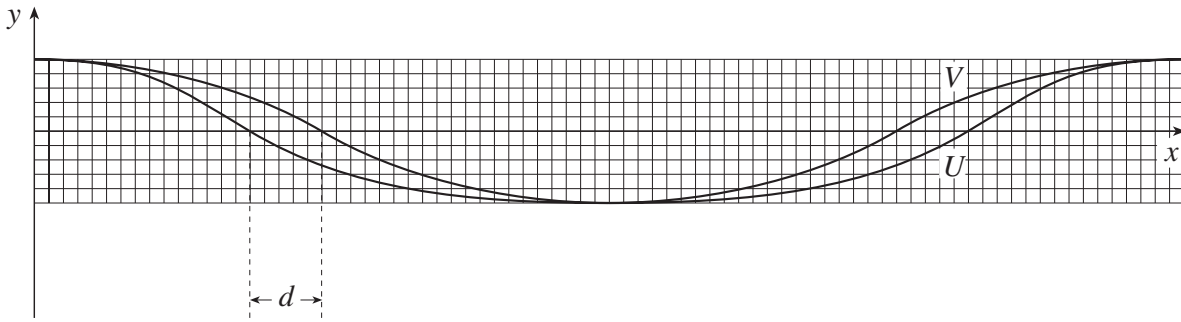

One of the curves is a sine wave, the other is a curtate cycloid.

- (i) State which is which, justifying your answer. [1]

(i)

The parametric equations for the curves are:

$$x = a\theta, \quad y = b \cos \theta,$$

and
$$x = a\theta - b \sin \theta, \quad y = b \cos \theta.$$

- (ii) Show that the distance marked d on the diagram is equal to b . [2]

- (iii) Hence justify the statement in lines 109 to 111: “In such cases, the curtate cycloid and the sine curve with the same wavelength and height are very similar and so the sine curve is also a good model.” [2]

(ii)

(iii)

- 5 The diagram shows a curtate cycloid with scales given. Show that this curve could not be a scale drawing of the shape of a stable sea wave. [3]

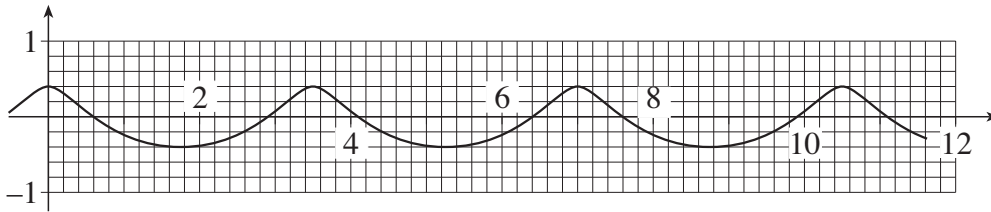

.....

.....

.....

.....

**ADVANCED GCE UNIT
MATHEMATICS (MEI)**

Applications of Advanced Mathematics (C4)

Paper B: Comprehension

INSERT

THURSDAY 14 JUNE 2007

4754(B)/01

Afternoon
Time: Up to 1 hour

INSTRUCTIONS TO CANDIDATES

- This insert contains the text for use with the questions.

This document consists of **8** printed pages.

Modelling sea waves

Introduction

There are many situations in which waves and oscillations occur in nature and often they are accurately modelled by the sine curve. However, this is not the case for sea waves as these come in a variety of shapes. The photograph in Fig. 1 shows an extreme form of sea wave being ridden by a surfer.

5



Fig. 1

At any time many parts of the world's oceans are experiencing storms. The strong winds create irregular *wind waves*. However, once a storm has passed, the waves form into a regular pattern, called *swell*. Swell waves are very stable; those resulting from a big storm would travel several times round the earth if they were not stopped by the land.

10

Fig. 2 illustrates a typical swell wave, but with the vertical scale exaggerated. The horizontal distance between successive *peaks* is the *wavelength*; the vertical distance from the lowest point in a *trough* to a peak is called the *height*. The height is twice the *amplitude* which is measured from the horizontal *line of mid-height*. The upper part is the *crest*. These terms are illustrated in Fig. 2.

15

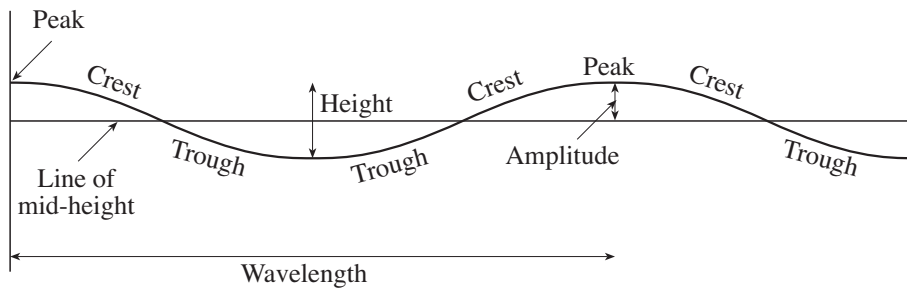

Fig. 2

The speed of a wave depends on the depth of the water; the deeper the water, the faster the wave. (This is, however, not true for very deep water, where the wave speed is independent of the depth.) This has a number of consequences for waves as they come into shallow water.

- Their speed decreases.
- Their wavelength shortens.
- Their height increases.

20

Observations show that, as their height increases, the waves become less symmetrical. The troughs become relatively long and the crests short and more pointed.

The profile of a wave approaching land is illustrated in Fig. 3. Eventually the top curls over and the wave “breaks”.

25



Fig. 3

If you stand at the edge of the sea you will see the water from each wave running up the shore towards you. You might think that this water had just travelled across the ocean. That would be wrong. When a wave travels across deep water, it is the shape that moves across the surface and not the water itself. It is only when the wave finally reaches land that the actual water moves any significant distance.

30

Experiments in wave tanks have shown that, except near the shore, each drop of water near the surface undergoes circular motion (or very nearly so). This has led people to investigate the possibility that a form of cycloid would provide a better model than a sine curve for a sea wave.

Cycloids

There are several types of cycloid. In this article, the name *cycloid* refers to one of the family of curves which form the locus of a point on a circle rolling along a straight horizontal path.

35

Fig. 4 illustrates the basic cycloid; in this case the point is on the circumference of the circle.

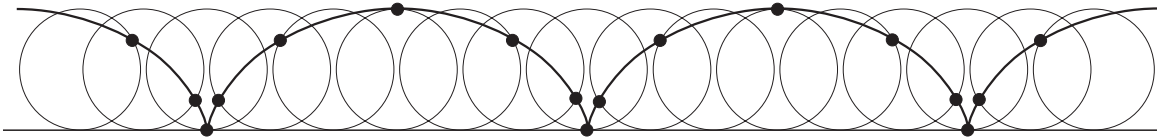

Fig. 4

Two variations on this basic cycloid are the prolate cycloid, illustrated in Fig. 5, and the curtate cycloid illustrated in Fig. 6. The prolate cycloid is the locus of a point attached to the circle but outside the circumference (like a point on the flange of a railway train's wheel); the curtate cycloid is the locus of a point inside the circumference of the circle.

40

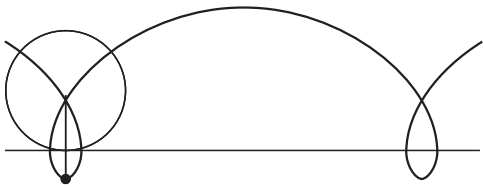

Fig. 5

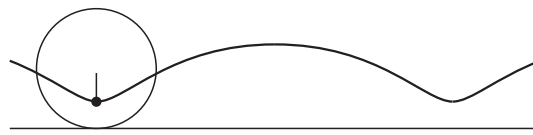

Fig. 6

When several cycles of the curtate cycloid are drawn “upside down”, as in Fig. 7, the curve does indeed look like the profile of a wave in shallow water.



Fig. 7

The equation of a cycloid

The equation of a cycloid is usually given in parametric form.

45

Fig. 8.1 and Fig. 8.2 illustrate a circle rolling along the x -axis. The circle has centre Q and radius a . P and R are points on its circumference and angle $PQR = \theta$, measured in radians. Fig. 8.1 shows the initial position of the circle with P at its lowest point; this is the same point as the origin, O . Some time later the circle has rolled to the position shown in Fig. 8.2 with R at its lowest point.

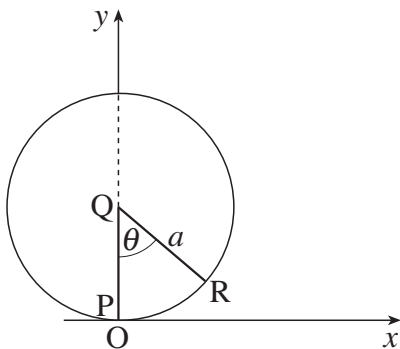

Fig. 8.1

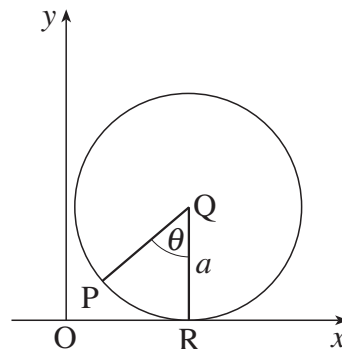

Fig. 8.2

In travelling to its new position, the circle has rolled the distance OR in Fig. 8.2. Since it has rolled along its circumference, this distance is the same as the arc length PR, and so is $a\theta$. Thus the coordinates of the centre, Q, in Fig. 8.2 are $(a\theta, a)$. To find the coordinates of the point P in Fig. 8.2, look at triangle QPZ in Fig. 9.

50

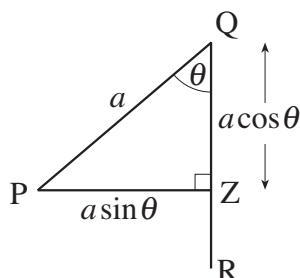

Fig. 9

You can see that

$$PZ = a \sin \theta \quad \text{and} \quad QZ = a \cos \theta.$$

55

Hence the coordinates of P are $(a\theta - a \sin \theta, a - a \cos \theta)$, and so the locus of the point P is described by the curve with parametric equations

$$x = a\theta - a \sin \theta, \quad y = a - a \cos \theta.$$

This is the basic cycloid.

These parametric equations can be generalised to

60

$$x = a\theta - b \sin \theta, \quad y = a - b \cos \theta,$$

where b is the distance of the moving point from the centre of the circle.

For $b < a$ the curve is a *curtate cycloid*,
 $b = a$ the curve is a *basic cycloid*,
 $b > a$ the curve is a *prolate cycloid*.

65

The equivalent equations with the curve turned “upside down”, and with the mid-height of the curve now on the x -axis, are

$$x = a\theta - b \sin \theta, \quad y = b \cos \theta.$$

(Notice that positive values of y are still measured vertically upwards.)

Modelling a particular wave

70

A question that now arises is how to fit an equation to a particular wave profile.

If you assume that the wave is a cycloid, there are two parameters to be found, a and b .

Since $y = b \cos \theta$,

- the maximum value of y is b and this occurs when $\theta = 0, 2\pi, 4\pi, \dots$,
- the minimum value of y is $-b$ and this occurs when $\theta = \pi, 3\pi, 5\pi, \dots$,
- the height of the wave is $2b$.

75

The wavelength is the horizontal distance between successive maximum values of y .

- A maximum occurs when $\theta = 0$ and $x = 0$.
- The next maximum occurs when $\theta = 2\pi$ and in that case $x = a \times (2\pi) - b \times \sin(2\pi) = 2\pi a$.
- The wavelength is $2\pi a$.

80

Thus if a wave has a cycloid form, $a = \frac{\text{wavelength}}{2\pi}$ and $b = \frac{\text{height}}{2}$.

The profile of a possible wave shape is illustrated in Fig. 10. You can see that the wavelength is 16 units and the height is 2 units. So if it is a cycloid shape, the values of a and b would be 2.54... and 1; it is actually easier to work with πa , which would have the value 8 in this case.

85

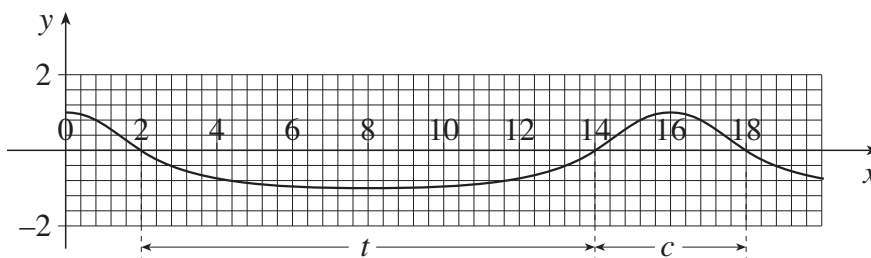

Fig. 10

However, finding values for a and b does not in itself show that the form of a wave is indeed a cycloid. One way of checking whether this could be a good model is to measure the length of the trough of the wave (the distance for which it is below mid-height, and so $y < 0$) and the length of its crest (the distance for which it is above mid-height, and so $y > 0$.) These distances are marked as t and c in Fig. 10.

90

The ratio of the measured distances t and c is then compared with the equivalent ratio for a cycloid.

In Fig. 10, $t = 12$ and $c = 4$, so the ratio $t:c$ is 3:1.

To find the equivalent ratio for a cycloid, start by finding the values of θ for which the wave is at mid-height.

95

When $y = 0$, the values of θ are $\frac{\pi}{2}, \frac{3\pi}{2}, \frac{5\pi}{2}, \dots$.

The corresponding values of x are $\left(\frac{\pi a}{2} - b\right)$, $\left(\frac{3\pi a}{2} + b\right)$, $\left(\frac{5\pi a}{2} - b\right)$, ...

So

$$t = \left(\frac{3\pi a}{2} + b\right) - \left(\frac{\pi a}{2} - b\right) = \pi a + 2b,$$

$$c = \left(\frac{5\pi a}{2} - b\right) - \left(\frac{3\pi a}{2} + b\right) = \pi a - 2b,$$

and the ratio $t : c$ is $(\pi a + 2b) : (\pi a - 2b)$.

100

Using $\pi a = 8$ and $b = 1$, the values of t and c would be 10 and 6 and the ratio $t : c$ would be 10 : 6 or 1.67 : 1.

As this ratio is quite different from 3 : 1, the curve in Fig. 10 is not a cycloid. In this case, the troughs are too long and the crests too short.

Sea waves

105

In fact, observations of real swell waves show that they are well modelled as curtate cycloids.

In the deep ocean, the wavelength may be hundreds of metres and the height less than 5 metres. This corresponds to a large value of a and a small value of b . For a wavelength of 200 metres and a height of 2 metres, the ratio of height to wavelength is 1 : 100. In such cases, the curtate cycloid and the sine curve with the same wavelength and height are very similar and so the sine curve is also a good model.

110

As the wave comes into shallower water, the ratio of height to wavelength increases. The curtate cycloid remains a good model but the sine curve becomes increasingly unsuitable.

During this phase the value of a decreases and the value of b increases. Thought of in terms of the locus of a point on a rolling circle, the point moves away from the centre while the radius decreases.

115

Eventually, however, the wave breaks with its top curling over. It is tempting to imagine that this would correspond to the case $b = a$, when the cycloid changes from curtate to prolate and develops a loop. That would correspond to a height to wavelength ratio of 1 : π . However, observation shows that breaking occurs well before that, when the height to wavelength ratio is about 1 : 7.

120

This observation is not surprising when you remember that the motion of the drops of water in a wave is circular. Such circular motion cannot occur at the sharp point at the peak of a basic cycloid. The wave becomes unstable when the circular motion can no longer be sustained within the wave. At this point the cycloid ceases to provide a model for sea waves.

125

Other sea waves

In addition to swell and wind waves, there are several other types of sea wave.

Internal waves are formed when a current runs over an uneven seabed. Because the currents are often caused by the tides, these waves are often called tidal rips. They often form off headlands, and can also take the form of whirlpools like the famous Corrievechan off the west of Scotland. 130

Tidal waves are caused by the combined gravitational pull of the moon and sun; they have a period of just over 12 hours and a wavelength of half the circumference of the earth. In mid-ocean their height is extremely small but in coastal waters it can be over 10 metres.

Tsunamis are caused by events such as earthquakes and volcanoes. Compared with swell, a tsunami has a very long wavelength, typically at least 100 kilometres. In mid-ocean their height is small and so they are not usually noticed by sailors. However, because of their long wavelength, they build up to a great height when they come into land and cause devastation to coastal areas. 135

The study of sea waves has been given a boost recently by satellite imaging. This allows the profiles of waves to be determined accurately. One discovery is that *very high waves* are much more common than had been expected. These giant waves are not well understood and it may well be that they require a new model.

**ADVANCED GCE
MATHEMATICS (MEI)**

4754/01A

Applications of Advanced Mathematics (C4) Paper A

TUESDAY 22 JANUARY 2008

Afternoon

Time: 1 hour 30 minutes

Additional materials: Answer Booklet (8 pages)
Graph paper
MEI Examination Formulae and Tables (MF2)

INSTRUCTIONS TO CANDIDATES

- Write your name in capital letters, your Centre Number and Candidate Number in the spaces provided on the Answer Booklet.
- Read each question carefully and make sure you know what you have to do before starting your answer.
- Answer **all** the questions.
- You are permitted to use a graphical calculator in this paper.
- Final answers should be given to a degree of accuracy appropriate to the context.

INFORMATION FOR CANDIDATES

- The number of marks is given in brackets [] at the end of each question or part question.
- The total number of marks for this paper is 72.
- You are advised that an answer may receive **no marks** unless you show sufficient detail of the working to indicate that a correct method is being used.

NOTE

- This paper will be followed by **Paper B: Comprehension**.

This document consists of 4 printed pages.

Section A (36 marks)

- 1 Express $3 \cos \theta + 4 \sin \theta$ in the form $R \cos(\theta - \alpha)$, where $R > 0$ and $0 < \alpha < \frac{1}{2}\pi$.

Hence solve the equation $3 \cos \theta + 4 \sin \theta = 2$ for $-\pi \leq \theta \leq \pi$. [7]

- 2 (i) Find the first three terms in the binomial expansion of $\frac{1}{\sqrt{1-2x}}$. State the set of values of x for which the expansion is valid. [5]

- (ii) Hence find the first three terms in the series expansion of $\frac{1+2x}{\sqrt{1-2x}}$. [3]

- 3 Fig. 3 shows part of the curve $y = 1 + x^2$, together with the line $y = 2$.

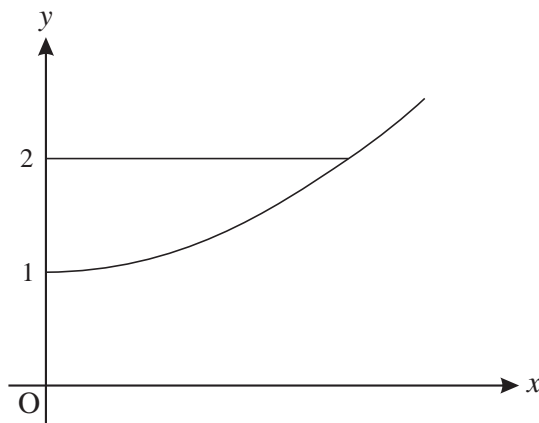

Fig. 3

The region enclosed by the curve, the y -axis and the line $y = 2$ is rotated through 360° about the y -axis. Find the volume of the solid generated, giving your answer in terms of π . [5]

- 4 The angle θ satisfies the equation $\sin(\theta + 45^\circ) = \cos \theta$.

- (i) Using the exact values of $\sin 45^\circ$ and $\cos 45^\circ$, show that $\tan \theta = \sqrt{2} - 1$. [5]

- (ii) Find the values of θ for $0^\circ < \theta < 360^\circ$. [2]

- 5 Express $\frac{4}{x(x^2 + 4)}$ in partial fractions. [6]

- 6 Solve the equation $\operatorname{cosec} \theta = 3$, for $0^\circ < \theta < 360^\circ$. [3]

Section B (36 marks)

- 7 A glass ornament OABCDEFG is a truncated pyramid on a rectangular base (see Fig. 7). All dimensions are in centimetres.

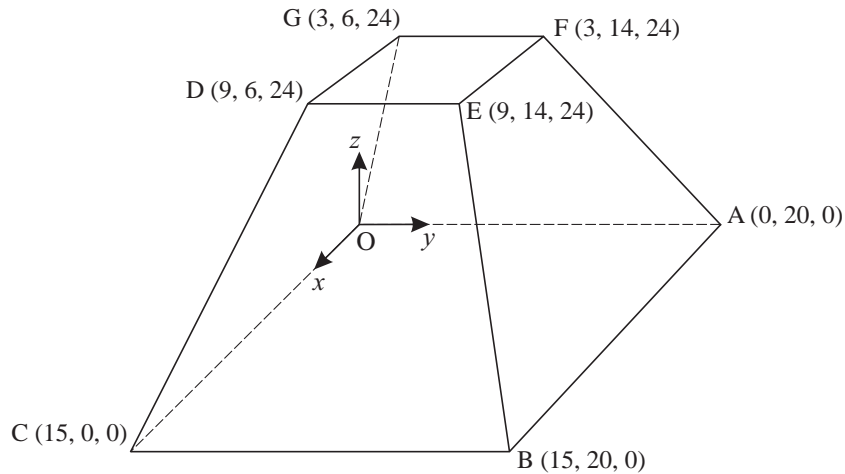

Fig. 7

- (i) Write down the vectors \overrightarrow{CD} and \overrightarrow{CB} . [2]
- (ii) Find the length of the edge CD. [2]
- (iii) Show that the vector $4\mathbf{i} + \mathbf{k}$ is perpendicular to the vectors \overrightarrow{CD} and \overrightarrow{CB} . Hence find the cartesian equation of the plane BCDE. [5]
- (iv) Write down vector equations for the lines OG and AF.

Show that they meet at the point P with coordinates (5, 10, 40). [5]

You may assume that the lines CD and BE also meet at the point P.

The volume of a pyramid is $\frac{1}{3} \times \text{area of base} \times \text{height}$.

- (v) Find the volumes of the pyramids POABC and PDEFG.

Hence find the volume of the ornament. [4]

**ADVANCED GCE
MATHEMATICS (MEI)**

4754/01B

Applications of Advanced Mathematics (C4) Paper B: Comprehension

TUESDAY 22 JANUARY 2008

Afternoon

Time: Up to 1 hour

Additional materials: Rough paper
MEI Examination Formulae and Tables (MF2)

Candidate
Forename

--	--	--	--	--	--	--	--	--	--

Candidate
Surname

--	--	--	--	--	--	--	--	--	--

Centre
Number

--	--	--	--	--	--

Candidate
Number

--	--	--	--	--

INSTRUCTIONS TO CANDIDATES

- Write your name in capital letters, your Centre Number and Candidate Number in the boxes above.
- Read each question carefully and make sure you know what you have to do before starting your answer.
- Answer **all** the questions.
- Write your answers in the spaces provided on the question paper.
- You are permitted to use a graphical calculator in this paper.
- Final answers should be given to a degree of accuracy appropriate to the context.

INFORMATION FOR CANDIDATES

- The number of marks is given in brackets [] at the end of each question or part question.
- The total number of marks for this paper is 18.
- The insert contains the text for use with the questions.
- You may find it helpful to make notes and do some calculations as you read the passage.
- You are **not** required to hand in these notes with your question paper.
- You are advised that an answer may receive **no marks** unless you show sufficient detail of the working to indicate that a correct method is being used.

FOR EXAMINER'S USE	
1	
2	
3	
4	
5	
6	
7	
TOTAL	

This document consists of **4** printed pages and an insert.

- 1 An additive sequence has third term 5 and fourth term 6. Complete the sequence up to its sixth term. [2]

____, _____, 5, 6, _____, _____.

.....

- 2 The Lucas sequence on line 32 is 2, 1, 3, 4, 7, 11, 18, 29,
 State, with reasoning, whether the hundredth term will be odd or even. [2]

.....

- 3 On lines 56 and 57 it is stated that the sequence $1, \phi, \phi^2, \phi^3, \phi^4, \phi^5, \dots$ can be written in the form $1, \phi, \phi + 1, 2\phi + 1, 3\phi + 2, 5\phi + 3, \dots$.
 Write down the next term, ϕ^6 , in the form $a\phi + b$ where a and b are integers. [1]

.....

- 4 Find the length of HF in Fig. 3 in surd form, simplifying your answer. [3]

.....

5 On lines 84 to 87 it is stated that the equation of the line BD is $\phi y + x = \phi$ and the equation of the line CF is $(\phi - 1)y = x - 1$.

(i) Write down the gradients of these lines in terms of ϕ . [2]

(ii) Show that these lines are perpendicular. [2]

(i) Gradient of line BD is

Gradient of line CF is

(ii)
.....
.....
.....

6 On line 90 it is stated that the point Q has coordinates $\left(\frac{\phi + 1}{2\phi - 1}, \frac{\phi - 1}{2\phi - 1}\right)$, where $\phi = \frac{1 + \sqrt{5}}{2}$.

Show that the x -coordinate is $\frac{5 + 3\sqrt{5}}{10}$. [3]

.....
.....
.....
.....

7 The arithmetic sequence $a, a + d, a + 2d, a + 3d, \dots$ is an additive sequence. Prove that $a = 0$ and $d = 0$. [3]

.....
.....
.....
.....

Permission to reproduce items where third-party owned material protected by copyright is included has been sought and cleared where possible. Every reasonable effort has been made by the publisher (OCR) to trace copyright holders, but if any items requiring clearance have unwittingly been included, the publisher will be pleased to make amends at the earliest possible opportunity.

OCR is part of the Cambridge Assessment Group. Cambridge Assessment is the brand name of University of Cambridge Local Examinations Syndicate (UCLES), which is itself a department of the University of Cambridge.

**ADVANCED GCE
MATHEMATICS (MEI)**

4754/01B

Applications of Advanced Mathematics (C4) Paper B: Comprehension

INSERT

TUESDAY 22 JANUARY 2008

Afternoon
Time: Up to 1 hour

INSTRUCTIONS TO CANDIDATES

- This insert contains the text for use with the questions.

This document consists of **8** printed pages.

The Golden Ratio

Introduction

In mathematics there are many important constants. You have met some of these, such as π , the ratio of the circumference of a circle to its diameter, and e , the base of natural logarithms.

In this article, you will be introduced to another important constant and some of its properties, one of which is linked to sequences. 5

Geometric sequences

The sequence

$$1, x, x^2, x^3, x^4, x^5, \dots \quad (*)$$

is a geometric sequence with first term 1 and common ratio x . You can substitute various values for x and each one will generate a new geometric sequence. 10

For example, $x = 3$ generates the geometric sequence

$$1, 3, 9, 27, 81, 243, \dots$$

and $x = -\frac{1}{2}$ generates the geometric sequence

$$1, -\frac{1}{2}, \frac{1}{4}, -\frac{1}{8}, \frac{1}{16}, -\frac{1}{32}, \dots \quad 15$$

Notice that neither of these is an arithmetic sequence, prompting the following question.

Are there any values of x for which the geometric sequence generated is also an arithmetic sequence?

In order to answer this question, it is helpful to think about the first three terms of the sequence (*).

Suppose that $1, x, x^2$ are the first three terms of an arithmetic sequence. Then the difference between the first two terms, $x - 1$, is equal to the difference between the next two terms, $x^2 - x$, so that 20

$$x - 1 = x^2 - x.$$

This equation can be written in the form $x^2 - 2x + 1 = 0$. This has a repeated root of $x = 1$; the only value of x for which $1, x, x^2, \dots$ is both an arithmetic and a geometric sequence is $x = 1$.

You will notice that $x = 1$ leads to the rather uninteresting sequence $1, 1, 1, 1, 1, \dots$ 25

Additive sequences

In the Fibonacci sequence, the first two terms are given as 1, 1. After that, each term is the sum of the two previous terms. The Fibonacci sequence is

$$1, 1, 2, 3, 5, 8, 13, 21, 34, \dots$$

Another sequence with the same property, that each term is the sum of the two previous terms, is the Lucas sequence 30

$$2, 1, 3, 4, 7, 11, 18, 29, \dots$$

In general, you can choose any two numbers for the first two terms, call them u_1 and u_2 , and then use the rule

$$u_{n+1} = u_n + u_{n-1} \text{ for } n \geq 2 \quad 35$$

to generate subsequent terms. For the purposes of this article, any sequence with this property will be called an *additive sequence*.

Now think again about the geometric sequence (*). Are there any values of x for which this sequence is an additive sequence?

To be an additive sequence, x must satisfy each of the following equations. 40

$$\begin{aligned} x^2 &= x + 1 \\ x^3 &= x^2 + x \\ x^4 &= x^3 + x^2 \\ &\vdots \end{aligned}$$

The first equation shows that $x \neq 0$. So each of the other equations reduces to the quadratic equation $x^2 = x + 1$. The two roots of this quadratic equation are $x = \frac{1 + \sqrt{5}}{2}$ and $x = \frac{1 - \sqrt{5}}{2}$. Therefore these are the only two values of x for which the sequence (*) is both a geometric sequence and an additive sequence. 45

The Golden Ratio

The first of these numbers, $\frac{1 + \sqrt{5}}{2}$, is called the Golden Ratio and is denoted by the Greek letter ϕ , pronounced 'phi'. 50

Substituting $x = \phi$ in the sequence (*) gives

$$1, \phi, \phi^2, \phi^3, \phi^4, \phi^5, \dots$$

When written in this form, it is not at all obvious that it is an additive sequence. However, using the fact that $\phi^2 = \phi + 1$, the third term can be written as $\phi + 1$ and the fourth term, ϕ^3 , can be written as $\phi^2 + \phi$ which simplifies to $2\phi + 1$. Continuing in this way, the sequence can be written as 55

$$1, \phi, \phi + 1, 2\phi + 1, 3\phi + 2, 5\phi + 3, \dots$$

confirming the additive property $u_{n+1} = u_n + u_{n-1}$.

The Golden Rectangle

The rectangle ABCD in Fig. 1 has width $\phi = \frac{1 + \sqrt{5}}{2}$ units and height 1 unit.

60

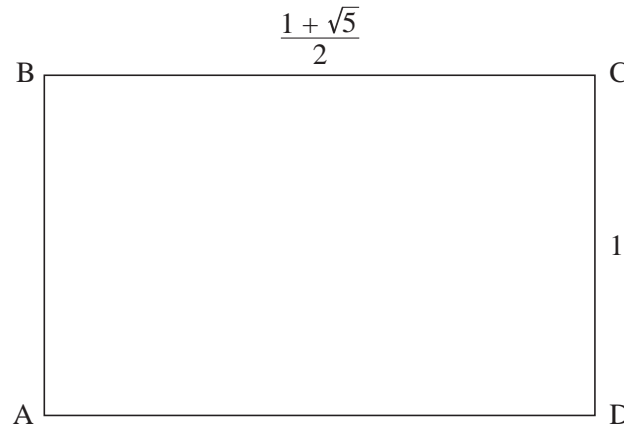

Fig. 1

The ratio of the sides of this rectangle is $\frac{1 + \sqrt{5}}{2} : 1$.

Many artists and architects believe that, of all rectangles, ones with this ratio are particularly pleasing to the human eye. For this reason approximations to these rectangles have been used extensively in art and architecture.

Any rectangle with sides in the ratio $\frac{1 + \sqrt{5}}{2} : 1$ is called a Golden Rectangle.

65

Golden Rectangles have many interesting properties, some of which will be described here.

First remove a unit square, ABEF, from a Golden Rectangle, as shown in Fig. 2.

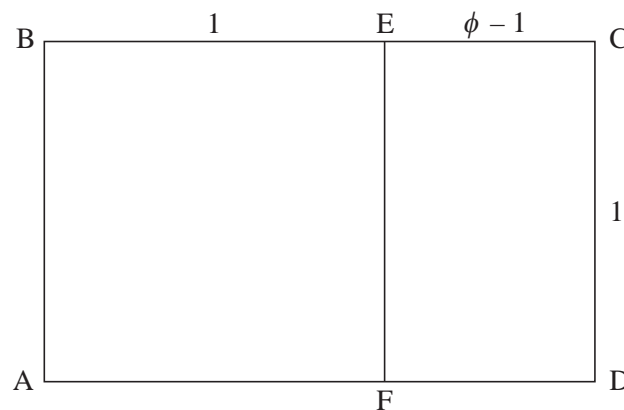

Fig. 2

Then using $\phi^2 = \phi + 1$, the ratio of the sides of rectangle ECDF may be found as follows.

$$\begin{aligned} CD : DF &= 1 : \phi - 1 \\ &= \phi : \phi^2 - \phi \\ &= \phi : 1 \end{aligned}$$

70

Therefore the ratio is the same for rectangle ECDF as for rectangle ABCD. So rectangle ECDF is also a Golden Rectangle.

This shows a property of a Golden Rectangle: any Golden Rectangle can be divided into a square and a smaller Golden Rectangle. 75

So if you remove a square ECGH from the Golden Rectangle ECDF, as shown in Fig. 3, then the ratio of the sides of rectangle FHGD is the same as that for rectangle ABCD.

This implies that the point H must lie on the line BD.

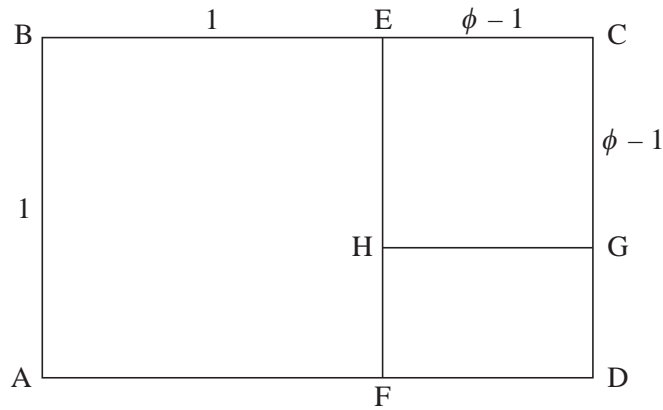

Fig. 3

Continuing in this way, removing a square from the Golden Rectangle just constructed, you can form a sequence of Golden Rectangles as shown in Fig. 4. The lines BD and CF are also shown. 80

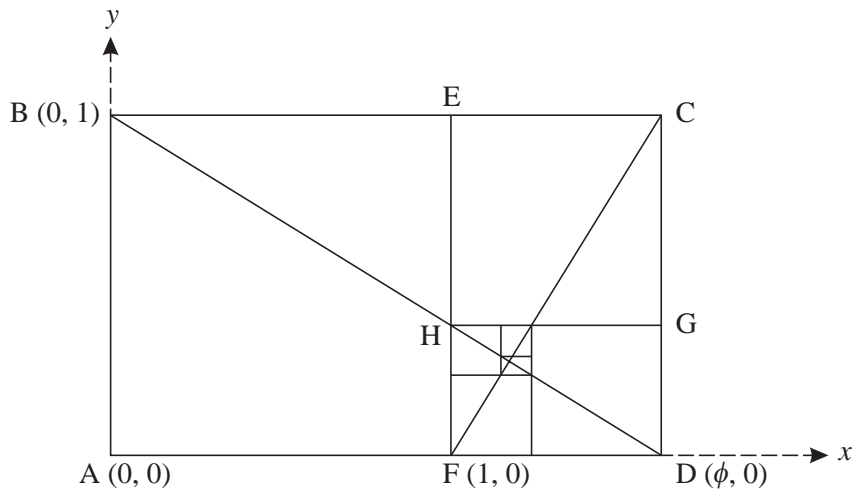

Fig. 4

This process can be continued indefinitely, each rectangle generated being similar to the original rectangle ABCD. Each square has a corner on the line BD and another corner on the line CF.

Taking A as the origin, AD as the positive x -axis and AB as the positive y -axis, as in Fig. 4, it can be shown that the equation of the line BD is

$$\phi y + x = \phi$$

and the equation of the line CF is

$$(\phi - 1)y = x - 1,$$

where $\phi = \frac{1 + \sqrt{5}}{2}$.

It follows that lines BD and CF are perpendicular and Q , the point of intersection of these two lines, has coordinates $\left(\frac{\phi+1}{2\phi-1}, \frac{\phi-1}{2\phi-1}\right)$.

90

Spirals

In Fig. 5, circular arcs have been drawn in each square. Arc AE has centre F , arc EG has centre H , and so on.

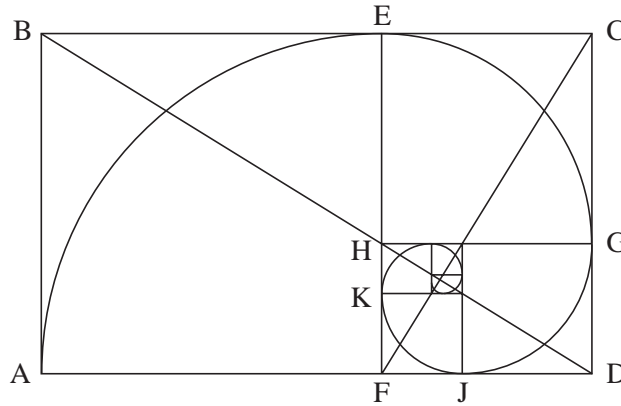

Fig. 5

In this spiral, the radius changes abruptly as it moves into each new square. For example, at the point E the radius changes from 1 unit in square $ABEF$ to $\frac{-1+\sqrt{5}}{2}$ units in square $ECGH$.

95

It is, however, possible to construct a spiral through points A, E, G, J, K and so on (see Fig. 6) in a different way so that these 'jumps' are smoothed out.

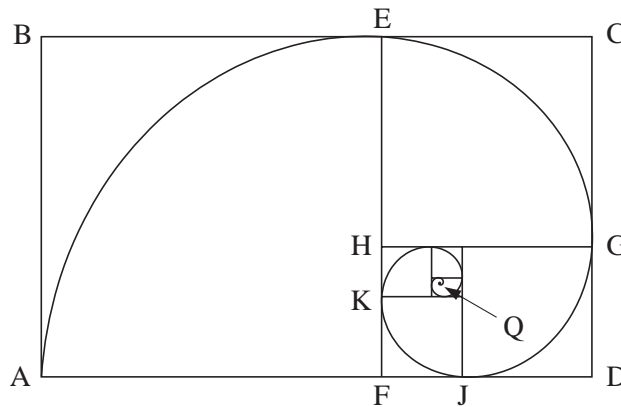

Fig. 6

As a point P moves along the resulting spiral from A towards Q , the distance QP decreases uniformly. During each full turn, the distance QP decreases by a constant factor of

$$\phi^4 = \left(\frac{1+\sqrt{5}}{2}\right)^4 = \frac{7+3\sqrt{5}}{2} \approx 6.9.$$

100

For example, if you draw a straight line from Q, such as the one shown in Fig. 7, and measure the distances QP_1 and QP_2 you will find that $QP_1 \approx 6.9 \times QP_2$.

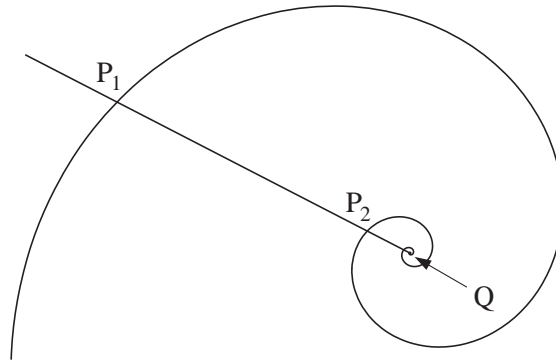

Fig. 7

This spiral is called a logarithmic spiral. It has the property that, although any two segments of the spiral differ in size, they have the same shape. If you zoomed in near the centre of the spiral and then enlarged this view, the shape would fit exactly onto the original spiral.

105



© iStockphoto.com / Horst Gossmann

Fig. 8

Fig. 8 is a photograph of the shell of a nautilus, a marine creature. The shape of the shell forms a logarithmic spiral. This is just one of many examples where the Golden Ratio may be found in the natural world.

Acknowledgements:

Fig. 8 © iStockphoto.com / Horst Gossmann

Permission to reproduce items where third-party owned material protected by copyright is included has been sought and cleared where possible. Every reasonable effort has been made by the publisher (OCR) to trace copyright holders, but if any items requiring clearance have unwittingly been included, the publisher will be pleased to make amends at the earliest possible opportunity.

OCR is part of the Cambridge Assessment Group. Cambridge Assessment is the brand name of University of Cambridge Local Examinations Syndicate (UCLES), which is itself a department of the University of Cambridge.

4754 (C4) Applications of Advanced Mathematics

Section A

<p>1 $3 \cos \theta + 4 \sin \theta = R \cos(\theta - \alpha)$ $= R(\cos \theta \cos \alpha + \sin \theta \sin \alpha)$ $\Rightarrow R \cos \alpha = 3, R \sin \alpha = 4$ $\Rightarrow R^2 = 3^2 + 4^2 = 25 \Rightarrow R = 5$ $\tan \alpha = 4/3 \Rightarrow \alpha = 0.9273$</p> <p>$5 \cos(\theta - 0.9273) = 2$ $\Rightarrow \cos(\theta - 0.9273) = 2/5$ $\theta - 0.9273 = 1.1593, -1.1593$ $\Rightarrow \theta = 2.087, -0.232$</p>	<p>M1 B1 M1A1</p> <p>M1 A1 A1 [7]</p>	<p>$R = 5$ cwo</p> <p>and no others in the range</p>
<p>2(i) $(1-2x)^{-\frac{1}{2}} = 1 - \frac{1}{2}(-2x) + \frac{(-\frac{1}{2})(-\frac{3}{2})}{2!}(-2x)^2 + \dots$ $= 1 + x + \frac{3}{2}x^2 + \dots$ Valid for $-1 < -2x < 1 \Rightarrow -\frac{1}{2} < x < \frac{1}{2}$</p>	<p>M1 A1</p> <p>A1 M1 A1 [5]</p>	<p>binomial expansion with $p = -\frac{1}{2}$ correct expression</p> <p>cao</p>
<p>(ii) $\frac{1+2x}{\sqrt{1-2x}} = (1+2x)(1+x+\frac{3}{2}x^2+\dots)$ $= 1+x+\frac{3}{2}x^2+2x+2x^2+\dots$ $= 1+3x+\frac{7}{2}x^2+\dots$</p>	<p>M1</p> <p>A1ft</p> <p>A1 [3]</p>	<p>substituting their $1+x+\frac{3}{2}x^2+\dots$ and expanding</p> <p>cao</p>
<p>3 $V = \int_1^2 \pi x^2 dy$ $y = 1 + x^2 \Rightarrow x^2 = y - 1$ $\Rightarrow V = \int_1^2 \pi(y-1) dy$ $= \pi \left[\frac{1}{2}y^2 - y \right]_1^2$ $= \pi(2 - 2 - \frac{1}{2} + 1)$ $= \frac{1}{2} \pi$</p>	<p>B1</p> <p>M1</p> <p>B1</p> <p>M1 A1 [5]</p>	<p>$\left[\frac{1}{2}y^2 - y \right]$</p> <p>substituting limits into integrand</p>

<p>4(i) $\sin(\theta + 45^\circ) = \cos \theta$ $\Rightarrow \sin \theta \cos 45 + \cos \theta \sin 45 = \cos \theta$ $\Rightarrow (1/\sqrt{2}) \sin \theta + (1/\sqrt{2}) \cos \theta = \cos \theta$ $\Rightarrow \sin \theta + \cos \theta = \sqrt{2} \cos \theta$ $\Rightarrow \sin \theta = (\sqrt{2} - 1) \cos \theta$ $\Rightarrow \frac{\sin \theta}{\cos \theta} = \tan \theta = \sqrt{2} - 1 *$</p>	<p>M1 B1 A1 M1 E1 [5]</p>	<p>compound angle formula $\sin 45 = 1/\sqrt{2}$, $\cos 45 = 1/\sqrt{2}$ collecting terms</p>
<p>(ii) $\tan \theta = \sqrt{2} - 1$ $\Rightarrow \theta = 22.5^\circ,$ 202.5°</p>	<p>B1 B1 [2]</p>	<p>and no others in the range</p>
<p>5 $\frac{4}{x(x^2 + 4)} = \frac{A}{x} + \frac{Bx + C}{x^2 + 4}$ $= \frac{A(x^2 + 4) + (Bx + C)x}{x(x^2 + 4)}$ $\Rightarrow 4 = A(x^2 + 4) + (Bx + C)x$ $x = 0 \Rightarrow 4 = 4A \Rightarrow A = 1$ coefft of x^2: $0 = A + B \Rightarrow B = -1$ coeffts of x: $0 = C$ $\Rightarrow \frac{4}{x(x^2 + 4)} = \frac{1}{x} - \frac{x}{x^2 + 4}$</p>	<p>M1 M1 B1 DM1 A1 A1 [6]</p>	<p>correct partial fractions A=1 Substitution or equating coeffts B= -1 C= 0</p>
<p>6 $\operatorname{cosec} \theta = 3$ $\Rightarrow \sin \theta = 1/3$ $\Rightarrow \theta = 19.47^\circ,$ 160.53°</p>	<p>M1 A1 A1 [3]</p>	<p>and no others in the range</p>

Section B

<p>7(i) $\overline{CD} = \begin{pmatrix} -6 \\ 6 \\ 24 \end{pmatrix}$ $\overline{CB} = \begin{pmatrix} 0 \\ 20 \\ 0 \end{pmatrix}$.</p>	<p>B1 B1 [2]</p>	
<p>(ii) $\sqrt{(-6)^2 + 6^2 + 24^2}$ = 25.46 cm</p>	<p>M1 A1 [2]</p>	
<p>(iii) $\overline{CD} \cdot \begin{pmatrix} 4 \\ 0 \\ 1 \end{pmatrix} = \begin{pmatrix} -6 \\ 6 \\ 24 \end{pmatrix} \cdot \begin{pmatrix} 4 \\ 0 \\ 1 \end{pmatrix} = -24 + 0 + 24 = 0$ $\overline{CB} \cdot \begin{pmatrix} 4 \\ 0 \\ 1 \end{pmatrix} = \begin{pmatrix} 0 \\ 20 \\ 0 \end{pmatrix} \cdot \begin{pmatrix} 4 \\ 0 \\ 1 \end{pmatrix} = 0 + 0 + 0 = 0$ \Rightarrow plane BCDE is $4x + z = c$ At C (say) $4 \times 15 + 0 = c \Rightarrow c = 60$ \Rightarrow plane BCDE is $4x + z = 60$</p>	<p>M1 A1 B1 M1 A1 [5]</p>	<p>using scalar product or other equivalent methods</p>
<p>(iv) OG: $\mathbf{r} = \begin{pmatrix} 0 \\ 0 \\ 0 \end{pmatrix} + \lambda \begin{pmatrix} 3 \\ 6 \\ 24 \end{pmatrix}$ AF: $\mathbf{r} = \begin{pmatrix} 0 \\ 20 \\ 0 \end{pmatrix} + \mu \begin{pmatrix} 3 \\ -6 \\ 24 \end{pmatrix}$ At (5, 10, 40), $3\lambda = 5 \Rightarrow \lambda = 5/3$ $\Rightarrow 6\lambda = 10, 24\lambda = 40$, so consistent. At (5, 10, 40), $3\mu = 5 \Rightarrow \mu = 5/3$ $\Rightarrow 20 - 6\mu = 10, 24\mu = 40$, so consistent. So lines meet at (5, 10, 40)*</p>	<p>B1 B1 M1 E1 E1 [5]</p>	<p>evaluating parameter and checking consistency. [or other methods, e.g. solving]</p>
<p>(v) $h=40$ POABC: $V = 1/3 \times 20 \times 15 \times 40$ $= 4000 \text{ cm}^3$. PDEFG: $V = 1/3 \times 8 \times 6 \times (40-24)$ $= 256 \text{ cm}^3$ \Rightarrow vol of ornament = $4000 - 256 = 3744 \text{ cm}^3$</p>	<p>B1 M1 A1 A1 [4]</p>	<p>soi $1/3 \times w \times d \times h$ used for either –condone one error both volumes correct cao</p>

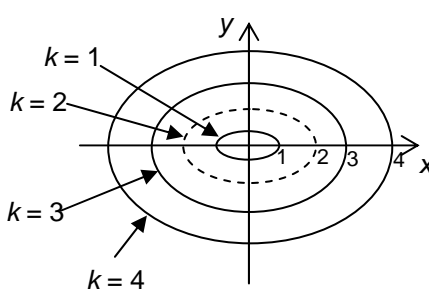
<p>8(i) $\cos \theta = \frac{x}{k}, \sin \theta = \frac{2y}{k}$ $\cos^2 \theta + \sin^2 \theta = 1$ $\Rightarrow \left(\frac{x}{k}\right)^2 + \left(\frac{2y}{k}\right)^2 = 1$ $\Rightarrow \frac{x^2}{k^2} + \frac{4y^2}{k^2} = 1$ $\Rightarrow x^2 + 4y^2 = k^2 *$</p>	<p>M1 M1 E1 [3]</p>	<p>Used substitution</p>
<p>(ii) $\frac{dx}{d\theta} = -k \sin \theta, \frac{dy}{d\theta} = \frac{1}{2}k \cos \theta$ $\frac{dy}{dx} = \frac{dy/d\theta}{dx/d\theta} = -\frac{\frac{1}{2}k \cos \theta}{k \sin \theta}$ $= -\frac{1}{2} \cot \theta$ $-\frac{x}{4y} = -\frac{2k \cos \theta}{4k \sin \theta} = -\frac{1}{2} \cot \theta = \frac{dy}{dx}$</p>	<p>M1 A1 E1</p>	<p>oe</p>
<p>or, by differentiating implicitly $2x + 8y \, dy/dx = 0$ $\Rightarrow \, dy/dx = -2x/8y = -x/4y*$</p>	<p>M1 A1 E1 [3]</p>	
<p>(iii) $k = 2$</p>	<p>B1 [1]</p>	
<p>(iv)</p> 	<p>B1 B1 B1 [3]</p>	<p>1 correct curve –shape and position 2 or more curves correct shape- in concentric form all 3 curves correct</p>
<p>(v) grad of stream path = $-1/\text{grad of contour}$ $\Rightarrow \frac{dy}{dx} = -\frac{1}{(-x/4y)} = \frac{4y}{x} *$</p>	<p>M1 E1 [2]</p>	
<p>(vi) $\frac{dy}{dx} = \frac{4y}{x} \Rightarrow \int \frac{dy}{y} = \int \frac{4dx}{x}$ $\Rightarrow \ln y = 4 \ln x + c = \ln e^c x^4$ $\Rightarrow y = Ax^4$ where $A = e^c$.</p> <p>When $x = 2, y = 1 \Rightarrow 1 = 16A \Rightarrow A = 1/16$ $\Rightarrow y = x^4/16 *$</p>	<p>M1 A1 M1 M1 A1 E1 [6]</p>	<p>Separating variables $\ln y = 4 \ln x (+c)$ antilogging correctly (at any stage) substituting $x = 2, y = 1$ evaluating a correct constant www</p>

Paper B Comprehension 4754 (C4)

1	4, 1, 5, 6, 11, 17	B1 B1	for 11 and 17 for 1 and 4
2	Even, odd, odd, even, odd, odd recurs 100 th term is therefore even	M1 A1	for reason www
3	$\phi^6 = (3\phi + 2) + (5\phi + 3) = 8\phi + 5$	B1	
4	$1 - EH = 1 - CG = 1 - (\phi - 1)$ $= 2 - \phi = 2 - \left(\frac{1 + \sqrt{5}}{2}\right)$ $= \frac{3 - \sqrt{5}}{2}$	M1 A1 A1	oe
5	(i) Gradients $-\frac{1}{\phi}$ and $\frac{1}{\phi - 1}$ (ii) Product of gradients: $-\frac{1}{\phi} \times \frac{1}{\phi - 1} = -\frac{1}{\phi^2 - \phi}$ $= -\frac{1}{1} = -1$	B1 B1 M1 E1	
6	$\frac{\phi + 1}{2\phi - 1} = \frac{\frac{1 + \sqrt{5}}{2} + 1}{1 + \sqrt{5} - 1}$ $= \frac{3 + \sqrt{5}}{2\sqrt{5}}$ $= \frac{(3 + \sqrt{5})\sqrt{5}}{2\sqrt{5} \times \sqrt{5}} = \frac{3\sqrt{5} + 5}{10}$	M1 A1 E1	
7	$a + (a + d) = a + 2d \Rightarrow a = d$ $(a + d) + (a + 2d) = a + 3d \Rightarrow a = 0$ $a = d = 0$ *	M1 M1 E1 [18]	

4754: Applications of Advanced Mathematics (C4)

General Comments

There is always a comparatively small entry for this examination in the January session compared to that in June. The overall standard of work in January has generally been higher than in the summer and this paper proved to be no exception.

The papers proved to be very straightforward. All questions were answered well by most candidates- both in Paper A and the Comprehension - and high scores were achieved by a large number of candidates.

Candidates should however be advised that when an answer is given in the question, a full explanation of how that answer is established **must** be given. The omission of brackets was also a disappointingly common failure which leads to subsequent errors and the loss of marks.

Comments on Individual Questions

Paper A

Section A

- 1) This proved to be a relatively straightforward application of the method for solving equations of the type $3\cos\theta + 4\sin\theta = 2$. There were two common errors. The first was the use of degrees rather than the required radians. The other was either to only find one solution in the final part or to give \pm the same solution e.g. $+2.087$ and -2.087 . Otherwise, this question was usually answered correctly.
- 2)
 - (i) Binomial expansions with $n = \frac{1}{2}$ or -1 were sometimes seen but the expansions were usually correct. The powers of $-2x$ caused some errors, particularly among those who failed to use brackets. The most common errors involved the set of values for the validity. This was either omitted or equality signs were included in the statement or in some cases, only one end point was given.
 - (ii) Most candidates correctly used their expansion from part (i) in part (ii).
- 3) There were many completely correct solutions for this volume of revolution. However, some candidates gave confused answers. Those who integrated a function of y wrt y and between y limits were usually successful. Too many substituted y limits into an expression in x . Trying to integrate $(1+x^2)^2$ wrt y was common.
- 4) This was generally well answered. Weaker candidates failed to collect terms but the majority obtained full marks in both parts (i) and (ii).
- 5) This was well answered by the many candidates that started with the correct form of the partial fractions. However, $\frac{4}{x(x^2+4)} = \frac{A}{x} + \frac{B}{x^2+4}$ or $\frac{A}{x} + \frac{Bx}{x^2+4}$ were too often incorrectly seen as the starting points.
- 6) This question was usually correctly answered. Occasionally $1/\operatorname{cosec}\theta = \cos\theta$ was incorrectly used, or only one solution was found.

Section B

- 7) (i) The vectors were almost always right.
- (ii) The method and answer for finding the length was usually correct.
- (iii) Some candidates failed to show sufficient working that the two vectors were perpendicular.

$$\begin{pmatrix} -6 \\ 6 \\ 24 \end{pmatrix} \cdot \begin{pmatrix} 4 \\ 0 \\ 1 \end{pmatrix} = 0 \text{ is not enough --working needs to be shown.}$$

The cartesian equation of the plane was sometimes omitted or possibly overlooked. Starting from the vector equation of the plane and then converting to cartesian form was seen, but most used the easier $4x+z = c$ as their starting point.

- (iv) The vector equations were usually correct but many candidates did not clearly establish that $(5,10,40)$ was on both lines. A common error was to use the same parameter, usually λ , for both of the vector equations and then solve to find the value of the parameter. For those that solved equations correctly to find both their parameters, many failed to show that the point lay on both lines or failed to make it clear that their solutions for their parameters satisfied all three equations.
- The volume of the ornament was often well done-even by weaker candidates.
- (v) The most frequent error was failing to realise that the perpendicular height of POABC was 40cm. Some candidates used a slant height and others assumed, incorrectly, that the pyramid was a right pyramid and used Pythagoras to calculate the height.
- 8) (i) The verification was almost always correct. In some cases $\cos^2\theta + \sin^2\theta = 1$ was not clearly stated.
- (ii) The differentiation was usually correct. Most differentiated the parameters and then divided but the use of implicit differentiation was also fairly common and successful.
- (iii) $k=2$ was usually found. $k=\sqrt{8}$ was the most common error.

Report on the Units taken in January 2008

- (iv) The graphs were well answered-often with a great deal of detail for a sketch. The most common error was failing to give a scale on the y axis.
- (v) Although most candidates understood the idea that these gradients were the negative reciprocals of one another, their explanations were sometimes incomplete. References to the 'inverse' or the 'normal' were seen. There were, however, many good answers.
- (vi) Few candidates obtained full marks in this part. Although most candidates separated the variables correctly and integrated there were many errors. $\int \frac{1}{4y} dy = \ln 4y$ was a common error. Candidates still fail to perform log rules correctly. For example, $\ln y = 4 \ln x + c \Rightarrow y = x^4 + c$ is still often seen. Also, $\frac{1}{4} \ln 4y = \ln 4y^{\frac{1}{4}}$ without the use of brackets often lead to $4xy^{\frac{1}{4}}$ instead of $(4y)^{\frac{1}{4}}$ causing subsequent errors. Some candidates still failed to include a constant of integration.

Paper B: The Comprehension

- 1) The values 4,1,...11,17 were almost always correct.
- 2) This was usually correct although explanations were not always clear. Some gave good algebraic reasons based on the $3n+1$ th term. Most spotted the pattern of odd and even terms. There were incorrect answers and explanations such as every fourth term is even.
- 3) $8\phi+5$ was usually correct.
- 4) The method was often correct but poor use of brackets often lead to the answer being incorrectly given as $(3+\sqrt{5})/2$. Although most candidates approached from $2-\phi$ there were equally good answers from different starting points-often $(\phi-1)/\phi$.
- 5) (i) These gradients were often correct.
(ii) There were some good explanations showing why these lines were perpendicular. Some used a variety of equations in terms of ϕ and many substituted $(1+\sqrt{5})/2$ and worked in surds. There were many other cases where the justification was poor.
- 6) The substitution was usually correct but the rationalisation of the denominator was not always clear. The answer was given in the question and so justification of $\frac{3+\sqrt{5}}{2\sqrt{5}} = \frac{5+3\sqrt{5}}{10}$ was needed.
- 7) There were some good solutions here but some did not really understand what was required. Some found $2a+d=a+2d$ and then equated terms or just stated $a=d=0$ and others made algebraic errors.

Grade Thresholds

Jan 2008 Examination Series

Unit Threshold Marks

Unit		Maximum mark	A	B	C	D	E	U
All units	UMS	100	80	70	60	50	40	0
4754	Raw	90	77	68	59	50	41	0

**ADVANCED GCE
MATHEMATICS (MEI)**

4754/01A

Applications of Advanced Mathematics (C4) Paper A

WEDNESDAY 21 MAY 2008

Afternoon

Time: 1 hour 30 minutes

Additional materials: Answer Booklet (8 pages)
Graph paper
MEI Examination Formulae and Tables (MF2)

INSTRUCTIONS TO CANDIDATES

- Write your name in capital letters, your Centre Number and Candidate Number in the spaces provided on the Answer Booklet.
- Read each question carefully and make sure you know what you have to do before starting your answer.
- Answer **all** the questions.
- You are permitted to use a graphical calculator in this paper.
- Final answers should be given to a degree of accuracy appropriate to the context.

INFORMATION FOR CANDIDATES

- The number of marks is given in brackets [] at the end of each question or part question.
- The total number of marks for this paper is 72.
- You are advised that an answer may receive **no marks** unless you show sufficient detail of the working to indicate that a correct method is being used.

NOTE

- This paper will be followed by **Paper B: Comprehension**.

This document consists of 4 printed pages.

Section A (36 marks)

1 Express $\frac{x}{x^2 - 4} + \frac{2}{x + 2}$ as a single fraction, simplifying your answer. [3]

2 Fig. 2 shows the curve $y = \sqrt{1 + e^{2x}}$.

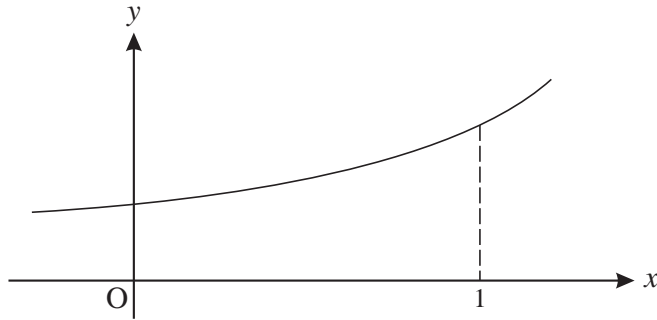

Fig. 2

The region bounded by the curve, the x -axis, the y -axis and the line $x = 1$ is rotated through 360° about the x -axis.

Show that the volume of the solid of revolution produced is $\frac{1}{2}\pi(1 + e^2)$. [4]

3 Solve the equation $\cos 2\theta = \sin \theta$ for $0 \leq \theta \leq 2\pi$, giving your answers in terms of π . [7]

4 Given that $x = 2 \sec \theta$ and $y = 3 \tan \theta$, show that $\frac{x^2}{4} - \frac{y^2}{9} = 1$. [3]

5 A curve has parametric equations $x = 1 + u^2$, $y = 2u^3$.

(i) Find $\frac{dy}{dx}$ in terms of u . [3]

(ii) Hence find the gradient of the curve at the point with coordinates (5, 16). [2]

6 (i) Find the first three non-zero terms of the binomial series expansion of $\frac{1}{\sqrt{1 + 4x^2}}$, and state the set of values of x for which the expansion is valid. [5]

(ii) Hence find the first three non-zero terms of the series expansion of $\frac{1 - x^2}{\sqrt{1 + 4x^2}}$. [3]

7 Express $\sqrt{3} \sin x - \cos x$ in the form $R \sin(x - \alpha)$, where $R > 0$ and $0 < \alpha < \frac{1}{2}\pi$. Express α in the form $k\pi$.

Find the exact coordinates of the maximum point of the curve $y = \sqrt{3} \sin x - \cos x$ for which $0 < x < 2\pi$. [6]

- 9 A skydiver drops from a helicopter. Before she opens her parachute, her speed $v \text{ m s}^{-1}$ after time t seconds is modelled by the differential equation

$$\frac{dv}{dt} = 10e^{-\frac{1}{2}t}.$$

When $t = 0$, $v = 0$.

- (i) Find v in terms of t . [4]

- (ii) According to this model, what is the speed of the skydiver in the long term? [2]

She opens her parachute when her speed is 10 m s^{-1} . Her speed t seconds after this is $w \text{ m s}^{-1}$, and is modelled by the differential equation

$$\frac{dw}{dt} = -\frac{1}{2}(w-4)(w+5).$$

- (iii) Express $\frac{1}{(w-4)(w+5)}$ in partial fractions. [4]

- (iv) Using this result, show that $\frac{w-4}{w+5} = 0.4e^{-4.5t}$. [6]

- (v) According to this model, what is the speed of the skydiver in the long term? [2]

Permission to reproduce items where third-party owned material protected by copyright is included has been sought and cleared where possible. Every reasonable effort has been made by the publisher (OCR) to trace copyright holders, but if any items requiring clearance have unwittingly been included, the publisher will be pleased to make amends at the earliest possible opportunity.

OCR is part of the Cambridge Assessment Group. Cambridge Assessment is the brand name of University of Cambridge Local Examinations Syndicate (UCLES), which is itself a department of the University of Cambridge.

**ADVANCED GCE
MATHEMATICS (MEI)**

4754/01B

Applications of Advanced Mathematics (C4) Paper B: Comprehension

WEDNESDAY 21 MAY 2008

Afternoon
Time: Up to 1 hour

Additional materials: Rough paper
MEI Examination Formulae and Tables (MF2)

Candidate
Forename

--

Candidate
Surname

--

Centre
Number

--	--	--	--	--

Candidate
Number

--	--	--	--

INSTRUCTIONS TO CANDIDATES

- Write your name in capital letters, your Centre Number and Candidate Number in the boxes above.
- Read each question carefully and make sure you know what you have to do before starting your answer.
- Answer **all** the questions.
- Write your answers in the spaces provided on the question paper.
- You are permitted to use a graphical calculator in this paper.
- Final answers should be given to a degree of accuracy appropriate to the context.

INFORMATION FOR CANDIDATES

- The number of marks is given in brackets [] at the end of each question or part question.
- The insert contains the text for use with the questions.
- You may find it helpful to make notes and do some calculations as you read the passage.
- You are **not** required to hand in these notes with your question paper.
- The total number of marks for this paper is 18.
- You are advised that an answer may receive **no marks** unless you show sufficient detail of the working to indicate that a correct method is being used.

FOR EXAMINER'S USE	
1	
2	
3	
4	
5	
6	
7	
TOTAL	

This document consists of **6** printed pages, **2** blank pages and an insert.

7 A man is setting a Sudoku puzzle and starts with this solution.

1	2	3	4	5	6	7	8	9
4	5	6	8	9	7	3	1	2
7	8	9	3	1	2	5	6	4
2	3	1	5	6	4	8	9	7
5	6	4	9	7	8	1	2	3
8	9	7	1	2	3	6	4	5
3	1	2	6	4	5	9	7	8
6	4	5	7	8	9	2	3	1
9	7	8	2	3	1	4	5	6

He then removes some of the numbers to give the puzzles in parts (i) and (ii). In each case explain briefly, and without trying to solve the puzzle, why it does not have a unique solution.

[2, 2]

(i)

1	2		4		6			9
4			8	9			1	
	8						6	
2		1			4			7
	6	4		7	8	1	2	
8	9			2			4	
	1		6	4		9	7	
6	4		7		9			1
9		8	2		1	4		6

(ii)

1	2	3	4	5	6	7	8	9
4	5	6	8	9	7	3	1	2
7	8	9				5	6	4
2	3	1	5	6	4	8	9	7
5	6	4	9	7	8	1	2	3
8	9	7				6	4	5
3	1	2	6	4	5	9	7	8
6	4	5	7	8	9	2	3	1
9	7	8				4	5	6

(i)

.....

.....

.....

(ii)

.....

.....

.....

BLANK PAGE

BLANK PAGE

Permission to reproduce items where third-party owned material protected by copyright is included has been sought and cleared where possible. Every reasonable effort has been made by the publisher (OCR) to trace copyright holders, but if any items requiring clearance have unwittingly been included, the publisher will be pleased to make amends at the earliest possible opportunity.

OCR is part of the Cambridge Assessment Group. Cambridge Assessment is the brand name of University of Cambridge Local Examinations Syndicate (UCLES), which is itself a department of the University of Cambridge.

**ADVANCED GCE
MATHEMATICS (MEI)**

4754/01B

Applications of Advanced Mathematics (C4) Paper B: Comprehension

INSERT

WEDNESDAY 21 MAY 2008

Afternoon
Time: Up to 1 hour

INSTRUCTIONS TO CANDIDATES

- This insert contains the text for use with the questions.

This document consists of **11** printed pages and **1** blank page.

Sudoku puzzles

Introduction

Sudoku puzzles were introduced to the UK in 2004 and almost immediately became very popular. Many people found them addictive. A common form of Sudoku puzzle uses a 9×9 grid, as illustrated in Fig. 1.

5

- A square grid consists of small squares or *cells*. In the case of the 9×9 grid, there are 81 cells.
- The square grid is also divided into a number of smaller square grids, or *blocks*. In the case of the 9×9 grid, there are 9 blocks; each of them is a 3×3 grid and so contains 9 cells.
- When the puzzle is completed, each row, each column and each block will contain each of 9 different *symbols* exactly once. The symbols used in a 9×9 Sudoku puzzle are usually the numerals 1, 2, 3, 4, 5, 6, 7, 8 and 9 but they could just as well be letters, for example A, B, C, D, E, F, G, H and I.
- The symbols in some of the cells are already provided at the start, and these are called the *givens*.
- You have to fill in the symbols in the remaining cells. If the puzzle has been set correctly, there is only one solution; it is unique.

10

15

[Warning Do not spend time in this examination trying to complete this puzzle. You are not expected to solve it.]

								1
					3		2	
		4			9			
							9	
					4	6		
	1	7		8				
				1				7
	3		5					
9						4		

Fig. 1

In this article, the term *Sudoku* is used to describe a correctly completed grid whereas *Sudoku puzzle* is used for the initial situation where there are empty cells to be filled in. A Sudoku puzzle leads

20

to a unique Sudoku, but the converse is not true; any Sudoku can be arrived at from many different possible starting points.

There are several variations on the basic Sudoku puzzle. Some involve grids of different shapes but, in this article, only those with square grids containing square blocks are considered. The size of the grid does not need to be 9×9 ; another commonly used grid is 16×16 (using the symbols 0 to 9 together with A, B, C, D, E and F), and you can even have 25×25 Sudoku puzzles. A simpler possibility is 4×4 . Thus, in this article, the side length of the grid, s , is a square number and $s = b^2$, where b is the side length of each block. 25

Questions about Sudoku puzzles 30

This article investigates three questions about 9×9 Sudoku puzzles.

1. In how many different ways can you place the symbols 1 to 9 in the 81 cells of a 9×9 Sudoku grid, subject to the Sudoku rules?
2. What is the smallest number of givens that must be provided if a puzzle is to have a unique solution? 35
3. What is the largest number of givens that can be provided without the puzzle having a unique solution?

Approach

Two different problem-solving techniques are used in this article.

- The modelling approach is to start by working with a similar but simpler problem, see what you can learn from it and then attack the real problem; in this case the simpler problem is the Latin square puzzle. 40
- The other approach is to look at the same problem but on a smaller scale; you hope for one or both of two outcomes.
 - The smaller scale case will help you to find an appropriate method. 45
 - You can build a sequence of results from several smaller cases which will suggest a possible formula for a general result.

Latin squares

In a Latin square, the grid is not divided into smaller blocks as in a Sudoku, but each symbol must appear once in each row and in each column. An example of a 4×4 Latin square is given in Fig. 2. 50

1	2	3	4
3	1	4	2
2	4	1	3
4	3	2	1

Fig. 2

Notice that this Latin square could not be the solution to a Sudoku puzzle.

All Sudokus are Latin squares, but not all Latin squares are Sudokus. Consequently there are more Latin squares of any size (other than the trivial 1×1 case) than there are Sudokus, and so the number of Latin squares provides an upper bound for the number of Sudokus.

Latin squares have been known for a long time and in medieval times were used for decoration in the Islamic world. They were re-popularised in the late 1700s by Leonhard Euler who set puzzles on them that are often said to be the predecessors of Sudokus. These days, Latin squares are widely used in experimental design in statistics. In this article a puzzle which requires you to complete a Latin square is referred to as a Latin square puzzle. 55

Investigation 1: How many 9×9 Sudokus are there? 60

The first investigation involves the number of ways that it is possible to allocate the symbols 1, 2, 3, ..., 9 to the 81 cells on a Sudoku grid.

The first approach to the problem is to look at Latin squares of different sizes.

Trivially, there is one possible 1×1 Latin square.

There are two possible 2×2 Latin squares and these are shown in Fig. 3. 65

1	2
2	1

2	1
1	2

Fig. 3

What about 3×3 Latin squares? Start by thinking about the top row.

- Choose the top left symbol first. It can be 1 or 2 or 3 so there are 3 possibilities.
- Now choose the top middle symbol; whatever the top left symbol, there are now 2 remaining symbols to choose from for this cell.
- There is only 1 possibility for the last symbol in the row, in the top right cell.
- So the number of ways of filling the cells in the top row is $3 \times 2 \times 1 = 3! = 6$.

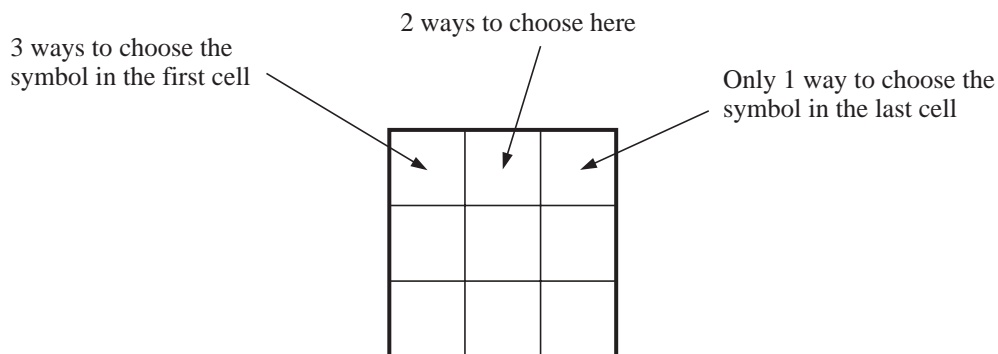

Fig. 4

Now think about the left-hand column.

- The symbol in the top cell has already been chosen.
- There remain 2 possible symbols for the middle left cell.
- There is only 1 possibility for the symbol at the bottom of the column.
- So for any given top row, the number of ways of filling the rest of the left-hand column is $2 \times 1 = 2! = 2$.

75

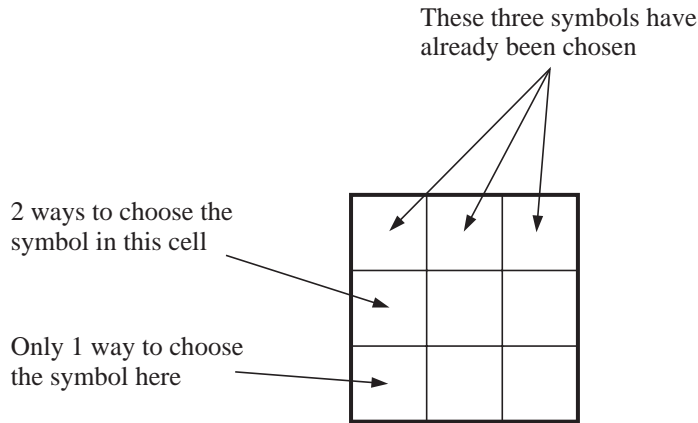

Fig. 5

In each case there is only one way to fill in the four remaining cells, as shown in the example below where the top row is (1 2 3) and the left-hand column is (1 3 2).

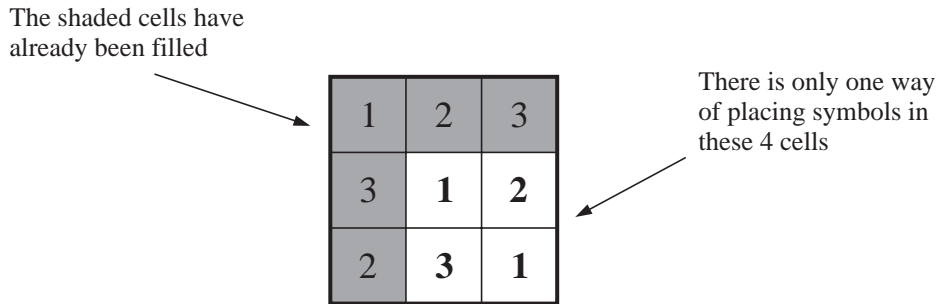

Fig. 6

So the number of 3×3 Latin squares is given by

80

$$\begin{array}{r}
 \text{Top row} \\
 6 \\
 \text{i.e. } 3!
 \end{array}
 \times
 \begin{array}{r}
 \text{Left-hand column} \\
 2 \\
 2!
 \end{array}
 \times
 \begin{array}{r}
 \text{Rest} \\
 1 \\
 1
 \end{array}
 = 12.$$

This process is illustrated in Figs. 4, 5 and 6.

The next step is to investigate the 4×4 Latin square, using the same approach.

85

- The number of ways of filling the cells in the top row is $4 \times 3 \times 2 \times 1 = 4! = 24$.
- The top cell in the left-hand column has already been filled, so there are just 3 cells remaining; there are $3 \times 2 \times 1 = 3! = 6$ ways of filling these cells.
- That leaves 9 cells, as shown in the example in Fig. 7. There is nothing special about the symbols in the top row and left-hand column; they are just a typical selection.

90

1	4	2	3	
3				
2				
4				

← These 9 cells have still to be filled in

Fig. 7

The next step is to find the number of ways of filling the remaining 9 cells. The answer turns out to be 4.

So the total number of 4×4 Latin squares is given by

$$\begin{array}{ccccccc} \text{Top row} & & \text{Left-hand column} & & \text{Rest} & & \\ 4! & \times & 3! & \times & 4 & = & 576. \end{array}$$

95

A similar procedure can be used to find the number of 5×5 Latin squares. Considering the top row and the left-hand column gives $5! \times 4!$ but counting the rest is distinctly messy. There are actually 56 ways, so the number of 5×5 Latin squares is $5! \times 4! \times 56 = 161\,280$.

The hope that finding the numbers of Latin squares of sides 1, 2, 3, 4, ... would suggest a possible formula now looks rather forlorn.

100

Table 8 gives the numbers of Latin squares for sides of up to 11. The sequence is remarkable because the numbers get so large so quickly. At the time of writing this article, no general formula is known and no-one has worked out the exact number for 12 or beyond.

Side	Number of Latin squares
1	1
2	2
3	12
4	576
5	161 280
6	812 851 200
7	61 479 419 904 000
8	108 776 032 459 082 956 800
9	5 524 751 496 156 892 842 531 225 600
10	9 982 437 658 213 039 871 725 064 756 920 320 000
11	776 966 836 171 770 144 107 444 346 734 230 682 311 065 600 000

Table 8

So what does this tell you about the numbers of possible Sudokus?

The side, s , of a Sudoku grid must be a square number, so $s = 1$ or 4 or 9 or 16 or

105

Apart from the trivial case when $s = 1$, the number of possible Sudokus is always less than the number of Latin squares for the same value of s . So the number of possible 4×4 Sudokus is less than 576 and the number of 9×9 Sudokus is less than the 28-digit number in Table 8.

Given the difficulty of finding a formula for the number of Latin squares, and the fact that the Sudoku grid is by its nature more complicated, it would be surprising if there were an easy general formula for the number of Sudokus of side s .

110

It is not, however, difficult to find the number of 4×4 Sudokus, using a similar method to that for Latin squares. Fig. 9 shows one of the $4! = 24$ ways of completing the top row.

Because of Sudoku rules the symbol in this cell must be either 3 or 4

1	2	3	4

Fig. 9

It turns out that there are 16 different ways of filling in the remaining cells while keeping to the Sudoku rules. One of these ways is shown in Fig. 10.

115

1	2	3	4
3	4	2	1
2	1	4	3
4	3	1	2

Fig. 10

So there are 384 possible 4×4 Sudokus. Notice that this is indeed fewer than the 576 Latin squares of the same size.

The method used involved both logic and counting. This mixture of logic and counting has been applied successfully to the 9×9 Sudoku by Felgenhauer and Jarvis of the University of Sheffield, but with the difference that, following clever programming, the counting was done by computer. The final outcome was the 22-digit number 6 670 903 752 021 072 936 960.

120

Investigation 2 **What is the smallest number of givens that must be provided if a puzzle is to have a unique solution?**

A completed 4×4 Latin square contains the symbols 1, 2, 3 and 4. Look at Fig. 11 as a starting grid for a Latin square puzzle. There are 9 givens and 7 blank cells to be filled in. Only three of the symbols, in this case 1, 2 and 3, appear but you can still find the symbols for the remaining cells easily enough, and there is only one way of doing so.

125

2	1	3	
1	3		2
3		2	
	2		

Fig. 11

However, if only two of the four symbols, say 1 and 2, appear at the start, there must be more than one way of filling in the grid because the other two symbols, in this case 3 and 4, are interchangeable. The same is true for a 4×4 Sudoku puzzle.

130

So it is certain that for there to be a unique solution to a 4×4 Latin square or Sudoku puzzle, the givens must include at least three distinct symbols. It follows that the number of givens must be at least three.

However, a systematic search shows that there is no unique solution for either a Latin square puzzle or a Sudoku puzzle if there are just three givens.

135

The next case to try is four givens. Fig. 12 shows a Latin square puzzle with four givens and a unique solution.

1		3	
	4		
		1	

Fig. 12

Fig. 13 shows a Sudoku puzzle, also with four givens and a unique solution.

1		3	
	4	2	

Fig. 13

Interestingly, neither of these is a starting grid for the other type of puzzle.

The situation for the 9×9 Sudoku puzzle is much more complicated because of the increased number of possibilities but the required method is still systematic search, albeit with a well programmed computer. So far the smallest possible number of givens that anyone has found is 17, and many examples are now known of such puzzles, including that shown in Fig. 1. At the time of writing this article no-one has found a Sudoku puzzle with just 16 givens.

140

Investigation 3 **What is the largest number of givens that can be provided without a 9×9 Sudoku puzzle having a unique solution?**

145

Look at the 4×4 Latin square puzzle in Fig. 14. The givens cover twelve out of the sixteen cells. However, even with this number of givens, the remaining four cells cannot be filled in uniquely. There are two possible ways to complete the puzzle. This is because the four missing entries form an *embedded* Latin square.

150

4	2	3	1
		2	4
		4	2
2	4	1	3

Fig. 14

Fig. 15 shows the two possible arrangements for the symbols in the four remaining cells. In both arrangements the four symbols form their own 2×2 Latin square.

1	3
3	1

3	1
1	3

Fig. 15

The four symbols in a 2×2 embedded Latin square do not need to be next to each other but they do need to lie in the four corners of a rectangle. There are three other embedded Latin squares in Fig. 14; one of them is illustrated in Fig. 16.

155

4	2	3	1
		2	4
		4	2
2	4	1	3

Fig. 16

The situation would be the same if those twelve givens were provided for the equivalent 4×4 Sudoku puzzle.

If a Latin square puzzle has an embedded Latin square, it will be impossible to solve unless at least one of the symbols in the embedded square is a given. This is also sometimes true for a Sudoku puzzle, as in Fig. 16.

160

So the largest number of givens that can be provided without a 4×4 Latin square puzzle having a unique solution is at least twelve. In fact it is possible to prove that it is exactly twelve.

In the case of the 9×9 Sudoku puzzle shown in Fig. 17, there are 77 givens and just four cells remain to be filled. However those four form an embedded Latin square and the puzzle does not have a unique solution.

165

So the largest number of givens that can fail to give a unique solution for a 9×9 Sudoku puzzle is at least 77, and it can be proved that it is exactly 77.

7	1	8	2	5	9	3	4	6
4			3	8	7	1	9	5
5	3	9	4	1	6	8	2	7
1	4	7	6	9	3	2	5	8
8			5	4	1	9	7	3
3	9	5	8	7	2	6	1	4
2	5	4	9	3	8	7	6	1
9	7	3	1	6	5	4	8	2
6	8	1	7	2	4	5	3	9

Fig. 17

BLANK PAGE

Permission to reproduce items where third-party owned material protected by copyright is included has been sought and cleared where possible. Every reasonable effort has been made by the publisher (OCR) to trace copyright holders, but if any items requiring clearance have unwittingly been included, the publisher will be pleased to make amends at the earliest possible opportunity.

OCR is part of the Cambridge Assessment Group. Cambridge Assessment is the brand name of University of Cambridge Local Examinations Syndicate (UCLES), which is itself a department of the University of Cambridge.

4754 (C4) Applications of Advanced Mathematics

Section A

<p>1</p> $\frac{x}{x^2-4} + \frac{2}{x+2} = \frac{x}{(x-2)(x+2)} + \frac{2}{x+2}$ $= \frac{x+2(x-2)}{(x+2)(x-2)}$ $= \frac{3x-4}{(x+2)(x-2)}$	<p>M1 M1 A1 [3]</p>	<p>combining fractions correctly</p> <p>factorising and cancelling (may be $3x^2+2x-8$)</p>
<p>2</p> $V = \int_0^1 \pi y^2 dx = \int_0^1 \pi(1+e^{2x}) dx$ $= \pi \left[x + \frac{1}{2} e^{2x} \right]_0^1$ $= \pi \left(1 + \frac{1}{2} e^2 - \frac{1}{2} \right)$ $= \frac{1}{2} \pi (1+e^2)^*$	<p>M1 B1 M1 E1 [4]</p>	<p>must be π x their y^2 in terms of x</p> <p>$\left[x + \frac{1}{2} e^{2x} \right]$ only</p> <p>substituting both x limits in a function of x</p> <p>www</p>
<p>3</p> $\cos 2\theta = \sin \theta$ $\Rightarrow 1 - 2\sin^2 \theta = \sin \theta$ $\Rightarrow 1 - \sin \theta - 2\sin^2 \theta = 0$ $\Rightarrow (1 - 2\sin \theta)(1 + \sin \theta) = 0$ $\Rightarrow \sin \theta = \frac{1}{2} \text{ or } -1$ $\Rightarrow \theta = \pi/6, 5\pi/6, 3\pi/2$	<p>M1 M1 A1 M1 A1 A2,1,0 [7]</p>	<p>$\cos 2\theta = 1 - 2\sin^2 \theta$ oe substituted forming quadratic (in one variable) = 0 correct quadratic www factorising or solving quadratic $\frac{1}{2}, -1$ oe www cao</p> <p>penalise extra solutions in the range</p>
<p>4</p> $\sec \theta = x/2, \tan \theta = y/3$ $\sec^2 \theta = 1 + \tan^2 \theta$ $\Rightarrow x^2/4 = 1 + y^2/9$ $\Rightarrow x^2/4 - y^2/9 = 1^*$ <p>OR $x^2/4 - y^2/9 = 4\sec^2 \theta/4 - 9\tan^2 \theta/9 = \sec^2 \theta - \tan^2 \theta = 1$</p>	<p>M1 M1 E1 [3]</p>	<p>$\sec^2 \theta = 1 + \tan^2 \theta$ used (oe, e.g. converting to sines and cosines and using $\cos^2 \theta + \sin^2 \theta = 1$) eliminating θ (or x and y) www</p>
<p>5(i)</p> $dx/du = 2u, dy/du = 6u^2$ $\Rightarrow \frac{dy}{dx} = \frac{dy/du}{dx/du} = \frac{6u^2}{2u} = 3u$ <p>OR $y = 2(x-1)^{3/2}, dy/dx = 3(x-1)^{1/2} = 3u$</p>	<p>B1 M1 A1 [3]</p>	<p>both $2u$ and $6u^2$</p> <p>B1 ($y=f(x)$), M1 differentiation, A1</p>
<p>(ii) At (5, 16), $u = 2$</p> $\Rightarrow dy/dx = 6$	<p>M1 A1 [2]</p>	<p>cao</p>

<p>6(i) $(1+4x^2)^{-\frac{1}{2}} = 1 - \frac{1}{2} \cdot 4x^2 + \frac{(-\frac{1}{2})(-\frac{3}{2})}{2!} (4x^2)^2 + \dots$ $= 1 - 2x^2 + 6x^4 + \dots$</p> <p>Valid for $-1 < 4x^2 < 1 \Rightarrow -\frac{1}{2} < x < \frac{1}{2}$</p>	<p>M1 A1 A1 M1A1 [5]</p>	<p>binomial expansion with $p = -1/2$</p> <p>$1 - 2x^2 \dots$ $+ 6x^4$</p>
<p>(ii) $\frac{1-x^2}{\sqrt{1+4x^2}} = (1-x^2)(1-2x^2+6x^4+\dots)$ $= 1 - 2x^2 + 6x^4 - x^2 + 2x^4 + \dots$ $= 1 - 3x^2 + 8x^4 + \dots$</p>	<p>M1 A1 A1 [3]</p>	<p>substituting their $1 - 2x^2 + 6x^4 + \dots$ and expanding</p> <p>ft their expansion (of three terms)</p> <p>cao</p>
<p>7 $\sqrt{3} \sin x - \cos x = R \sin(x - \alpha)$ $= R(\sin x \cos \alpha - \cos x \sin \alpha)$ $\Rightarrow \sqrt{3} = R \cos \alpha, 1 = R \sin \alpha$ $\Rightarrow R^2 = 3 + 1 = 4 \Rightarrow R = 2$ $\tan \alpha = 1/\sqrt{3}$ $\Rightarrow \alpha = \pi/6$ $\Rightarrow y = 2 \sin(x - \pi/6)$</p> <p>Max when $x - \pi/6 = \pi/2 \Rightarrow x = \pi/6 + \pi/2 = 2\pi/3$ max value $y = 2$</p> <p>So maximum is $(2\pi/3, 2)$</p>	<p>M1 B1 M1 A1 B1 B1 [6]</p>	<p>correct pairs soi $R = 2$ ft cao www</p> <p>cao ft their R</p> <p>SC B1 $(2, 2\pi/3)$ no working</p>

Section B

<p>8(i) At A: $3 \times 0 + 2 \times 0 + 20 \times (-15) + 300 = 0$ At B: $3 \times 100 + 2 \times 0 + 20 \times (-30) + 300 = 0$ At C: $3 \times 0 + 2 \times 100 + 20 \times (-25) + 300 = 0$ So ABC has equation $3x + 2y + 20z + 300 = 0$</p>	<p>M1 A2,1,0 [3]</p>	<p>substituting co-ords into equation of plane... for ABC OR using two vectors in the plane form vector product M1A1 then $3x + 2y + 20z = c = -300$ A1 OR using vector equation of plane M1,elim both parameters M1, A1</p>
<p>(ii) $\overline{DE} = \begin{pmatrix} 100 \\ 0 \\ -10 \end{pmatrix}$ $\overline{DF} = \begin{pmatrix} 0 \\ 100 \\ 5 \end{pmatrix}$</p> <p>$\begin{pmatrix} 100 \\ 0 \\ -10 \end{pmatrix} \cdot \begin{pmatrix} 2 \\ -1 \\ 20 \end{pmatrix} = 100 \times 2 + 0 \times -1 + -10 \times 20 = 200 - 200 = 0$</p> <p>$\begin{pmatrix} 0 \\ 100 \\ 5 \end{pmatrix} \cdot \begin{pmatrix} 2 \\ -1 \\ 20 \end{pmatrix} = 0 \times 2 + 100 \times -1 + 5 \times 20 = -100 + 100 = 0$</p> <p>Equation of plane is $2x - y + 20z = c$ At D (say) $c = 20 \times -40 = -800$ So equation is $2x - y + 20z + 800 = 0$</p>	<p>B1B1 B1 B1 M1 A1 [6]</p>	<p>need evaluation need evaluation</p>
<p>(iii) Angle is θ, where</p> $\cos \theta = \frac{\begin{pmatrix} 2 \\ -1 \\ 20 \end{pmatrix} \cdot \begin{pmatrix} 3 \\ 2 \\ 20 \end{pmatrix}}{\sqrt{2^2 + (-1)^2 + 20^2} \sqrt{3^2 + 2^2 + 20^2}} = \frac{404}{\sqrt{405} \sqrt{413}}$ <p>$\Rightarrow \theta = 8.95^\circ$</p>	<p>M1 A1 A1 A1cao [4]</p>	<p>formula with correct vectors top bottom (or 0.156 radians)</p>
<p>(iv) RS: $\mathbf{r} = \begin{pmatrix} 15 \\ 34 \\ 0 \end{pmatrix} + \lambda \begin{pmatrix} 3 \\ 2 \\ 20 \end{pmatrix}$</p> $= \begin{pmatrix} 15 + 3\lambda \\ 34 + 2\lambda \\ 20\lambda \end{pmatrix}$ <p>$\Rightarrow 3(15 + 3\lambda) + 2(34 + 2\lambda) + 20 \cdot 20\lambda + 300 = 0$ $\Rightarrow 45 + 9\lambda + 68 + 4\lambda + 400\lambda + 300 = 0$ $\Rightarrow 413 + 413\lambda = 0$ $\Rightarrow \lambda = -1$ so S is (12, 32, -20)</p>	<p>B1 B1 M1 A1 A1 [5]</p>	<p>$\begin{pmatrix} 15 \\ 34 \\ 0 \end{pmatrix} + \dots$ $\dots + \lambda \begin{pmatrix} 3 \\ 2 \\ 20 \end{pmatrix}$ solving with plane $\lambda = -1$ cao</p>

<p>9(i) $v = \int 10e^{-\frac{1}{2}t} dt$ $= -20e^{-\frac{1}{2}t} + c$ when $t = 0, v = 0$ $\Rightarrow 0 = -20 + c$ $\Rightarrow c = 20$ so $v = 20 - 20e^{-\frac{1}{2}t}$</p>	M1 A1 M1 A1 [4]	separate variables and intend to integrate $-20e^{-\frac{1}{2}t}$ finding c cao
<p>(ii) As $t \rightarrow \infty$ $e^{-1/2t} \rightarrow 0$ $\Rightarrow v \rightarrow 20$ So long term speed is 20 m s^{-1}</p>	M1 A1 [2]	 ft (for their $c > 0$, found)
<p>(iii) $\frac{1}{(w-4)(w+5)} = \frac{A}{w-4} + \frac{B}{w+5}$ $= \frac{A(w+5) + B(w-4)}{(w-4)(w+5)}$ $\Rightarrow 1 \equiv A(w+5) + B(w-4)$ $w = 4: 1 = 9A \Rightarrow A = 1/9$ $w = -5: 1 = -9B \Rightarrow B = -1/9$ $\Rightarrow \frac{1}{(w-4)(w+5)} = \frac{1/9}{w-4} - \frac{1/9}{w+5}$ $= \frac{1}{9(w-4)} - \frac{1}{9(w+5)}$</p>	M1 M1 A1 A1 [4]	 cover up, substitution or equating coeffs $1/9$ $-1/9$
<p>(iv) $\frac{dw}{dt} = -\frac{1}{2}(w-4)(w+5)$ $\Rightarrow \int \frac{dw}{(w-4)(w+5)} = \int -\frac{1}{2} dt$ $\Rightarrow \int \left[\frac{1}{9(w-4)} - \frac{1}{9(w+5)} \right] dw = \int -\frac{1}{2} dt$ $\Rightarrow \frac{1}{9} \ln(w-4) - \frac{1}{9} \ln(w+5) = -\frac{1}{2}t + c$ $\Rightarrow \frac{1}{9} \ln \frac{w-4}{w+5} = -\frac{1}{2}t + c$ When $t = 0, w = 10 \Rightarrow c = \frac{1}{9} \ln \frac{6}{15} = \frac{1}{9} \ln \frac{2}{5}$ $\Rightarrow \ln \frac{w-4}{w+5} = -\frac{9}{2}t + \ln \frac{2}{5}$ $\Rightarrow \frac{w-4}{w+5} = e^{-\frac{9}{2}t + \ln \frac{2}{5}} = \frac{2}{5} e^{-\frac{9}{2}t} = 0.4e^{-4.5t} *$</p>	M1 M1 A1ft M1 M1 E1 [6]	separating variables substituting their partial fractions integrating correctly (condone absence of c) correctly evaluating c (at any stage) combining lns (at any stage) www
<p>(v) As $t \rightarrow \infty$ $e^{-4.5t} \rightarrow 0$ $\Rightarrow w - 4 \rightarrow 0$ So long term speed is 4 m s^{-1}.</p>	M1 A1 [2]	

Comprehension

1. (i)

2	1	3
3	2	1
1	3	2

B1
cao

(ii)

2	3	1
3	1	2
1	2	3

B1
cao

2. Dividing the grid up into four 2 x 2 blocks gives

1	2	3	4
3	1	4	2
2	4	1	3
4	3	2	1

Lines drawn on diagram or reference to 2 x 2 blocks. **M1**

One (or more) block does not contain all 4 of the symbols 1, 2, 3 and 4. **E1**

3.

1	2	3	4
4	3	1	2
2	1	4	3
3	4	2	1

Many possible answers Row 2 correct

Rest correct **B1**
B1

4. Either

4	2	3	1
		2	4
		4	2
2	4	1	3

Or

4	2	3	1
		2	4
		4	2
2	4	1	3

B2

5. In the top row there are 9 ways of allocating a symbol to the left cell, then 8 for the next, 7 for the next and so on down to 1 for the right cell, giving

M1

$$9 \times 8 \times 7 \times 6 \times 5 \times 4 \times 3 \times 2 \times 1 = 9! \text{ ways.}$$

E1

So there must be $9!$ times the number of ways of completing the rest of the puzzle.

6.

(i)

Block side length, b	Sudoku, $s \times s$	M
1	1×1	-
2	4×4	12
3	9×9	77
4	16×16	252
5	25×25	621

25×25 B1

77, 252 and 621 B1

(ii)

$$M = b^4 - 4$$

b^4 B1

- 4 B1

7.

- (i) There are neither 3s nor 5s among the givens. **M1**
So they are interchangeable and therefore there is no unique solution **E1**
- (ii) The missing symbols form a 3×3 embedded Latin square. **M1**
There is not a unique arrangement of the numbers 1, 2 and 3 in this square. **E1**

[18]

4754 Applications of Advanced Mathematics (C4)

General Comments

Many candidates found this paper was easier than that of last summer but more difficult than that in January this year. Section A included sufficient questions to challenge the good candidates but also many questions that were accessible to weaker candidates. Thus, there were very few low marks overall. The Comprehension scored highly with a number of straightforward numerical questions. Few, however, scored full marks here. Although candidates often appeared to have some understanding of the answers for the worded questions, they often did not give sufficient information to achieve the marks involved. The presentation was generally better than in previous years.

Comments on Individual Questions

Paper A

Section A

- 1) Many candidates scored only one mark from the three available here when attempting to add algebraic fractions. The majority of candidates knew and used the correct method for adding two fractions. However, only the minority factorised and cancelled their expression. In most cases the denominator $(x^2-4)(x-2)$ was used and the numerator $3x^2+2x-8$ was found but then candidates failed to continue. Only a small number realised that the simplest denominator was $(x+2)(x-2)$.
- 2) Most candidates correctly found the volume of revolution. Errors included failing to substitute the lower limit, failing to include the π in the term for the second limit and errors in integrating e^{2x} .
- 3) There were many completely correct solutions to this question. Some started badly by making an incorrect substitution for $\cos 2\theta$. $2\sin\theta\cos\theta$ and $1-\sin^2\theta$ were commonly seen. Those that substituted correctly were usually successful provided that they realised that their equation was a quadratic equation to be solved. Almost all candidates gave their answers in the required exact form in terms of π although some missed the solution $5\pi/6$.
- 4) There were some good, clear concise answers to this question, but they were in the minority. There was some very poor setting out of a logical argument. Candidates frequently failed to 'show that' sufficiently to achieve the mark for establishing the result. Common errors included $2\sec\theta = 1/2\cos\theta$ and $(3\sec\theta)^2=3\sec^2\theta$. Candidates need to improve their presentation of coherent arguments in 'proof' questions.
- 5) Almost all candidates obtained full marks on this question. Using the chain rule was the most common approach. The most frequent error was to substitute $u=5$ in part (ii). Occasionally a final answer of ± 6 was seen.

Report on the Units taken in June 2008

- 6) Most candidates used the Binomial expansion correctly in (i). Occasionally the powers of $\frac{1}{2}$ or -1 were used instead of $-\frac{1}{2}$. There were a few numerical errors in evaluating the third term. The commonest error, however, in (i) was the validity. This was often omitted and frequently wrong. Errors included, $|4x| < 1$, $|4x^2| \leq 1$, $-\frac{1}{2} \leq x \leq \frac{1}{2}$ and $\sqrt{-1/4} < x < \sqrt{1/4}$. It was disappointing, although not penalised, to find so many candidates failing to simplify $\sqrt{1/4}$ to $1/2$. Most candidates correctly used their expression from (i) in (ii) although weaker candidates failed to recognise the usefulness or relevance of part (i). A few tried to expand $(1-x^2)$ in (ii) using the Binomial expansion again.
- 7) Many candidates approached the solution to this question by learning the process rather than from first principles often leading to $\tan \alpha = \sqrt{3}$ instead of $1/\sqrt{3}$. Sign errors, commonly $-1 = R \sin \alpha$ were seen and again, disappointingly, $\sqrt{4}$ left unresolved was often seen for R - although most candidates did obtain $R=2$. The final part was usually either completely correct or omitted.

Section B

- 8) (i) A wide variety of methods were seen. These included substituting the co-ordinates of the points in the equation of the plane, using a vector product and a combination of substituting points and the scalar product of vectors in the plane with the normal vector. Finding the Cartesian equation of the plane from the vector equation was also often used. Many candidates (even the most able students) failed to realise that more than one point substituted was needed and also failed to realise that one scalar product, or two, alone is insufficient to verify the Cartesian equation of the plane.
- (ii) This was usually successful and full working was shown. The last part was sometimes again found from the vector equation of the plane. Some gave the final part as $2x-y+20z=0$ or $2x-y+20z=800$.
- (iii) The scalar product was usually correct provided the correct vectors were used although there were numerical errors.
- (iv) The correct vector equation was usually given although ' $r =$ ' was often omitted. The final answer was also often found but some failed to realise that they needed to substitute into the equation of the plane. A frequent error was ' $413+413\lambda=0, \lambda=1$ '.
- 9) (i) Most candidates separated the variables and attempted to integrate. Most did not include a constant. Common incorrect answers being $v = \pm 20e^{-\frac{1}{2}t}, 10e^{-\frac{1}{2}t}$ and $5e^{-\frac{1}{2}t}$.
- (ii) For good candidates who had found 'c' in (i), (ii) was usually successful. Many failed to realise that $e^{-\frac{1}{2}t} \rightarrow 0$, choosing ∞ or 1 instead. Some substituted a large value for t which was condoned in (ii) but not in (v).
- (iii) The partial fractions were almost always correct.
- (iv) Some candidates made a poor start here, failing to separate the variables and only working with their partial fractions from (iii). For those that separated the variables correctly, their initial integration was usually correct and they combined their logarithms correctly but for those that included a constant it was rarely found successfully. The correct final answer was given and often appeared without derivation. For those evaluating a constant a **frequent error**, as in the past, was to separate $\exp(-4.5t+c)$ as $\exp(-4.5t) + \exp c$.
- (v) Few found that $w \rightarrow 4$ as $t \rightarrow \infty$. $w \rightarrow 0$ was fairly common.

Paper B - The Comprehension

- 1) The tables were almost always filled in correctly.
- 2) Many candidates failed to make it clear that they were discussing 2x2 blocks in their explanations. Some referred to 3x3 blocks or blocks in general or said that a Sudoku had to be 9x9. For those that did indicate 2x2 blocks, they usually gave the required reason for the Latin Square not being a Sudoku puzzle which is because there were repeated entries in the individual blocks.
- 3) This table was usually completed correctly although some gave Fig. 10.
- 4) This was usually correct.
- 5) This was not well done. Some said that because there were 9 squares it must be 9! rather than explaining this was the number of ways to fill in a row of 9. Some said if 3x3 was 3! And 4x4 was 4! then this must be 9!. Others failed to explain that the 9! would need to be multiplied by the number of ways for the rest of the grid to get the total number.
- 6) This was often completely correct. Most found 25x25 correctly but there were errors in the second column. In (ii) common errors were $M=b^4 - b^2$ and using s instead of b .
- 7)
 - (i) Those that realised that all the 3s and 5s were missing from the givens were usually successful. Others missed the point and said there was no unique solution because there were less than 77 givens.
 - (ii) There were many confused explanations here often referring, again, to the total number of givens rather than discussions about the numbers 1,2 and 3 forming an embedded square with 12 different solutions possible.

Grade Thresholds

June 2008 Examination Series

Unit Threshold Marks

Unit		Maximum mark	A	B	C	D	E	U
All units	UMS	100	80	70	60	50	40	0
4754	Raw	90	75	67	59	51	43	0

ADVANCED GCE

MATHEMATICS (MEI)

Applications of Advanced Mathematics (C4) Paper B: Comprehension

4754B

Candidates answer on the question paper

OCR Supplied Materials:

- Insert (inserted)
- MEI Examination Formulae and Tables (MF2)

Other Materials Required:

- Rough paper

Tuesday 13 January 2009
Morning

Duration: Up to 1 hour



Candidate Forename		Candidate Surname	
Centre Number			
Candidate Number			

INSTRUCTIONS TO CANDIDATES

- Write your name clearly in capital letters, your Centre Number and Candidate Number in the boxes above.
- Use black ink. Pencil may be used for graphs and diagrams only.
- Read each question carefully and make sure that you know what you have to do before starting your answer.
- Answer **all** the questions.
- Do **not** write in the bar codes.
- Write your answer to each question in the space provided, however additional paper may be used if necessary.
- You are permitted to use a graphical calculator in this paper.
- Final answers should be given to a degree of accuracy appropriate to the context.

INFORMATION FOR CANDIDATES

- The number of marks is given in brackets [] at the end of each question or part question.
- The insert contains the text for use with the questions.
- You may find it helpful to make notes and do some calculations as you read the passage.
- You are **not** required to hand in these notes with your question paper.
- You are advised that an answer may receive **no marks** unless you show sufficient detail of the working to indicate that a correct method is being used.
- The total number of marks for this paper is **18**.
- This document consists of **4** pages. Any blank pages are indicated.

Examiner's Use Only:	
1	
2	
3	
4	
5	
6	
Total	

1 Show how the value $d = 8$ on line 32 is obtained. [2]

.....
.....
.....

2 Using the information given on lines 38 and 39, derive equation (1). [3]

.....
.....
.....
.....

3 On lines 43 and 44 it is suggested that the volume of fuel in the tank in Figs. 2.1 and 2.2 could be calculated using the values of h and θ .

Calculate the volume of fuel in the case where $h = 5$ and $\theta = 30^\circ$. [3]

.....
.....
.....
.....

- 4 A fuel tank in the shape of a cuboid is shown below.

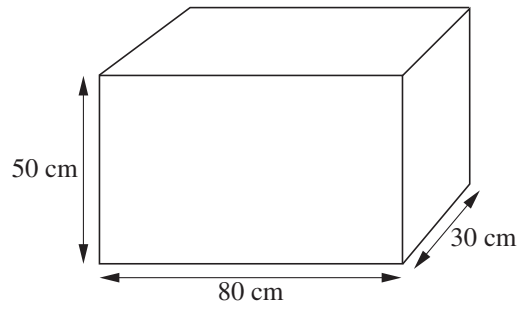

It is partly filled with fuel and inclined at an angle to the horizontal. The side view is shown below.

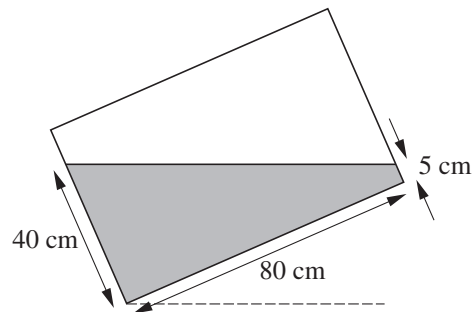

Calculate the volume, in litres, of fuel in the tank.

[3]

.....

.....

.....

5 (i) Explain clearly how the equation on line 72 can be simplified to give the quadratic equation on line 74. [1]

.....

.....

.....

.....

(ii) In line 76 only one root of the quadratic equation is given. Find the other root and explain why it is not relevant in the context of this problem. [3]

.....

.....

.....

.....

6 On line 90 it is stated that if $H = h = 10$ then equation (4) gives a volume of 37.5 litres. Use equations (3) and (4) to show how this volume is derived. [3]

.....

.....

.....

.....

.....

.....



Permission to reproduce items where third-party owned material protected by copyright is included has been sought and cleared where possible. Every reasonable effort has been made by the publisher (OCR) to trace copyright holders, but if any items requiring clearance have unwittingly been included, the publisher will be pleased to make amends at the earliest possible opportunity.

OCR is part of the Cambridge Assessment Group. Cambridge Assessment is the brand name of University of Cambridge Local Examinations Syndicate (UCLES), which is itself a department of the University of Cambridge.

ADVANCED GCE

MATHEMATICS (MEI)

Applications of Advanced Mathematics (C4) Paper B: Comprehension

INSERT

4754B

Tuesday 13 January 2009
Morning

Duration: Up to 1 hour



INSTRUCTIONS TO CANDIDATES

- This insert contains the text for use with the questions.

INFORMATION FOR CANDIDATES

- This document consists of **8** pages. Any blank pages are indicated.

Measuring the volume of fuel in a tank

Introduction

In many cars, aeroplanes and other vehicles, there is a display which provides information about various aspects of the engine system. This includes, for example, the temperature of the engine, the rate of fuel consumption and the volume of fuel remaining in the tank. This information is generated from measurements made by electronic sensors. 5

This article is concerned with the mathematics involved in calculating the volume of fuel in a fuel tank using measurements made by sensors in the tank.

When positioning sensors in a fuel tank, there are two major factors to consider. These are the shape of the tank and the possible orientations to the horizontal that the tank might experience during motion. 10

The shapes of fuel tanks in aircraft wings are determined by the shape of the wings. Consequently, aircraft fuel tanks have complex shapes and advanced mathematical techniques are required in order to calculate the volume of fuel in the tanks. In contrast, the fuel tanks in cars are not tightly constrained by the shape of the car and so can have relatively simple shapes. 15

Aircraft often fly at extreme angles to the horizontal. The sensors in the fuel tanks need to be positioned in such a way that they can always give meaningful measurements which can be used to calculate the volume of fuel in the tank.

Two shapes of tanks are considered in this article: a cylindrical tank, as an approximation to the fuel tanks used in some cars, and a trapezoidal tank, as an approximation to those used in some aircraft. 20

Cylindrical tanks

On level ground

Fig. 1 shows a vertical cylindrical tank with radius 20 cm and height 50 cm containing fuel to a depth of d cm.

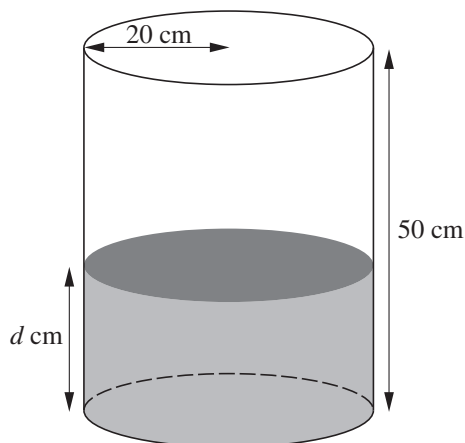

Fig. 1

The relationship between the depth, d cm, and volume, V litres, of the fuel is given by the formula 25

$$V = \frac{1}{1000} \times \pi \times 20^2 \times d.$$

For a cylindrical tank in this position, a sensor inside the tank would need to measure only the distance between the surface of the fuel and the top of the tank in order to calculate the volume of fuel.

The system could be set so that, if the volume of fuel drops below a certain amount, a warning light comes on. For example, if the critical volume is set as 10 litres, the warning light comes on when $d = 8$. 30

On a shallow incline

Figs. 2.1 and 2.2 (a vertical section) show the tank with its base inclined at an angle θ to the horizontal, where $\tan \theta = \frac{H-h}{40}$. PQ represents the surface of the fuel; PP' and Q'Q are parallel to the base of the tank. 35

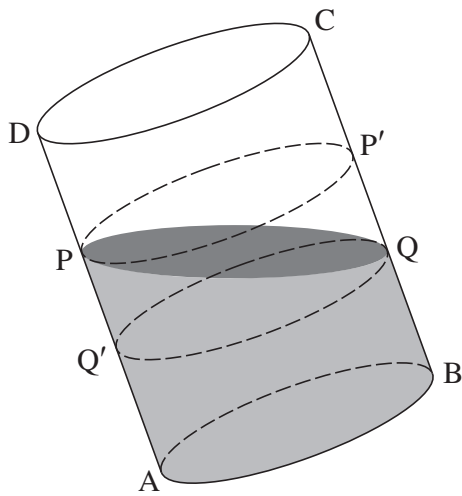

Fig. 2.1

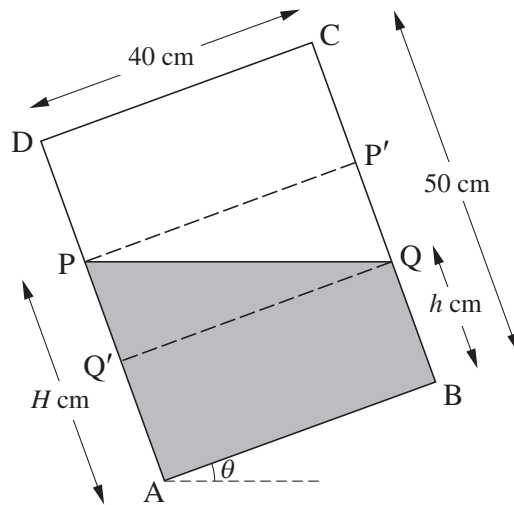

Fig. 2.2

The part of the tank between PP' and Q'Q is divided into two congruent halves by the surface of the fuel. Therefore the volume of the fuel in the tank can be calculated by adding the volume of the cylinder ABQQ' to half of the volume of the cylinder Q'QP'P. It follows that the volume, V litres, is given by 40

$$V = \frac{1}{5}\pi(H + h). \quad (1)$$

Two sensors could measure the distances DP and CQ. These measurements could then be used to calculate the volume of fuel in the tank. Alternatively, one of these sensors could be used together with a different sensor which measures θ to calculate this volume.

Table 3 shows some possible values of h , H and θ for which this tank is three-quarters full. Notice that when $\theta = 32.0^\circ$, the surface of the fuel touches the top of the tank at D. 45

h	37.5	35	32.5	30	27.5	25
H	37.5	40	42.5	45	47.5	50
θ	0°	7.1°	14.0°	20.6°	26.6°	32.0°

Table 3

In this case, and for any other volume of fuel in the tank, there is an angle of inclination beyond which equation (1) will no longer apply.

On a steep incline

Fig. 4 shows a vertical section of the tank inclined at a steep angle to the horizontal.

50

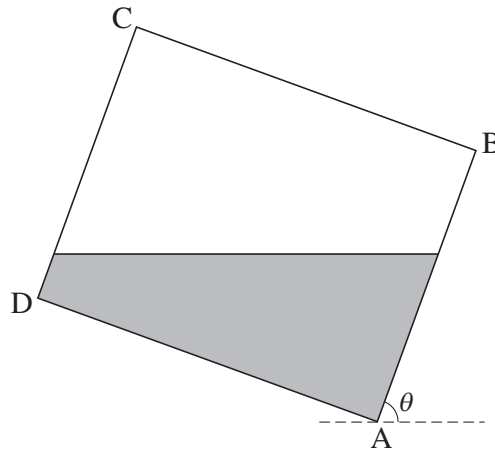
**Fig. 4**

Sensors designed to measure the distance of the surface of the fuel from D along DA and from C along CB would no longer provide useful information.

This is not a serious issue for cars with such tanks since the steepest roads have an angle of inclination of only about 15° .

Fuel tanks in aircraft

55

In aircraft, the shapes of fuel tanks are determined by the shape of the wing. Calculating the volume of fuel in such tanks requires advanced modelling and computational techniques.

A trapezoidal tank is considered below as an approximation to an aircraft fuel tank. The calculations give an indication of the way in which the volumes of such shapes are calculated.

Trapezoidal tanks

60

On level ground

Fig. 5 shows a trapezoidal tank; it is a prism with an isosceles trapezium cross-section.

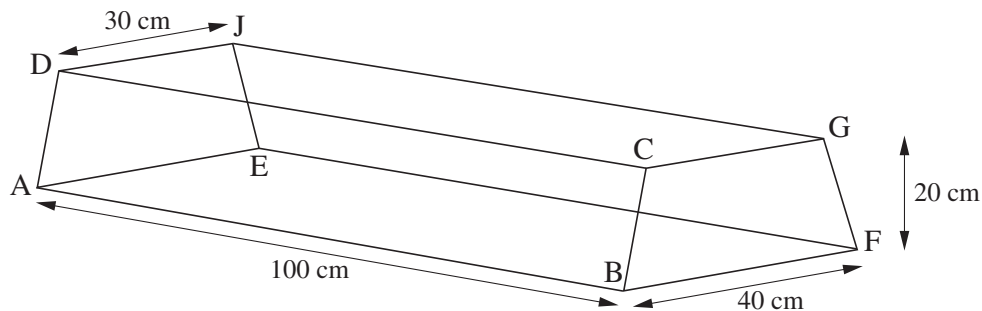
**Fig. 5**

The capacity of this tank is

$$\frac{1}{2} \times 20 \times (30 + 40) \times 100 \text{ cm}^3 = 70 \text{ litres.}$$

Fig. 6 shows the cross-section of the tank when it contains fuel to a depth of y cm.

65

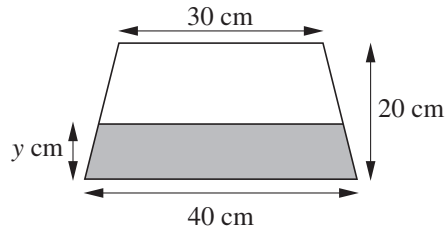

Fig. 6

The shaded area, $A \text{ cm}^2$, in Fig. 6 is given by

$$A = \frac{1}{2} \times y \times \left(80 - \frac{y}{2}\right).$$

The volume, V litres, of fuel in the tank is given by

$$V = \frac{1}{2} \times y \times \left(80 - \frac{y}{2}\right) \times \frac{1}{10}. \quad (2)$$

A sensor in this tank could be set so that, if the volume drops to 10 litres, a warning light comes on. This happens when y satisfies the equation

70

$$\frac{1}{2} \times y \times \left(80 - \frac{y}{2}\right) \times \frac{1}{10} = 10.$$

This equation simplifies to

$$y^2 - 160y + 400 = 0.$$

By solving this equation, it can be shown that the warning light comes on when the depth of the fuel drops to 2.54 cm.

75

On a shallow incline

The tank in Fig. 5, containing fuel, is now tilted about the edge AE. Fig. 7 shows a vertical section of the tank.

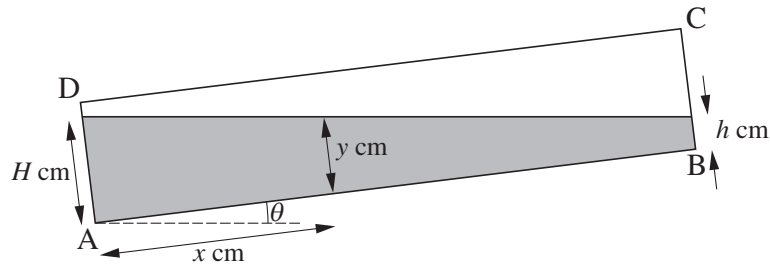

Fig. 7

The two ends of the tank and a cross-section parallel to them are shown in Fig. 8. The distance of the cross-section from the end AEJD is x cm, where $0 \leq x \leq 100$. 80

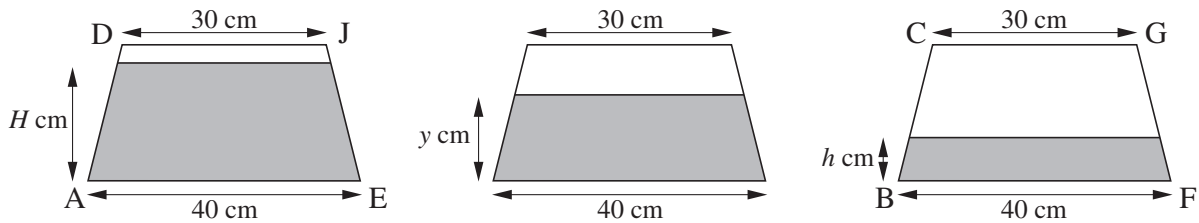

Fig. 8

The relationship between y , as shown in Figs. 7 and 8, and x is given by

$$y = H - \frac{H-h}{100}x. \quad (3)$$

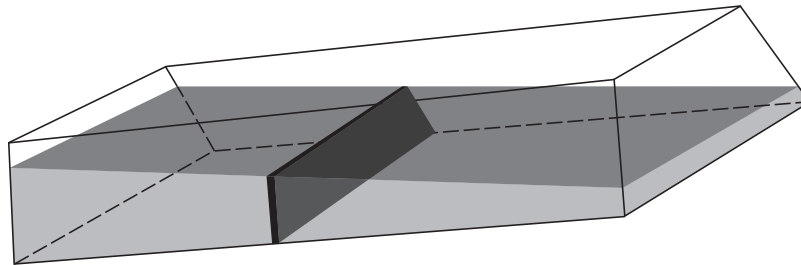

Fig. 9

To calculate the volume of fuel in the tank in Fig. 7, you can think of the region occupied by the fuel as being made up of a large number of thin trapezoidal prisms like the one shown in Fig. 9. It can then be shown that the volume, V litres, of fuel is given by 85

$$V = \frac{1}{1000} \int_0^{100} \frac{y}{2} \left(80 - \frac{y}{2} \right) dx. \quad (4)$$

For example, if sensors indicate that $H = 20$ and $h = 0$, then equation (3) gives $y = 20 - \frac{1}{5}x$. Equation (4) then gives a volume of $36\frac{2}{3}$ litres.

Similarly, if $H = h = 10$, then equation (4) gives a volume of 37.5 litres. Since in this case the tank is on level ground, the volume could have been found using equation (2). 90

On a steep incline

Fig. 10 shows a vertical section of the tank at a steeper angle of inclination to the horizontal.

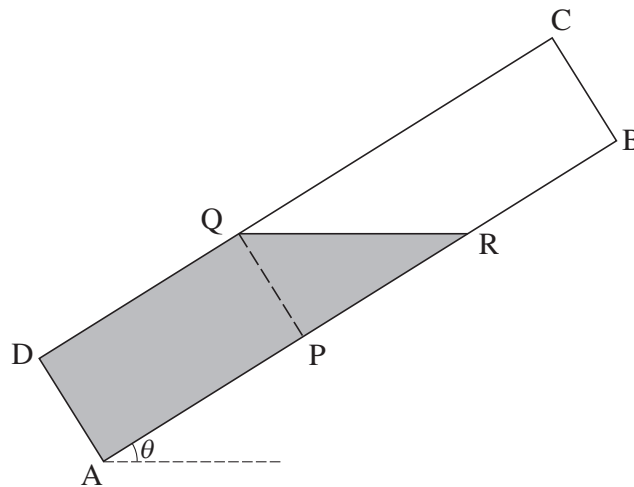

Fig. 10

The techniques required to calculate the volume indicated in Fig. 10 are similar to those used in deriving equation (4). Sensors measure the distances BR and CQ which are needed in order to calculate this volume.

95

In conclusion

Sensors in aircraft do much more than measure the volume of fuel in the tank. When designing and testing tanks for use in aircraft, sensors provide information about the movement of fuel in the tank. It is crucially important to ensure that, at all times, fuel is being sucked from the tanks into the engines. Sensors allow the designers and engineers to ensure that the shapes of the tanks meet these crucial requirements.

100

ADVANCED GCE

MATHEMATICS (MEI)

Applications of Advanced Mathematics (C4) Paper B: Comprehension

4754B

Candidates answer on the question paper

OCR Supplied Materials:

- Insert (inserted)
- MEI Examination Formulae and Tables (MF2)

Other Materials Required:

- Rough paper

Monday 1 June 2009
Morning

Duration: Up to 1 hour



Candidate Forename		Candidate Surname	
Centre Number		Candidate Number	

INSTRUCTIONS TO CANDIDATES

- Write your name clearly in capital letters, your Centre Number and Candidate Number in the boxes above.
- Use black ink. Pencil may be used for graphs and diagrams only.
- Read each question carefully and make sure that you know what you have to do before starting your answer.
- Answer **all** the questions.
- Do **not** write in the bar codes.
- Write your answer to each question in the space provided, however additional paper may be used if necessary.
- You are permitted to use a graphical calculator in this paper.
- Final answers should be given to a degree of accuracy appropriate to the context.

INFORMATION FOR CANDIDATES

- The number of marks is given in brackets [] at the end of each question or part question.
- The insert contains the text for use with the questions.
- You may find it helpful to make notes and do some calculations as you read the passage.
- You are **not** required to hand in these notes with your question paper.
- You are advised that an answer may receive **no marks** unless you show sufficient detail of the working to indicate that a correct method is being used.
- The total number of marks for this paper is **18**.
- This document consists of **4** pages. Any blank pages are indicated.

Examiner's Use Only:	
1	
2	
3	
4	
5	
6	
7	
Total	

1 On lines 90 and 91, the article says “The average score for each player works out to be 0.25 points per round”. Derive this figure. [2]

.....
.....
.....

2 Line 47 gives the inequality $b > c > d > w$.

Interpret each of the following inequalities in the context of the example from the 1st World War.

(i) $b > w$ [1]

(ii) $c > d$ [1]

(i)
.....
.....

(ii)
.....
.....

3 Table 3 illustrates a possible game where you always co-operate. In lines 98 and 99 the article says “Clearly the longer the game goes on the closer your average score approaches -2 points per round and that of your opponent approaches 3.”

How many rounds have you played when your average score is -1.999 ? [3]

.....
.....
.....
.....
.....

4 A Prisoner's Dilemma game is proposed in which

$$b = 6, c = 1, d = -1 \text{ and } w = -3.$$

Using the information in the article, state whether these values would allow long-term co-operation to evolve. Justify your answer. [2]

.....

.....

.....

5 In a Prisoner's Dilemma game both players keep strictly to a Tit-for-tat strategy. You start with C and your opponent starts with D. The scoring system of $b = 3, c = 1, d = -1$ and $w = -2$ is used.

(i) This table shows the first 8 out of many rounds. Complete the table. [3]

Round	You	Opponent	Your score	Opponent's score
1	C	D		
2				
3				
4				
5				
6				
7				
8				
...

(ii) Find your average score per round in the long run. [2]

.....

.....

.....

6 In the article, the scoring system is $b = 3$, $c = 1$, $d = -1$ and $w = -2$.

In Axelrod's experiment, negative numbers were avoided by taking $b = 5$, $c = 3$, $d = 1$ and $w = 0$.

State the effect this change would have on

(i) the players' scores, [1]

(ii) who wins. [1]

(i)
.....

(ii)
.....

7 Two companies, X and Y, are the only sellers of ice cream on an island. They both have a market share of about 50%. Although their ice cream is much the same, both companies spend a lot of money on advertising.

(i) What agreement might the companies reach if they decide to co-operate? [1]

.....
.....

(ii) What advantage would a company hope to gain by 'defecting' from this agreement? [1]

.....
.....



Copyright Information

OCR is committed to seeking permission to reproduce all third-party content that it uses in its assessment materials. OCR has attempted to identify and contact all copyright holders whose work is used in this paper. To avoid the issue of disclosure of answer-related information to candidates, all copyright acknowledgements are reproduced in the OCR Copyright Acknowledgements Booklet. This is produced for each series of examinations, is given to all schools that receive assessment material and is freely available to download from our public website (www.ocr.org.uk) after the live examination series.

If OCR has unwittingly failed to correctly acknowledge or clear any third-party content in this assessment material, OCR will be happy to correct its mistake at the earliest possible opportunity.

For queries or further information please contact the Copyright Team, First Floor, 9 Hills Road, Cambridge CB2 1PB.

OCR is part of the Cambridge Assessment Group; Cambridge Assessment is the brand name of University of Cambridge Local Examinations Syndicate (UCLES), which is itself a department of the University of Cambridge.

ADVANCED GCE

MATHEMATICS (MEI)

Applications of Advanced Mathematics (C4) Paper B: Comprehension

INSERT

4754B

Monday 1 June 2009
Morning

Duration: Up to 1 hour



INSTRUCTIONS TO CANDIDATES

- This insert contains the text for use with the questions.

INFORMATION FOR CANDIDATES

- This document consists of **8** pages. Any blank pages are indicated.

The Prisoner's Dilemma

Introduction

During the 1st World War a curious sort of truce often occurred between the two sides. Between fierce battles there were long periods when nothing much happened; the soldiers were living in trenches quite close to the enemy and, without any conversations taking place, understandings often arose that they would not shoot at each other. A British officer visiting the front line was horrified by what he saw. 5

I was astonished to observe German soldiers walking about within rifle range behind their own line. Our men appeared to take no notice. I privately made up my mind to do away with that sort of thing ... ; such things should not be allowed. These people evidently did not know there was a war on. Both sides apparently believed in the policy of 'live and let live'. 10

This did not mean that the soldiers on the two sides had become friends. They did not know each other and they certainly would shoot to kill when the next major battle occurred, but in the meantime co-operation was a better policy.

How could such behaviour arise spontaneously? This article looks at a mathematical model that describes it and allows it to be simulated. 15

What happened across the trenches of the 1st World War is just one example of a general situation in which opposing groups, between whom there is no mutual trust or friendship, nonetheless find it beneficial to co-operate. Other examples include an arms race between two countries and commercial competition between companies. Another situation arises when each of two suspects is offered a lighter prison sentence in exchange for giving information against the other; this has given rise to the general name 'The Prisoner's Dilemma' for all such situations. 20

Modelling the situation

Imagine the situation in the 1st World War. On any occasion the soldiers on each side had two options. 25

- They could 'co-operate' with the other side by not shooting. (Option C)
- They could 'defect' by breaking the agreement and shooting. (Option D)

So between the two sides, there were four possibilities as shown in Table 1.

	Side 2 co-operates	Side 2 defects
Side 1 co-operates	C C	C D
Side 1 defects	D C	D D

Table 1

The 'benefits' and 'costs' to each side of these different situations may be described as follows.

- In the situation C C, the two sides co-operate and they both benefit; no one gets shot (and so killed or injured). 30
- In the situation D D, both sides defect and shoot at each other. There is a cost to both sides because some of their soldiers get shot.

- In the situation DC, Side 1 unexpectedly defects by breaking the agreement and shooting some of the enemy soldiers. This is of short-term benefit to Side 1 by advancing the war effort; in contrast, Side 2 pays the cost of losing some soldiers. 35
- The fourth situation CD is the mirror image of DC. In this case there is a cost to Side 1 because some of their soldiers are shot, and there is a short-term benefit to Side 2.

There are thus four possible levels of benefit that may be modelled as follows.

Both sides co-operate (CC). Each benefits by c units. 40

Both sides defect (DD). Each benefits by d units, where d is negative.

One side co-operates and the other defects (DC or CD):

the defecting side benefits by b units from breaking the agreement and the co-operating side, for whom this is the worst possible outcome, benefits by w units, where w is negative. 45

The situation being modelled means that

$$b > c > d > w.$$

Turning the model into a game

This model has been the subject of extensive study, using the technique of turning it into a game. There are two players and, at each turn, they declare C (co-operate) or D (defect) at the same time as each other. In this article the various benefits are set as the following values, although other values are commonly used. 50

When both players co-operate (CC), each scores 1 point: $c = 1$.

When both players defect (DD), each scores -1 point: $d = -1$.

When one player co-operates and the other defects (DC or CD), the player who co-operates scores -2 points: $w = -2$. The defecting player benefits by 3 points: $b = 3$. 55

This raises two questions.

- What is a good strategy for the game?
- What, if anything, does the game tell us about human behaviour?

Playing a single round 60

Imagine that you are one of the two players. Start with the case when there is only a single round of the game. It is possible to apply simple logic to this situation. Remember that both players declare at the same moment.

The other player is going to declare either C or D.

Take first the case when the other player declares C. 65

If you declare C, you score 1 point.

If you declare D, you score 3 points.

So you are better to declare D.

Now take the case when the other player declares D.

If you declare C, you score -2 points.

If you declare D, you score -1 point.

So again you are better off to declare D.

70

So, whatever the other player declares, your better option is D.

However, the other player can be expected to apply the same logic and so also to declare D. So the outcome is predictable as being DD, worth -1 point to each player. This seems paradoxical when this is not the best possible outcome for either player, since CC would give both players a score of 1 point.

75

This result does, however, make sense in terms of human behaviour if neither party expects to meet the other again. Soldiers might shoot to kill in a one-off war-time encounter, and in a single commercial transaction both parties might seek to make as much money out of the other as possible.

80

Co-operation becomes more likely when the two parties expect to have a long-term relationship.

A large number of rounds

Now suppose that you are playing the Prisoner's Dilemma game with a very large number of rounds, with no end in sight. What is a good strategy ?

Random choice

85

One possible strategy is to choose C and D at random, both with probability $\frac{1}{2}$. Suppose that both players do this independently. Then on any move there are 4 possible outcomes: CC, CD, DC and DD. The scores for these are shown in Table 2.

Outcome	C	C	C	D	D	C	D	D
Scores	1	1	-2	3	3	-2	-1	-1

Table 2

These four outcomes are all equally likely so each has a probability of occurring on any move of $\frac{1}{4}$; on average each will occur once every 4 rounds. The average score for each player works out to be 0.25 points per round.

90

Constant choice

Another simple strategy is to make the same choice, either C or D, on every round. The problem is that your opponent will soon realise what you are doing and will seek to exploit it. Table 3 shows a case when you always co-operate. At some point, in this example on the third round, your opponent will defect and will continue to do so once it is clear that you will continue to co-operate. The game settles down with you scoring -2 points every round and your opponent 3 points.

95

Round	You	Opponent	Your score	Opponent's score
1	C	C	1	1
2	C	C	1	1
3	C	D	-2	3
4	C	D	-2	3
5	C	D	-2	3
6	C	D	-2	3
7	C	D	-2	3
8	C	D	-2	3
9	C	D	-2	3
10	C	D	-2	3
...

Table 3

Clearly the longer the game goes on the closer your average score approaches -2 points per round and that of your opponent approaches 3.

Table 4 shows a possible game when you always defect.

100

Round	You	Opponent	Your score	Opponent's score
1	D	C	3	-2
2	D	C	3	-2
3	D	D	-1	-1
4	D	D	-1	-1
5	D	C	3	-2
6	D	D	-1	-1
7	D	D	-1	-1
8	D	D	-1	-1
9	D	D	-1	-1
10	D	D	-1	-1
...

Table 4

After some attempts at co-operation your opponent realises that the best strategy playing against you is also to defect. Once the game settles down you both score -1 point at each round.

Both of these two fixed-choice strategies result in your obtaining a lower average score per round than you would have done by choosing at random. They illustrate the fact that your opponent will try to learn from your play and then to benefit from it. Even though you do not talk to your opponent, communication is still taking place through your actions, as happened between the trenches of the 1st World War.

105

Tit-for-tat

An alternative strategy to adopt is 'Tit-for-tat'. In this, you always do the same thing as your opponent did last time. So the first few rounds of a game might be as in Table 5.

110

Round	You	Opponent	Your score	Opponent's score
1	C	C	1	1
2	C	C	1	1
3	C	C	1	1
4	C	D	-2	3
5	D	D	-1	-1
6	D	C	3	-2
7	C	C	1	1
8	C	D	-2	3
9	D	C	3	-2
10	C	C	1	1
...

Table 5

In this example, although you both start off co-operating scoring 1 point per round, in Round 4 your opponent defects and so scores 3 points on that round to your -2. However, you respond immediately by defecting on Round 5 and you continue to defect until the round after your opponent next co-operates; thus your opponent co-operates on Round 6 and you co-operate again on Round 7.

Over Rounds 4, 5 and 6 your opponent scores $3 + (-1) + (-2) = 0$ points and this is less than the 3 points that would have resulted from co-operating for those three rounds.

115

In Round 8 your opponent tests you by defecting again and you respond immediately by defecting in Round 9. By Round 10 you are back to mutual co-operation but this short-term defection has cost your opponent 1 point.

Once your Tit-for-tat strategy is clear, the only sensible thing for your opponent to do is to co-operate at every round, leading to a long-term average score of 1 point per round for both of you.

120

Thus Tit-for-tat is a strategy which allows long-term co-operation to evolve. It was used strictly in the 1st World War. Both sides knew that if they fired at the other, there would be instant retaliation.

The example in Table 5 illustrates an important feature of the scoring system for the Prisoner's Dilemma game. In Rounds 8 and 9, your opponent scored $3 + (-2) = 1$ point; since this was less than the $2 \times 1 = 2$ points available for continued co-operation, defection did not pay. The benefits b , c , d and w were assigned the values 3, 1, -1 and -2 respectively, but these are not the only possible values that obey the inequality on line 47, $b > c > d > w$. If, for example, b were given the value 10 and the other values remained the same, then a short-term defection would be a profitable thing to do.

125

130

So for long-term co-operation to be the best option, the following further condition must be fulfilled.

$$b + w < 2c.$$

This inequality may be written as $b < 2c - w$ and may be interpreted as saying that long-term co-operation is only possible if the benefit from defection, b , is not too great.

Competitions for the best strategy

135

Because the Prisoner's Dilemma can be used to model a great variety of situations, it has attracted a large amount of academic interest; many research papers have been written about it. In 1984 Robert Axelrod published *The Evolution of Co-operation*; it has now become a classic book on the subject. In this he reported on a large computer-based competition to determine the best strategy. There were 62 entries, each in the form of a computer program, from a wide variety of sources. Each of them played all the others over 200 rounds, and the whole exercise was carried out 5 times. The winning strategy was Tit-for-tat.

140

Axelrod analysed the most successful strategies and found they all had certain characteristics, which he described in the following terms.

- They were all *nice*; that is they would not defect before the opponent did.
- They would always *retaliate* when an opponent defected.
- They were *forgiving*, returning to co-operation once the opponent ceased to defect.
- They were *non-jealous*, seeking to maximise their own benefit rather than to reduce that of their opponents.

145

If this sounds rather idealistic, it is not. It is a statement that a selfish individual acting entirely out of self-interest will nonetheless behave in ways that are generally thought to be good.

150

In conclusion

This article introduces the Prisoner's Dilemma game, but it only scratches the surface. The game itself can be refined in various ways but there is much more that can be learnt from it even in its simplest form.

155

It is said that one of the challenges for mathematics is to develop techniques for studying and predicting human behaviour. The Prisoner's Dilemma provides one example of how using a suitable game may allow this to be done.

ADVANCED GCE

MATHEMATICS (MEI)

Applications of Advanced Mathematics (C4) Paper B: Comprehension

4754B

Candidates answer on the Question Paper

OCR Supplied Materials:

- Insert (inserted)
- MEI Examination Formulae and Tables (MF2)

Other Materials Required:

- Rough paper

**Friday 15 January 2010
Afternoon**

Duration: Up to 1 hour



Candidate Forename		Candidate Surname	
--------------------	--	-------------------	--

Centre Number						Candidate Number				
---------------	--	--	--	--	--	------------------	--	--	--	--

INSTRUCTIONS TO CANDIDATES

- Write your name clearly in capital letters, your Centre Number and Candidate Number in the boxes above.
- Use black ink. Pencil may be used for graphs and diagrams only.
- Read each question carefully and make sure that you know what you have to do before starting your answer.
- Answer **all** the questions.
- Do **not** write in the bar codes.
- Write your answer to each question in the space provided, however additional paper may be used if necessary.
- You are permitted to use a graphical calculator in this paper.
- Final answers should be given to a degree of accuracy appropriate to the context.

INFORMATION FOR CANDIDATES

- The number of marks is given in brackets [] at the end of each question or part question.
- The insert contains the text for use with the questions.
- You may find it helpful to make notes and do some calculations as you read the passage.
- You are **not** required to hand in these notes with your question paper.
- You are advised that an answer may receive **no marks** unless you show sufficient detail of the working to indicate that a correct method is being used.
- The total number of marks for this paper is **18**.
- This document consists of **4** pages. Any blank pages are indicated.

Examiner's Use Only:	
1	
2	
3	
4	
5	
6	
7	
8	
Total	

- 1 A Caesar cipher uses a shift of 11 places. Using lines 36 and 37, write down the shift for the decoding cipher in this case. [1]

.....

- 2 Using lines 143 to 146, write out the first 16 letters of the plaintext message corresponding to the ciphertext message on lines 97 to 101. [1]

.....

.....

.....

- 3 Table 4 shows an encoding cipher. Complete the table below to show part of the decoding cipher. [2]

Ciphertext	<i>A</i>	<i>B</i>	<i>C</i>	<i>D</i>	<i>E</i>
Plaintext					

- 4 Line 137 says ‘in string S_2 , the encoded form of the letter *A* is *N*’. Give two reasons why this is a sensible suggestion. [2]

.....

.....

.....

.....

- 5 Lines 105 and 106 say ‘Taken together, these two shifts suggest that the keyword has length 2 or 4’. Explain why this is the case. [2]

.....

.....

.....

6 Lines 107 and 108 say ‘a keyword of length 2 would form a less secure cipher than one of length 4’. Explain why this is true. [2]

.....
.....
.....

7 A long passage is encoded using the Vigenère cipher with keyword **ODE**. Write down the different ways in which the plaintext word AND could appear in the ciphertext. [2]

.....

8 A passage of plaintext is encoded by using the Caesar cipher corresponding to a shift of 2 places followed by the Vigenère cipher with keyword **ODE**.

(i) The first letter in the plaintext passage is F. Show that the first letter in the transmitted text is V. [1]

.....
.....

(ii) The first four letters in the transmitted text are *VFIU*. What are the first four letters in the plaintext passage? [3]

.....
.....
.....
.....

(iii) The 800th letter in the transmitted text is *W*. What is the 800th letter in the plaintext passage? [2]

.....
.....
.....
.....

Cipher Systems

Introduction

Imagine you want to send a written message to a friend containing confidential information. You are keen to ensure that the information remains private but you are aware that other people might try to intercept the message before it reaches its destination. Therefore it is necessary to use some form of code, or *cipher*, known to you and your friend, so that anybody who intercepts the message will find it difficult to extract the information. 5

You use an encoding cipher to encode your message (called the *plaintext*) and then transmit the resulting message (called the *ciphertext*). Your friend will then decode the message using an appropriate decoding cipher. This *cipher system* is illustrated in Fig. 1. 10

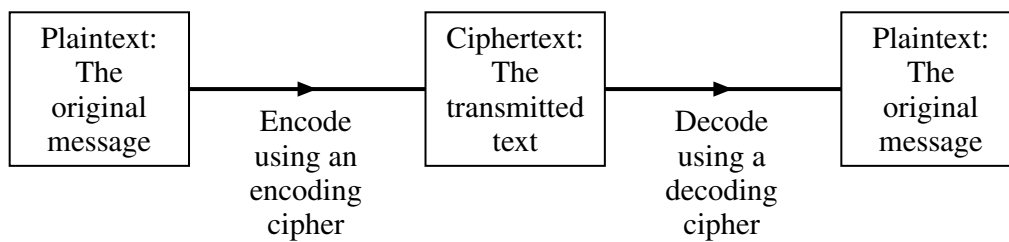

Fig. 1

What is the most appropriate cipher system to use so that you can send and receive messages quickly and cheaply, whilst minimising the risk that an interceptor will be able to decode the ciphertext?

This has been an important question for at least two thousand years, since messages were written on the shaved heads of messengers who would then wait until their hair grew back before setting off on journeys to the intended recipients. More sophisticated cipher systems have been developed and some of these are described in this article. The methods are not necessarily representative of those used in practice today, but highlight some of the weaknesses which need to be avoided when trying to design a secure cipher system. 15

Caesar cipher

This is the most basic form of cipher. In a Caesar cipher, each letter in the message is replaced by the letter a fixed number of places further on in the alphabet to give the text to transmit. 20

For example, Table 2 shows the Caesar cipher corresponding to a shift of the alphabet by 21 places.

Plaintext	A	B	C	D	E	F	G	H	I	J	K	L	M	N	O	P	Q	R	S	T	U	V	W	X	Y	Z
Ciphertext	V	W	X	Y	Z	A	B	C	D	E	F	G	H	I	J	K	L	M	N	O	P	Q	R	S	T	U

Table 2

Using this encoding cipher, the plaintext

IF I HAVE SEEN FARTHER THAN OTHER MEN,
IT IS BECAUSE I HAVE STOOD ON THE SHOULDERS OF GIANTS.

would be transmitted as the following ciphertext. 25

DA D CVQZ NZZI AVMOCZM OCVI JOCZM HZI,
DO DN WZXVPNZ D CVQZ NOJJY JI OCZ NCJPGYZMN JA BDVION.

[Warning Do not spend time in this examination checking the accuracy of this or any other ciphertext.]

30

To disguise the lengths of words, it is common for ciphertext to be transmitted in blocks of fixed length, with punctuation removed. For example, the ciphertext above could be transmitted as follows.

DADCV QZNZZ IAVMO CZMOC VIJOC ZMHZI DODNW ZXVPN
ZDCVQ ZNOJJ YJIOC ZNCJP GYZMN JABDV ION

35

Notice that the decoding cipher is a shift of the alphabet in the same direction by 5 places. This is shown in Table 3.

Ciphertext	A	B	C	D	E	F	G	H	I	J	K	L	M	N	O	P	Q	R	S	T	U	V	W	X	Y	Z
Plaintext	F	G	H	I	J	K	L	M	N	O	P	Q	R	S	T	U	V	W	X	Y	Z	A	B	C	D	E

Table 3

Clearly such a cipher system is not at all secure as there are only 25 shifts of the alphabet which an interceptor would have to try to be certain of extracting the message.

Substitution cipher

40

If the sender and receiver agree in advance on a letter substitution, then a more secure cipher system can be used. Table 4 shows an example of a more secure encoding cipher.

Plaintext	A	B	C	D	E	F	G	H	I	J	K	L	M	N	O	P	Q	R	S	T	U	V	W	X	Y	Z
Ciphertext	Q	R	F	O	H	Z	K	B	D	M	T	V	A	S	I	W	E	Y	L	N	G	X	P	C	J	U

Table 4

It is unlikely that the sender or receiver would be able to remember the 26 letter substitutions and so it would be necessary to keep a written copy of the cipher. However, by writing it down there is a risk of it being discovered by an interceptor.

45

An alternative is simply to use a phrase, with repeated letters removed, to form the first few letters of the cipher. The letters not appearing in the phrase are then used in alphabetical order.

For example, removing repeated letters from the phrase

GOD WROTE THE UNIVERSE IN THE LANGUAGE OF MATHEMATICS

leaves

GODWRTEHUNIVSLAFMC

50

and this gives the ciphertext of the first 18 letters of the alphabet. The corresponding encoding cipher is given in Table 5.

Plaintext	A	B	C	D	E	F	G	H	I	J	K	L	M	N	O	P	Q	R	S	T	U	V	W	X	Y	Z
Ciphertext	G	O	D	W	R	T	E	H	U	N	I	V	S	L	A	F	M	C	B	J	K	P	Q	X	Y	Z

Table 5

If a ciphertext message based on a cipher of this type is intercepted, and the interceptor has reason to believe that letter substitution has been used, then the number of possible arrangements of the alphabet that could have been used is

55

$$26! = 403\,291\,461\,126\,605\,635\,584\,000\,000.$$

If the interceptor had the computing power to check 1 000 000 arrangements per second, whilst also checking the resulting messages to see if any were meaningful, then it would still take longer than the age of the universe to check all possibilities.

60

However, the interceptor might still have a chance of extracting the message. If the original message was in English and it was sufficiently long (about 200 letters is usually enough), then there are several techniques the interceptor might use.

- If the sender had simply encoded the words and left the gaps between the words, then it would not be difficult to discover the encoded forms of the letters A and I. This is one reason why it is normal for coded messages to be transmitted in fixed-length blocks.
- By far the most common three-letter word in English text is 'the' and the frequent appearance of a three-letter string in the ciphertext would probably give the encoded forms of T, H and E.
- In English, the letter Q is always followed by the letter U. If, in the ciphertext, one letter is always followed by the same other letter, this might give the interceptor the encoded forms of Q and U. This is one extreme example of a relationship between letters but other relationships also exist.
- Fig. 6 shows the percentage frequencies of the 26 letters in a large sample of English text from a wide variety of sources. In a sufficiently long passage of ciphertext, it would be sensible to look at those letters occurring most frequently and investigate if they could represent E, T and A. Once these letters are decoded, knowledge of the English language would quickly reveal many complete words.

65

70

75

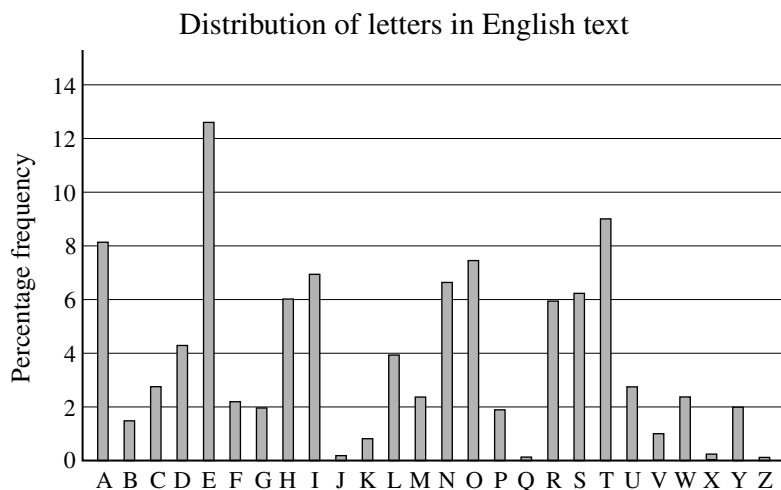

Fig. 6

Vigenère Cipher

In the ciphers mentioned above, a letter in ciphertext will always represent the same letter in the plaintext message. This is not the case with a Vigenère cipher. This cipher is illustrated using the following example.

80

First select a *keyword*. In the following example, the keyword is **ODE**. Rotations of the 26 letters of the alphabet are then written under the alphabet, starting with each of the letters in the keyword, as shown in Table 7.

Plaintext	A	B	C	D	E	F	G	H	I	J	K	L	M	N	O	P	Q	R	S	T	U	V	W	X	Y	Z
O	O	P	Q	R	S	T	U	V	W	X	Y	Z	A	B	C	D	E	F	G	H	I	J	K	L	M	N
D	D	E	F	G	H	I	J	K	L	M	N	O	P	Q	R	S	T	U	V	W	X	Y	Z	A	B	C
E	E	F	G	H	I	J	K	L	M	N	O	P	Q	R	S	T	U	V	W	X	Y	Z	A	B	C	D

Table 7

To encode a message, each of these rows is used in turn. For example, to encode the word NEWTON you would encode

- the first N using row **O**,
- the E using row **D**,
- the W using row **E**,
- the T using row **O**, and so on.

85

90

Therefore the word NEWTON would be transmitted in ciphertext as *BHAHRR*. You will notice that the two Ns in NEWTON appear as different letters in the ciphertext and the *Hs* and *Rs* in the ciphertext do not correspond to repeated letters in the plaintext.

This cipher is more secure than the others described so far but, for a sufficiently long passage of ciphertext, it is still vulnerable to frequency analysis, especially if the keyword is short. For example, consider the following ciphertext (in which the keyword used is not **ODE**).

95

<i>NUMFU</i>	<i>GPXGN</i>	<i>BBWVI</i>	<i>GMCIM</i>	<i>NRZGM</i>	<i>YQDYG</i>	<i>PXJNQ</i>	<i>GNRZL</i>	
<i>IEBAY</i>	<i>CWXNF</i>	<i>UNMGJ</i>	<i>XVRIN</i>	<i>NVNNF</i>	<i>GPXCQ</i>	<i>MTMYQ</i>	<i>DYGPX</i>	
<i>WBTHO</i>	<i>EAHLG</i>	<i>PXQBZ</i>	<i>WMZCL</i>	<i>NSQMN</i>	<i>BOXNU</i>	<i>MKCAI</i>	<i>AUEUH</i>	
<i>HVWNM</i>	<i>JIRVR</i>	<i>INNLO</i>	<i>LNUMY</i>	<i>CEAMN</i>	<i>RAMNU</i>	<i>MKYVA</i>	<i>GICMK</i>	100
<i>GNVXH</i>	<i>GXEUP</i>	<i>MBHGP</i>	<i>XQBZE</i>	<i>XSWKO</i>	<i>TTRGN</i>	<i>BAYZI</i>	<i>MCPA</i>	

The string ***GPXQBZ*** appears twice, one a shift of 84 places from the other. It is reasonable to assume that in both cases the same six-letter string in the plaintext has been encoded. If this is indeed the case then the length of the keyword must be a factor of 84. There are also two occurrences of the string ***NUMK***, one a shift of 40 places from the other. Taken together, these two shifts suggest that the keyword has length 2 or 4.

105

Assume that the keyword is of length 4, since a keyword of length 2 would form a less secure cipher than one of length 4.

To carry out a frequency analysis, the ciphertext is split into four strings, S_1 , S_2 , S_3 and S_4 , each made up of every fourth letter of the original ciphertext.

110

S_1 : *NUGWMNMYJNINMNVNFCMYWOLQMNNNCUHMVNNCNNYIGHUHQXOGYC*
 S_2 : *UGNVCRYGNRECFGRVGYGBEGBZSBUAJEVJRLUERUVCNGPGBSTNZP*
 S_3 : *MPBIIIZQPQZBWUJINPMQPTAPZCQOMIUWIIQMAAMAMVXMPZWTBIA*
 S_4 : *FXBGMGDXGLAXNXNNXTDXHHXWLMXKAHNRNL YMMKGKXEBXEKRAM*

These text strings may be analysed using the information in Fig. 6. (The analysis may not always be successful with strings as short as these.)

115

Notice the following two characteristics of the distribution shown in Fig. 6.

- The three highest frequencies correspond to E, T and A.
- After the peak at T there is a run of six letters with low frequencies; this is the longest such run.

120

Compare this distribution with the distribution of letters in the first text string, S_1 , shown in Fig. 8 below.

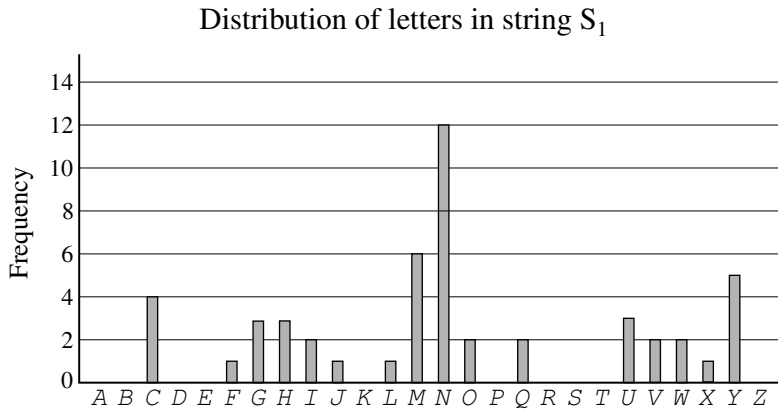

Fig. 8

There are two reasons to suspect that the letter N in string S_1 is the encoded form of the letter T .

- N in Fig. 8 is followed by a run of six letters with low frequency.
- The corresponding encoded forms of A and E would be U and Y respectively; both of these occur quite frequently.

125

These two reasons suggest that it is worth looking more closely at this particular shift.

Starting the distribution at U , as shown in Fig. 9, allows a direct comparison to be made with the distribution in Fig. 6.

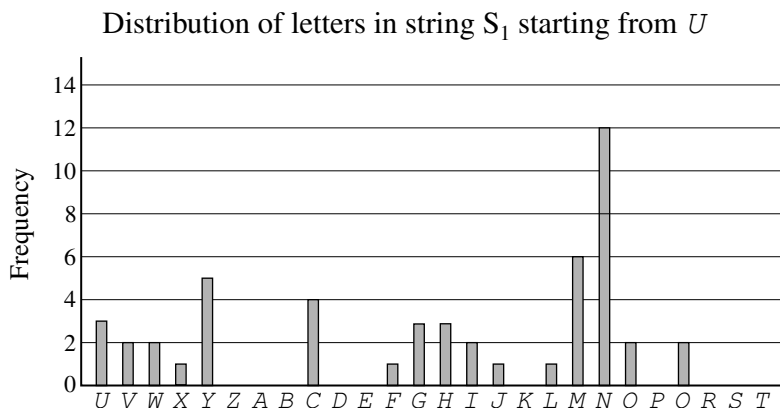

Fig. 9

The string is made up of only 50 letters so a very close match with Fig. 6 is not to be expected. However the distributions are sufficiently similar to accept this shift for now and investigate the other three strings; it is only after all four strings have been decoded that we can determine if the shifts are correct.

130

The frequency distributions corresponding to the strings S_2 , S_3 and S_4 are shown in Figs. 10, 11 and 12 respectively.

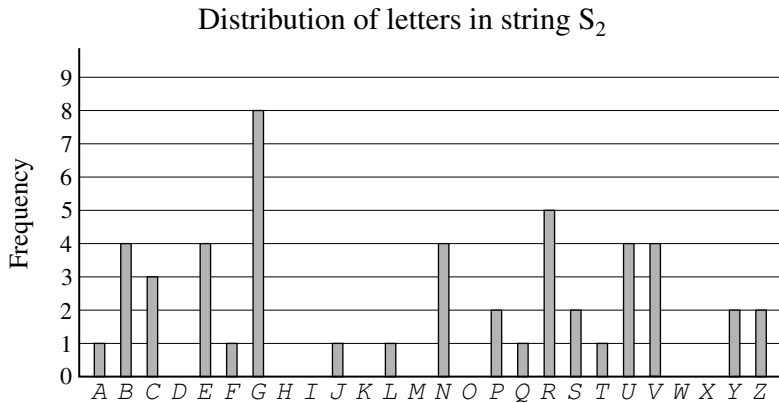

Fig. 10

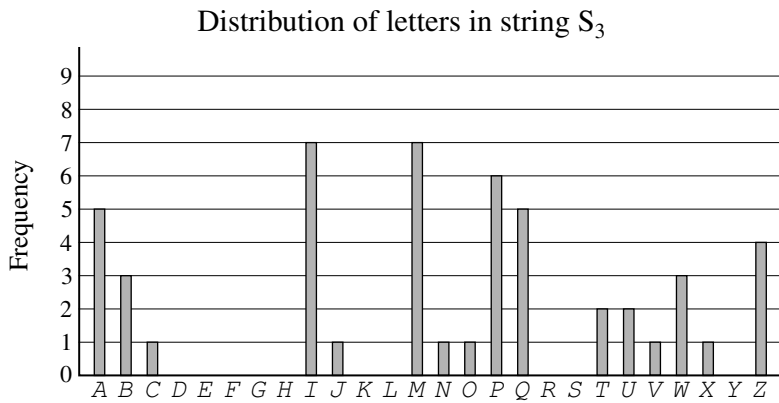

Fig. 11

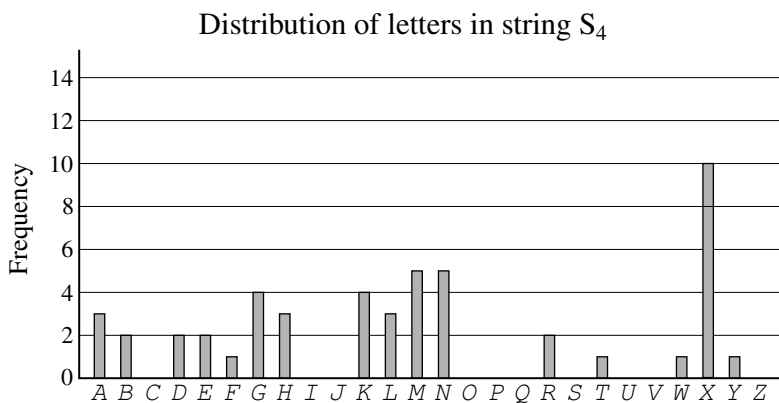

Fig. 12

By employing reasoning similar to that used in the analysis of string S_1 , it is likely that

- in string S_2 , the encoded form of the letter A is N ,
- in string S_3 , the encoded form of the letter A is I .

For string S_4 it is not quite so clear. However, it may be the case that the keyword used is a word in the English language. So it is sensible to check, in string S_4 , if the encoded form of the letter A is T since this would make the four-letter keyword **UNIT**. With this keyword, the strings S_1 , S_2 , S_3 and S_4 are decoded to give the following strings. 140

T_1 : TAMCSTSEPTOETSBLISECURWSTTTIANSBTTITTEOMNANWDUMEI
 T_2 : HTAIPELTAERPSTEITDLTORTOMFOHNRIWEYHREHIPATCTOFGAMC
 T_3 : EHTAARIHIRTOMBFAFHEIHLSHRUIGEAMOAAIESSESENPEHROLTAS 145
 T_4 : MEINTNKENSHEUEUEAKEOOEDSTERHOUYUSFTTRNRELIELRYHT

This does indeed result in a meaningful plaintext message.

In conclusion

The methods considered have all involved substituting each letter with another letter. Variations on these are possible, such as having an encoded form of each of the 676 two-letter pairs (such as AA, AB, AC, ...) or encoding a message using one cipher and then encoding the resulting ciphertext using another cipher. 150

The science of cryptography affects all our lives. Every time you send an email, use a cashpoint machine or make purchases on the internet, the information you transmit is encoded so that only your intended recipient can read it. 155

Government intelligence is heavily dependent upon the ability to transmit information securely whilst also trying to break the ciphers used by others. Indeed, it is estimated that the Second World War was shortened by two years, thereby saving many lives, thanks to the intelligence gained by the mathematicians working in cryptography at Bletchley Park.

As computing power becomes more sophisticated, more secure codes are continually being sought. The most secure codes in use today rely heavily on techniques from pure mathematics. 160



Copyright Information

OCR is committed to seeking permission to reproduce all third-party content that it uses in its assessment materials. OCR has attempted to identify and contact all copyright holders whose work is used in this paper. To avoid the issue of disclosure of answer-related information to candidates, all copyright acknowledgements are reproduced in the OCR Copyright Acknowledgements Booklet. This is produced for each series of examinations, is given to all schools that receive assessment material and is freely available to download from our public website (www.ocr.org.uk) after the live examination series.

If OCR has unwittingly failed to correctly acknowledge or clear any third-party content in this assessment material, OCR will be happy to correct its mistake at the earliest possible opportunity.

For queries or further information please contact the Copyright Team, First Floor, 9 Hills Road, Cambridge CB2 1GE.

OCR is part of the Cambridge Assessment Group; Cambridge Assessment is the brand name of University of Cambridge Local Examinations Syndicate (UCLES), which is itself a department of the University of Cambridge.

ADVANCED GCE

MATHEMATICS (MEI)

Applications of Advanced Mathematics (C4) Paper B: Comprehension

4754B

Candidates answer on the Question Paper

OCR Supplied Materials:

- Insert (inserted)
- MEI Examination Formulae and Tables (MF2)

Other Materials Required:

- Rough paper
- Scientific or graphical calculator

Wednesday 9 June 2010
Afternoon

Duration: Up to 1 hour



Candidate Forename		Candidate Surname	
--------------------	--	-------------------	--

Centre Number						Candidate Number				
---------------	--	--	--	--	--	------------------	--	--	--	--

INSTRUCTIONS TO CANDIDATES

- Write your name clearly in capital letters, your Centre Number and Candidate Number in the boxes above.
- Use black ink. Pencil may be used for graphs and diagrams only.
- Read each question carefully and make sure that you know what you have to do before starting your answer.
- Answer **all** the questions.
- Do **not** write in the bar codes.
- Write your answer to each question in the space provided. Additional paper may be used if necessary but you must clearly show your Candidate Number, Centre Number and question number(s).
- You are permitted to use a graphical calculator in this paper.
- Final answers should be given to a degree of accuracy appropriate to the context.

INFORMATION FOR CANDIDATES

- The number of marks is given in brackets [] at the end of each question or part question.
- The insert contains the text for use with the questions.
- You may find it helpful to make notes and do some calculations as you read the passage.
- You are **not** required to hand in these notes with your question paper.
- You are advised that an answer may receive **no marks** unless you show sufficient detail of the working to indicate that a correct method is being used.
- The total number of marks for this paper is **18**.
- This document consists of **4** pages. Any blank pages are indicated.

INSTRUCTION TO EXAMS OFFICER / INVIGILATOR

- This paper should be attached to the candidate's paper A script before sending to the examiner.

Examiner's Use Only:	
1	
2	
3	
4	
5	
Total	

- 1 The train journey from Swansea to London is 307 km and that by road is 300 km. Carry out the calculations performed on the First Great Western website to estimate how much lower the carbon dioxide emissions are when travelling by rail rather than road. [2]

.....

.....

.....

.....

- 2 The equation of the curve in Fig. 3 is

$$y = \frac{1}{10^4}(x^3 - 100x^2 - 10\,000x + 2\,100\,100).$$

Calculate the speed at which the car has its lowest carbon dioxide emissions and the value of its emissions at that speed. [6]

[An answer obtained from the graph will be given no marks.]

.....

.....

.....

.....

.....

.....

.....

- 3 (i) In line 109 the carbon dioxide emissions for a particular train journey from Exeter to London are estimated to be 3.7 tonnes. Obtain this figure. [2]
- (ii) The text then goes on to state that the emissions per extra passenger on this journey are less than $\frac{1}{2}$ kg. Justify this figure. [1]

(i)

.....

(ii)

.....

4 The daily number of trains, n , on a line in another country may be modelled by the function defined below, where P is the annual number of passengers.

- $n = 10$ for $0 \leq P < 10^6$
- $n = 11$ for $10^6 \leq P < 1.5 \times 10^6$
- $n = 12$ for $1.5 \times 10^6 \leq P < 2 \times 10^6$
- $n = 13$ for $2 \times 10^6 \leq P < 2.5 \times 10^6$
- $n = 14$ for $2.5 \times 10^6 \leq P < 3 \times 10^6$
- ... and so on ...

(i) Sketch the graph of n against P . [2]

(ii) Describe, in words, the relationship between the daily number of trains and the annual number of passengers. [2]

(i)



(ii)

.....

.....

[Question 5 is printed overleaf.]

5 The FGW website gives the conversion factor for miles to kilometres to 7 significant figures.

“We got the distance between the two stations by road from theaa.com. We then converted this distance to kilometres by multiplying it by 1.609344.”

Suppose this conversion factor is applied to a distance of exactly 100 miles.

State which one of the following best expresses the level of accuracy for the distance in metric units, justifying your answer.

- A : to the nearest millimetre
- B : to the nearest 10 centimetres
- C : to the nearest metre

[3]

.....

.....

.....

.....



Copyright Information

OCR is committed to seeking permission to reproduce all third-party content that it uses in its assessment materials. OCR has attempted to identify and contact all copyright holders whose work is used in this paper. To avoid the issue of disclosure of answer-related information to candidates, all copyright acknowledgements are reproduced in the OCR Copyright Acknowledgements Booklet. This is produced for each series of examinations, is given to all schools that receive assessment material and is freely available to download from our public website (www.ocr.org.uk) after the live examination series.

If OCR has unwittingly failed to correctly acknowledge or clear any third-party content in this assessment material, OCR will be happy to correct its mistake at the earliest possible opportunity.

For queries or further information please contact the Copyright Team, First Floor, 9 Hills Road, Cambridge CB2 1GE.

OCR is part of the Cambridge Assessment Group; Cambridge Assessment is the brand name of University of Cambridge Local Examinations Syndicate (UCLES), which is itself a department of the University of Cambridge.

ADVANCED GCE

MATHEMATICS (MEI)

Applications of Advanced Mathematics (C4) Paper B: Comprehension

INSERT

4754B

Wednesday 9 June 2010
Afternoon

Duration: Up to 1 hour



INFORMATION FOR CANDIDATES

- This insert contains the text for use with the questions.
- This document consists of **8** pages. Any blank pages are indicated.

INSTRUCTION TO EXAMS OFFICER / INVIGILATOR

- Do not send this insert for marking; it should be retained in the centre or destroyed.

Greener travel

Introduction

As the evidence for global warming becomes more compelling, many people are looking at the opportunities in their daily lives to reduce the impact they are having on the environment. One common choice is whether to travel by train or to drive. This article compares the carbon dioxide (CO₂) emissions from these two forms of transport. 5

A simple model

Several railway companies' websites include estimates of the reduction in carbon dioxide emissions per passenger for those who travel by train. For example, on the First Great Western website, you can enter the journey, say Exeter to London, and be told "Train 16.83 kg, Car 41.7 kg". The implication is that by choosing to travel this route by train rather than by car you prevent 24.87 kg of carbon dioxide entering the atmosphere. 10

First Great Western (FGW) also tell you how the calculations are carried out.

We calculated the CO₂ emissions per passenger for trains as follows:

We got the distance between the two stations from the National Rail Timetable. We then converted this distance to kilometres by multiplying it by 1.609344. 15

We calculated the carbon emissions by multiplying the distance in kilometres by 0.0602, the conversion factor for rail (Defra3).

We calculated the CO₂ emissions per passenger for cars as follows:

We got the distance between the two stations by road from theaa.com. 20

We then converted this distance to kilometres by multiplying it by 1.609344.

We calculated the carbon emissions for the journey by multiplying the distance in kilometres by 0.2095, the conversion factor for an average petrol car (Defra3).

We then divided this figure by 1.58, the average loading for a car (DfT4), to find the carbon emissions for this journey per passenger. 25

We calculated the carbon saving of taking the train instead of the car by simply subtracting the rail carbon emissions from the car carbon emissions.

Note	Defra3 is a document published by the Department for Food and Rural Affairs. DfT4 is a document published by the Department for Transport.
------	---

The fact that FGW have explained how the calculations are carried out is good practice. It allows people to look carefully at them, as is being done in this article, and to make their own judgements. 30

Outcomes from the website

The outcomes reported on the website raise questions.

Accuracy

The carbon dioxide emissions are given to 3 significant figures in one case and 4 in the other. This suggests that the figures on which they are based are all very accurate. Is this level of accuracy 35

justified? The discussion in the rest of this article suggests that the answer is “No”. The level of variability is such that it would be hard to justify even 2 significant figures.

The target audience

The website appears to be answering an individual traveller who asks the following question. 40

How much less carbon dioxide will enter the atmosphere if I decide to travel by train rather than by car?

However, the calculations answer a different question.

How much less carbon dioxide on average will enter the atmosphere for a train traveller compared to a car traveller for the journey in question? 45

The answers will usually be very different.

Carbon dioxide emissions

This article compares the carbon dioxide emissions that result from travelling by car (using petrol or diesel fuel) and by train (using diesel fuel). When people talk about ‘carbon emissions’ they are talking about carbon dioxide (together with any carbon monoxide that is also produced). 50

The main elements in diesel are carbon and hydrogen; the numbers of atoms are in the ratio of about 12 : 23. When diesel is burnt, the main products are water and carbon dioxide. One litre of diesel has mass 0.85 kg; when it is burnt it results in about 2.7 kg of carbon dioxide entering the atmosphere. (There are also small quantities of other elements which can have damaging effects on the environment.) 55

Petrol is lighter; one litre has mass 0.72 kg and produces 2.3 kg of carbon dioxide. A litre of petrol produces less carbon dioxide than a litre of diesel. However, because diesel engines are more efficient, they use less fuel and so create less carbon dioxide, typically by 10% to 20%.

The carbon dioxide emissions for a car

Particular cars 60

The calculation for the carbon dioxide emissions from a car is based on the Defra figure that an ‘average car’ emits 0.2095 kg of carbon dioxide per kilometre. This raises the question of what is an ‘average car’ in terms of emissions.

At the time of writing, the least polluting cars are rated at 99 grams per kilometre, the most polluting at 495. The results of a recent survey of the emissions of different models of new cars are given in Table 1. 65

Emission rating (g km⁻¹)	% of models
0 – 100	0.1
101 – 120	4.5
121 – 150	18.6
151 – 165	17.1
166 – 185	18.8
186 – 225	24.7
> 225	16.1

Table 1 (Source: www.carpages.co.uk)

The First Great Western website appears to tell car travellers the levels of carbon dioxide emissions for which they would be responsible. However, it does not ask them what type of car they would be driving. Table 2 gives the distributions of the carbon dioxide emissions for hatchbacks and SUVs (Sport Utility Vehicles).

70

Emission rating (g km^{-1})	% of hatchback models	% of SUV models
0 – 100	0.4	0
101 – 120	12.0	0
121 – 150	37.7	0
151 – 165	23.1	0
166 – 185	15.3	6.8
186 – 225	10.6	42.1
> 225	0.8	51.1

Table 2 (Source: www.carpages.co.uk)

The contrast is striking. It is clear that the carbon dioxide emissions from a car are highly dependent on its type.

Average emissions

The calculation on the FGW website is based on an ‘average’ emission of 0.2095 kilograms of carbon dioxide per kilometre, the figure provided by Defra.

75

The median of the distribution in Table 1 is in the class labelled $166 - 185 \text{ g km}^{-1}$, and so is less than the Defra figure. The data, as presented in the table, do not allow a mean value to be calculated, but those who carried out the survey say that it is 186 g km^{-1} ; this again is less than the Defra figure.

There are a number of possible reasons for this difference and it may well be that the rather higher Defra figure is actually more realistic.

80

- The data in Table 1 are for new cars, many of which have lower carbon dioxide emissions than older cars that are still on the road.
- Table 1 gives the distribution of models of cars, rather than that of actual cars on the road.
- The emissions figures in the table would have been obtained when the cars were being driven in test conditions. The emissions depend on the speed at which a car is being driven. Fig. 3 shows a typical graph of the carbon dioxide emissions of a car plotted against its speed.

85

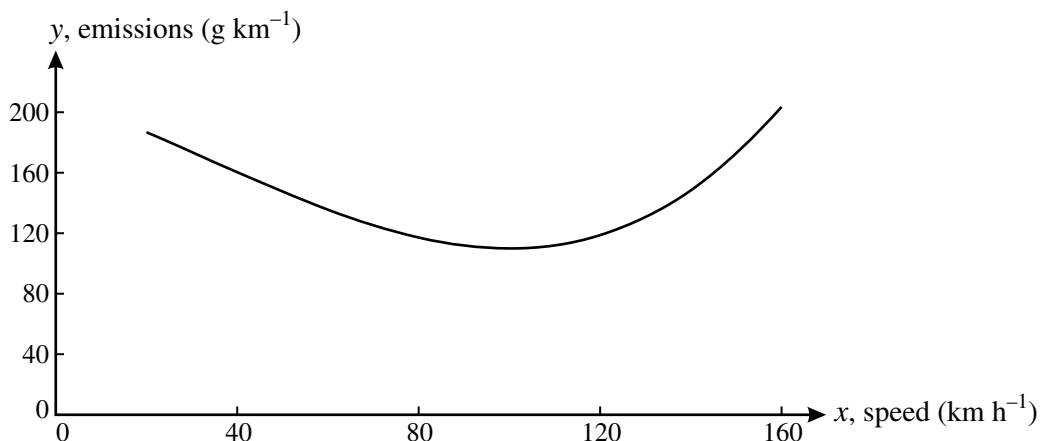

Fig. 3

The carbon dioxide emissions for a train

The figures for train travel also present problems.

Passenger trains vary from single coach vehicles to those with eight or more coaches. Some are powered by diesel, others by electricity. Electricity may be generated by coal-fired power stations with high carbon dioxide emissions; by contrast generation from nuclear, hydro-electric or wind power produces no emissions at all. However, in general electric trains are responsible for much lower emissions. 90

The FGW website calculation uses the Defra figure of 0.0602 kilograms of carbon dioxide per passenger per kilometre. This too is an average figure, and so one that does not correspond to any particular train journey. 95

It is, however, possible to be reasonably precise about a particular journey. The example at the start of this article was the journey from Exeter to London with FGW. This defines the type of train being used, in this case an HST (High Speed Train), and, subject to the number of stops it makes on the way, its speed at each part of the journey. The HST uses diesel fuel and so its carbon dioxide emissions may be compared with those from a car. 100

Three things need to be considered when estimating the carbon dioxide emissions: the distance travelled, the number of passengers (and so their weight) and the number of stops.

All the HSTs run by FGW have recently been fitted with new motors. Reasonable estimates of emissions are shown in Table 4. 105

Cause	Emission rate
Distance travelled, d km	10 kg per kilometre
Number of passengers, p	1.5 grams per passenger per kilometre
Number of stops, s	200 kg per stop

Table 4

(A lot of energy is required to get a train up to speed after a stop.)

So the total emissions, E kg, are given by the formula: $E = (10 + 0.0015p)d + 200s$.

The distance, by rail, from Exeter to London is 279 km, so the emissions for a journey with 4 stops and 250 passengers (a half full train) are about 3.7 tonnes.

Note that the emissions per extra passenger on the Exeter to London journey are less than $\frac{1}{2}$ kg. 110

There are two ways of looking at this journey.

- An individual view. Someone considering how to travel can argue

Since the train is running anyway, I will have almost no effect on its carbon dioxide emissions. By contrast, if I travel by my car, with carbon dioxide emissions of about 140 grams per kilometre, I will be responsible for putting about 44 kg of carbon dioxide into the atmosphere. 115

(The journey by road is about 314 km according to theaa.com.)

- An average view. Someone looking at the overall impact of this train on the environment might say

The total emissions of 3.7 tonnes need to be averaged out over the 250 passengers, giving a figure of 14.8 kg per passenger. 120

So the outcomes of the calculations can be interpreted in two ways. If you take the individual view, FGW are greatly understating the value to the environment of people travelling by train. On the

other hand, if you take the average view, their figure of 16.83 kg of carbon dioxide is similar to the 14.8 kg for the particular journey in the example and so is realistic.

125

Which of the two is the better interpretation?

To answer that question you need to look at the relationship between overcrowding and the number of trains being run. This is a complex issue; the following section explores only part of it and considers a simple initial model.

Crowded trains

130

It can be argued that if many more people decided to travel by train, the trains would become overcrowded and eventually this would result in more trains running. At the time of writing, 17 High Speed Trains run every weekday from Exeter to London. An increase in passenger numbers might cause this to be increased to 18 and a further increase to 19 and so on.

Thus, although an individual decision to travel by train results in very little extra carbon dioxide entering the atmosphere, when sufficient people regularly make the same decision and so cause an extra train to run, then their combined decisions have resulted in the extra emissions from the new train.

135

The daily number of trains might thus be modelled as a step function of the daily number of passengers. Such a step function is illustrated in the graph in Fig. 5. (There is no simple algebraic formula for such a step function.)

140

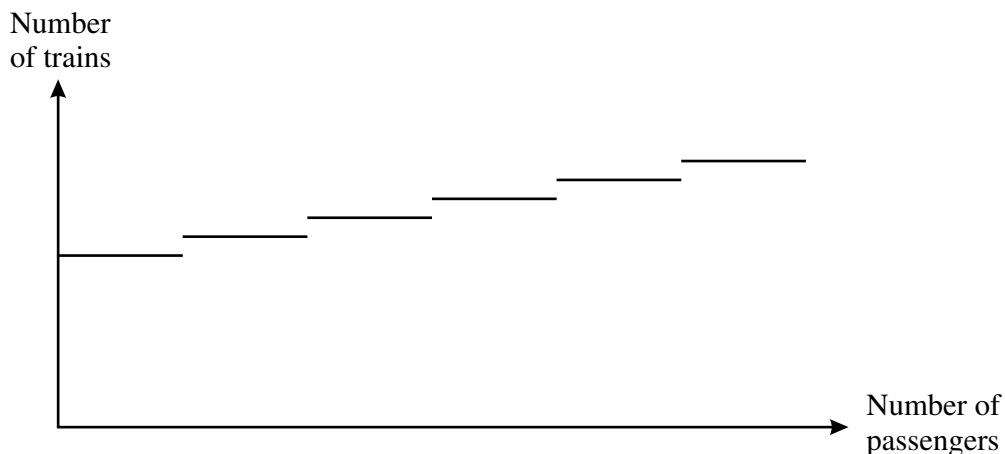

Fig. 5

If this model were realistic, then the average view would probably be preferable. However, this is not the case.

In recent years the number of people travelling by train has increased substantially and is continuing to do so, but this has not resulted in a corresponding increase in the number of trains running; rather they have become more and more crowded. There are two main reasons for this.

145

- There are not enough suitable trains. Virtually all the available trains in the country are now being fully used.
- In many places the railway lines are used to capacity. To run more trains would require major investment in improved signalling, or even additional railway lines.

150

In the short term it is likely that the response to overcrowding will often be to run longer trains. Adding an extra coach to a train will certainly increase its carbon dioxide emissions, but to nothing

like the extent that would result from running an extra train. So the individual view is probably closer to reality than the average view.

It is also possible that, faced with the necessity of substantial long-term investment to deal with overcrowding, a decision will be made to electrify significant sections of the railway, and this would reduce carbon dioxide emissions.

155

OCR would like to thank First Great Western for their help in preparing this article.

**ADVANCED GCE
MATHEMATICS (MEI)**

4754B

Applications of Advanced Mathematics (C4) Paper B: Comprehension

Candidates answer on the question paper.

OCR supplied materials:

- Insert (inserted)
- MEI Examination Formulae and Tables (MF2)

Other materials required:

- Scientific or graphical calculator
- Rough paper

**Friday 14 January 2011
Afternoon**

Duration: Up to 1 hour



Candidate forename		Candidate surname	
--------------------	--	-------------------	--

Centre number						Candidate number				
---------------	--	--	--	--	--	------------------	--	--	--	--

INSTRUCTIONS TO CANDIDATES

- The insert will be found in the centre of this document.
- Write your name, centre number and candidate number in the boxes above. Please write clearly and in capital letters.
- Write your answer to each question in the space provided. Additional paper may be used if necessary but you must clearly show your candidate number, centre number and question number(s).
- Use black ink. Pencil may be used for graphs and diagrams only.
- Read each question carefully. Make sure you know what you have to do before starting your answer.
- Answer **all** the questions.
- Do **not** write in the bar codes.
- The insert contains the text for use with the questions.
- You are permitted to use a scientific or graphical calculator in this paper.
- Final answers should be given to a degree of accuracy appropriate to the context.

INFORMATION FOR CANDIDATES

- The number of marks is given in brackets [] at the end of each question or part question.
- You may find it helpful to make notes and do some calculations as you read the passage.
- You are **not** required to hand in these notes with your question paper.
- You are advised that an answer may receive **no marks** unless you show sufficient detail of the working to indicate that a correct method is being used.
- The total number of marks for this paper is **18**.
- This document consists of **8** pages. Any blank pages are indicated.

INSTRUCTION TO EXAMS OFFICER / INVIGILATOR

- This paper should be attached to the candidate's paper A script before sending to the examiner.

Examiner's Use Only:	
1	
2	
3	
4	
5	
6	
Total	

- 1 The gallery shown below is a 3 by 4 grid of rectangular rooms.

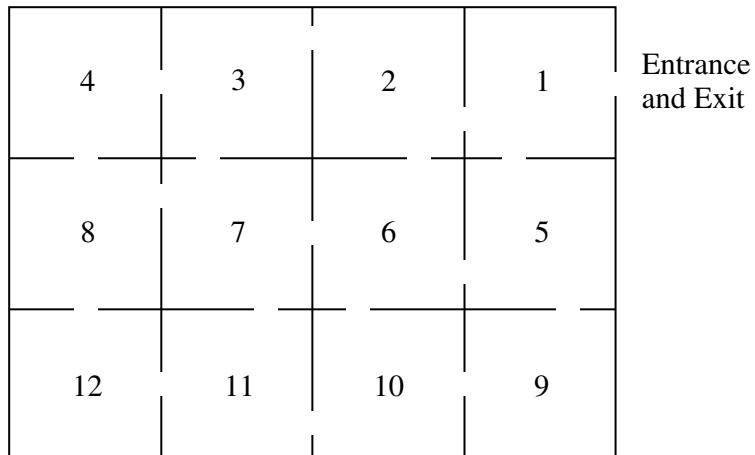

- (i) Mark on the diagram the positions of six guards so that the whole gallery can be observed. [1]

- (ii) Give a counterexample to disprove the following proposition:

For an m by n grid of rectangular rooms, $\left\lfloor \frac{mn}{2} \right\rfloor$ guards are required. [2]

- 2 (i) Show that $\frac{(2r+1) - (-1)^r}{4} = \left\lfloor \frac{r+1}{2} \right\rfloor$ in the case where $r = 4$. [2]

.....

.....

.....

- (ii) The ceiling function, $\lceil x \rceil$, is defined as the smallest integer greater than or equal to x .

Complete the following table. [2]

x	1	2	3	4	5
$\lceil \frac{x}{2} \rceil$					

- 3 Justify the statement in lines 79 and 80. [2]

.....

.....

.....

.....

- 4 (i) Following the procedure in Fig. 6, complete the labelling of the polygon shown below. [2]

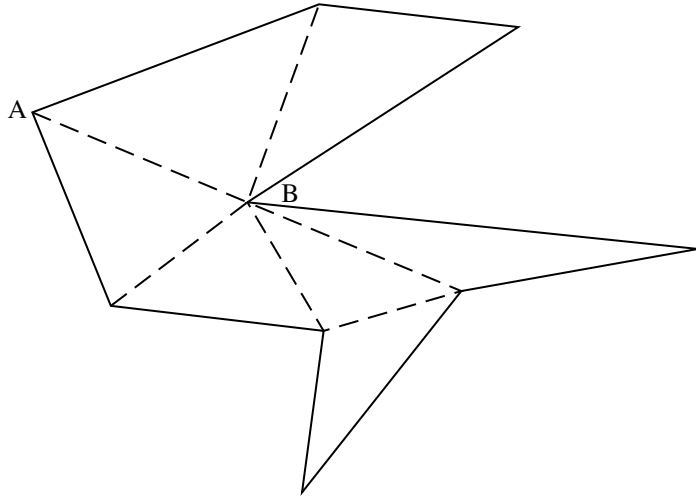

- (ii) In order to use the minimum number of cameras, show on the diagram below where your answer to part (i) indicates the cameras should be placed. [1]

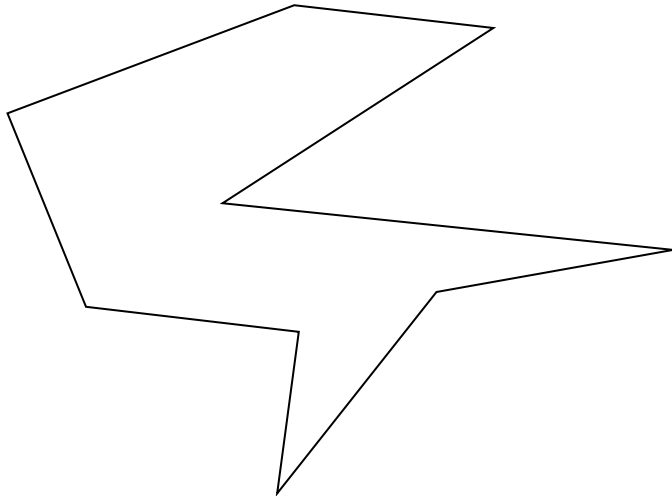

- 5 With reference to the labelled triangulation shown below, state with a reason whether each of the following statements is true or false.

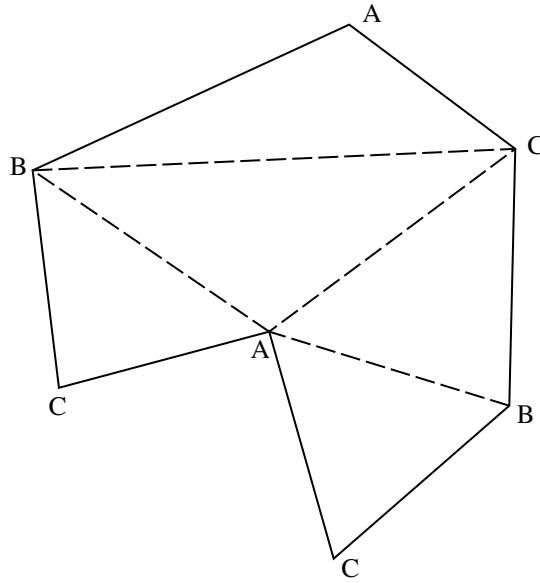

- (i) The triangulation shows that 2 cameras are sufficient. [2]

.....
Reason:
.....

- (ii) The triangulation shows that 2 cameras are necessary. [2]

.....
Reason:
.....

- 6 On lines 96 and 97 it says “If the cameras did not need to be mounted on the walls, but could be positioned further away from the building, then fewer cameras would usually suffice.”

Using the diagram below, which shows a pentagon and one external camera, C, indicate by shading the region in which a second camera must be positioned so that all the walls could be observed by the two cameras. [2]

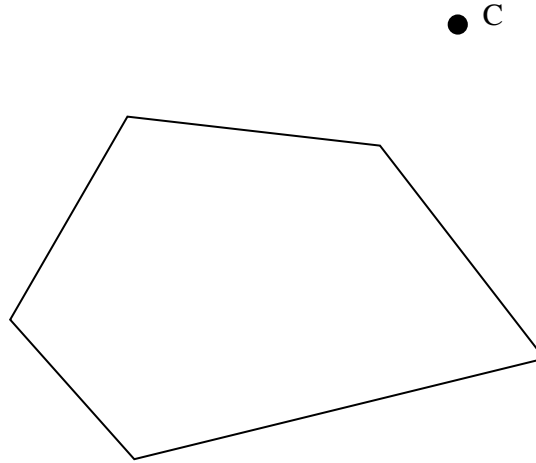

**ADVANCED GCE
MATHEMATICS (MEI)**

4754B

Applications of Advanced Mathematics (C4) Paper B: Comprehension

INSERT

**Friday 14 January 2011
Afternoon**

Duration: Up to 1 hour



INFORMATION FOR CANDIDATES

- This insert contains the text for use with the questions.
- This document consists of **12** pages. Any blank pages are indicated.

INSTRUCTION TO EXAMS OFFICER / INVIGILATOR

- Do not send this insert for marking; it should be retained in the centre or destroyed.

The Art Gallery Problem

Introduction

Closed-circuit television (CCTV) is widely used to monitor activities in public areas. Usually a CCTV camera is fixed to a wall, either on the inside or the outside of a building, in such a way that it can rotate to survey a wide region. 5

Art galleries need to take surveillance very seriously. Many galleries use a combination of guards, who can move between rooms, and fixed cameras.

This article addresses the problem of how to ensure that all points in a gallery can be observed, using the minimum number of guards or cameras. Two typical layouts will be considered: a standard layout consisting of a chain of rectangular rooms with one route through them; and a polygonal, open-plan gallery. 10

Standard layout

Fig. 1 shows the plan view of an art gallery. It contains six rectangular rooms in a chain.

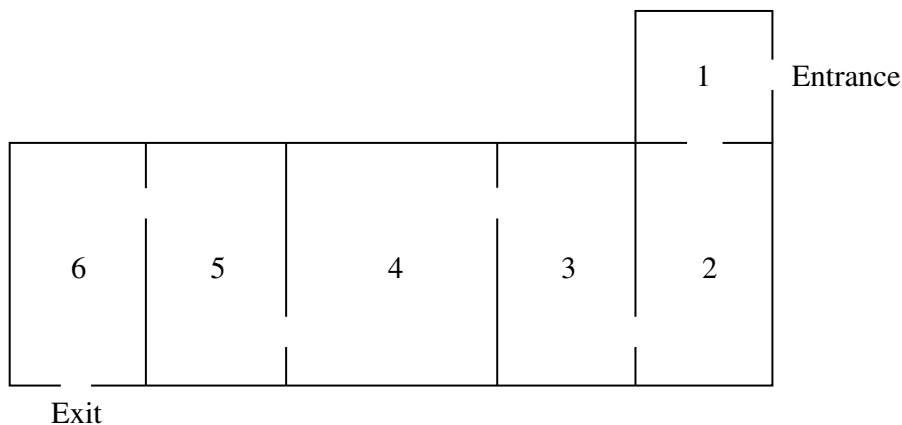

Fig. 1

Imagine you want to employ the minimum number of guards so that every point in the gallery can be observed by at least one of them. How many guards are needed and where would you position them? 15

It turns out that 3 guards are needed; they should be positioned in the doorways between rooms 1 and 2, rooms 3 and 4 and rooms 5 and 6.

Table 2 shows the number of guards, G , needed for different numbers of rectangular rooms, r , arranged in a chain. 20

Number of rooms, r	1	2	3	4	5	6	7	8	9	10
Number of guards, G	1	1	2	2	3	3	4	4	5	5

Table 2

One formula which expresses G in terms of r is

$$G = \frac{(2r + 1) - (-1)^r}{4}.$$

This can be expressed more concisely using the ‘floor function’, denoted by $\lfloor x \rfloor$. This is defined as the greatest integer less than or equal to x . For example, $\lfloor 3.9 \rfloor = 3$ and $\lfloor 5 \rfloor = 5$.

Using this notation, the formula which expresses G in terms of r is

$$G = \left\lfloor \frac{r + 1}{2} \right\rfloor.$$

It has been assumed that the thickness of the walls does not obscure the view of a guard positioned in a doorway. In reality the guard would need to take a step into a room to ensure that he or she can see into all corners. In this sense, guards have the advantage over fixed cameras as the thickness of the walls between rooms would result in the view of a camera positioned in a doorway being partially blocked.

The remainder of this article is concerned with positioning fixed cameras in galleries which are not divided into separate rooms.

Open-plan gallery

An open-plan gallery has no interior walls.

Figs 3a, 3b, 3c and 3d show the plan views of four different open-plan galleries. Each one is made up of 12 straight exterior walls with no interior walls.

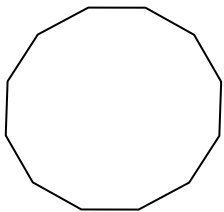

Fig. 3a

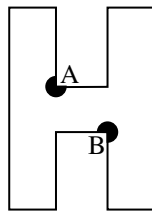

Fig. 3b

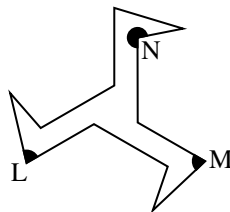

Fig. 3c

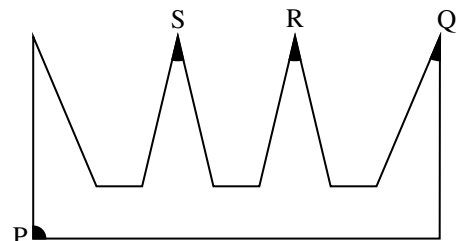

Fig. 3d

Fig. 3a is a gallery in the shape of a convex dodecagon. A single camera mounted at any point on any wall would be able to observe the entire gallery.

In order to ensure that all points can be observed, it turns out that the galleries shown in Figs 3b, 3c and 3d require 2, 3 and 4 cameras respectively. Possible positions for the cameras are shown. The cameras do not have to be positioned in corners but corners are often convenient locations for them.

An interesting question is whether there could be an open-plan gallery with 12 straight walls that requires more than 4 cameras.

A procedure called *triangulation* helps to answer this question and to determine how many cameras may be required for open-plan galleries with any number of walls. This will be illustrated for a gallery with 11 walls.

Triangulation

Fig. 4 shows a polygon with 11 edges.

50

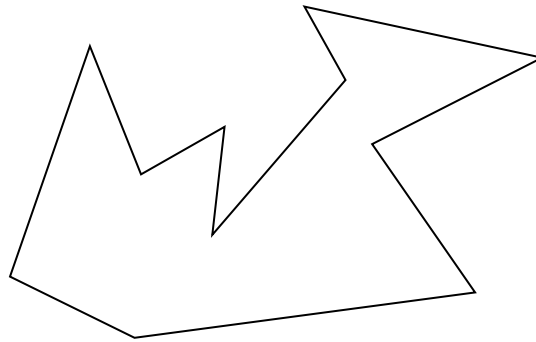

Fig. 4

It can be proved that every polygon can be split into triangles without creating any new vertices; this procedure is called triangulation. Figs 5a and 5b show two ways of triangulating the polygon shown in Fig. 4.

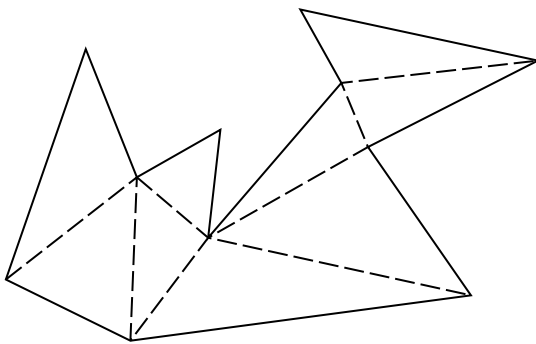

Fig. 5a

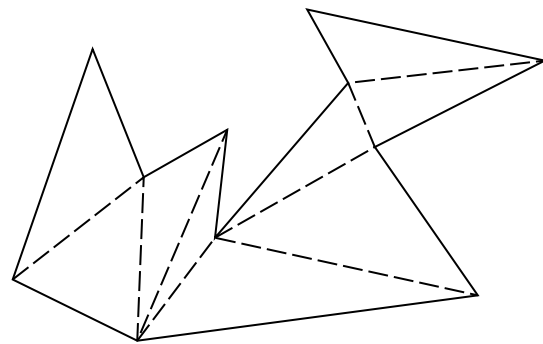

Fig. 5b

There is a two-stage process to decide on possible positions of the cameras in an open-plan gallery. The first stage is to add new internal edges to triangulate the polygon which represents the gallery. Then each vertex is labelled either A, B or C using the procedure shown in Fig. 6.

55

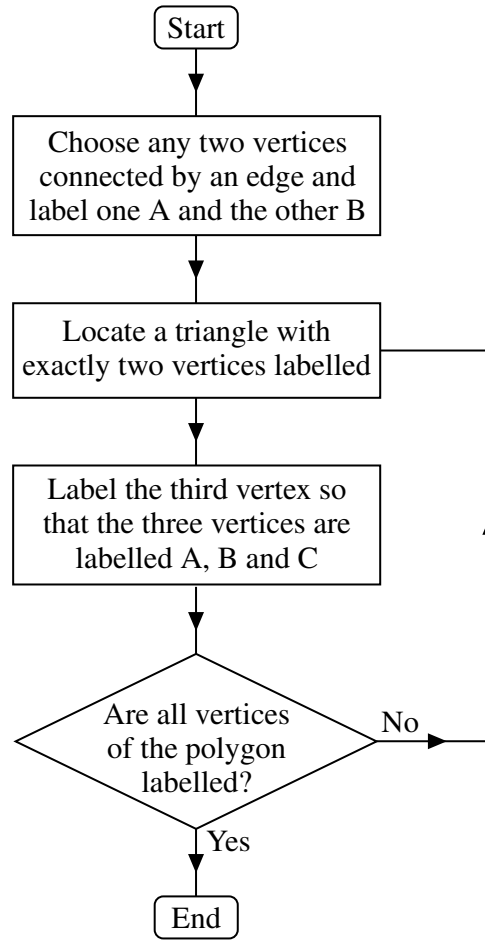

Fig. 6

This procedure is illustrated using the polygon in Fig. 4; for ease of reference the polygon has been reproduced in Fig. 7 with the vertices numbered 1 to 11.

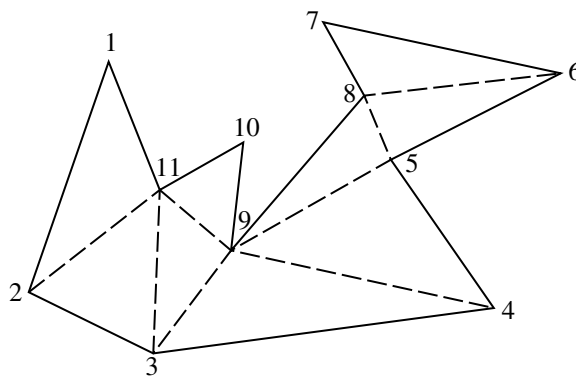

Fig. 7

Fig. 8 shows the result after choosing vertices 1 and 2 and labelling them A and B respectively.

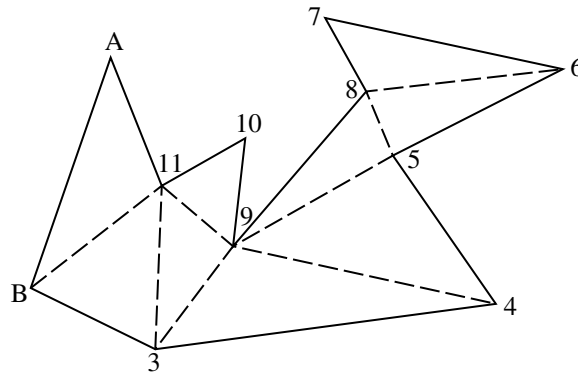

Fig. 8

Vertex 11 is now assigned the label C so that this triangle (shaded in Fig. 9) has vertices labelled A, B and C.

60

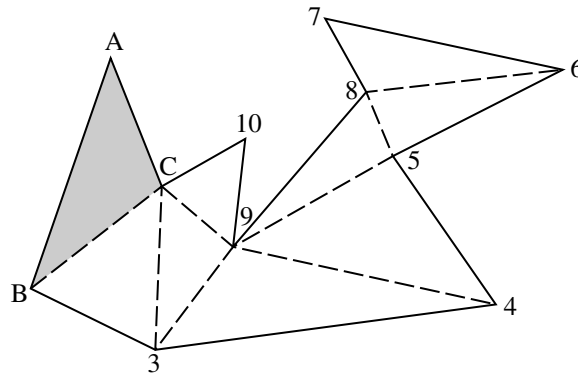

Fig. 9

The next vertex to be labelled is vertex 3; this is assigned the label A. The remaining vertices are labelled in the following order.

Vertex 9 is labelled B;

Vertex 10 is labelled A;

Vertex 4 is labelled C;

Vertex 5 is labelled A;

Vertex 8 is labelled C;

Vertex 6 is labelled B;

Vertex 7 is labelled A.

65

70

The resulting labelling is shown in Fig. 10.

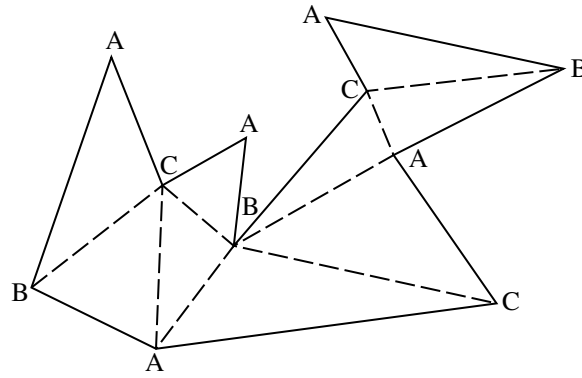

Fig. 10

The 11 vertices have all been assigned a label A, B or C; the numbers of vertices with each label is given in Table 11.

Label	Number of vertices assigned this label
A	5
B	3
C	3

Table 11

Since every triangle contains a vertex labelled A, positioning a camera at each vertex A will ensure that the whole gallery can be observed. This would require 5 cameras. 75

Alternatively, positioning cameras at the 3 vertices labelled B would ensure that the whole gallery can be observed using only 3 cameras.

Positioning cameras at the 3 vertices labelled C would also be sufficient.

Since $\frac{11}{3} < 4$, in any 11-sided polygon at least one of A, B or C must appear as a label at most 3 times. 80

A generalisation of this argument demonstrates that an open-plan gallery with n walls can be covered with $\left\lfloor \frac{n}{3} \right\rfloor$ cameras or fewer. Table 12 shows this information.

n	3	4	5	6	7	8	9	10	11	12	13	14	15
$\left\lfloor \frac{n}{3} \right\rfloor$	1	1	1	2	2	2	3	3	3	4	4	4	5

Table 12

It is always possible to design an open-plan gallery with n walls that requires $\left\lfloor \frac{n}{3} \right\rfloor$ cameras.

Triangulation in practice

For a given open-plan gallery, different triangulations may suggest different numbers of cameras. 85

Figs 13a and 13b show two different triangulations on a particular hexagon. Fig. 13a shows that the whole gallery can be observed using 2 cameras (as in Table 12). However, Fig. 13b shows that only one camera is necessary.

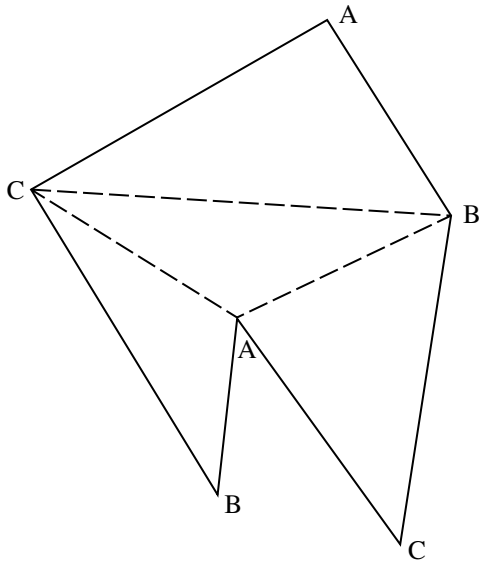

Fig. 13a

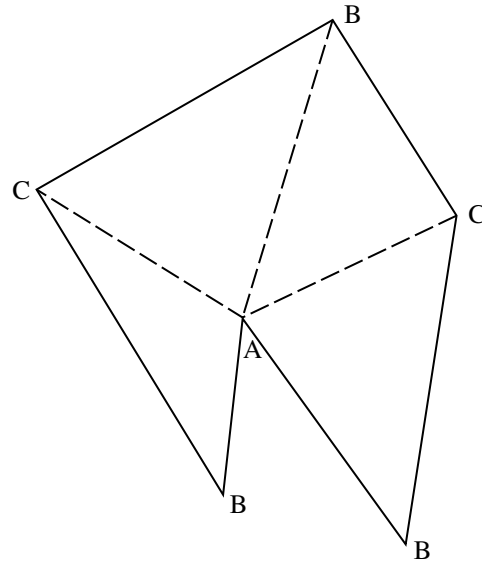

Fig. 13b

Surveillance of the outside of a building

Fig. 14 shows a pentagonal building with corners numbered, in order, from 1 to 5. To observe all of the outside of this building, 3 cameras could be positioned at the odd-numbered corners as shown. 90

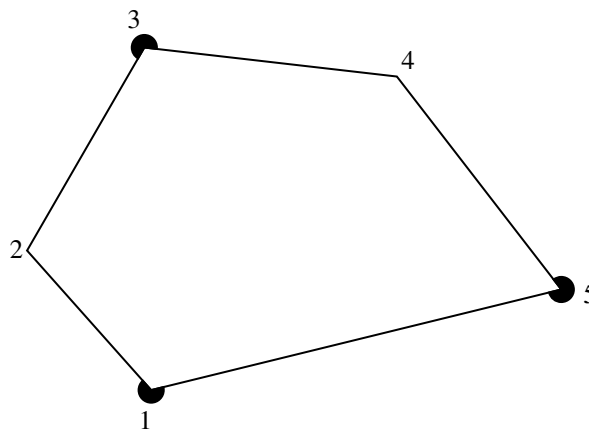

Fig. 14

This method of positioning cameras at odd-numbered corners can be extended to a polygonal building with any number of walls, showing that $\left\lfloor \frac{n+1}{2} \right\rfloor$ cameras are sufficient to observe all the outside of any n -sided polygonal building. 95

If the cameras did not need to be mounted on the walls, but could be positioned further away from the building, then fewer cameras would usually suffice.

Conclusion

Triangulation provides an elegant proof when analysing the minimum number of cameras needed in open-plan galleries. With more complex layouts in two and three dimensions, such elegant solutions have not been discovered although some necessary and some sufficient conditions have been found. In general, optimal solutions are found by applying computer algorithms to mathematical models of galleries.

100

**ADVANCED GCE
MATHEMATICS (MEI)**

4754B

Applications of Advanced Mathematics (C4) Paper B: Comprehension

Candidates answer on the question paper.

OCR supplied materials:

- Insert (inserted)
- MEI Examination Formulae and Tables (MF2)

Other materials required:

- Scientific or graphical calculator
- Rough paper

**Monday 13 June 2011
Morning**

Duration: Up to 1 hour



Candidate forename		Candidate surname	
-----------------------	--	----------------------	--

Centre number						Candidate number				
---------------	--	--	--	--	--	------------------	--	--	--	--

INSTRUCTIONS TO CANDIDATES

- The insert will be found in the centre of this document.
- Write your name, centre number and candidate number in the boxes above. Please write clearly and in capital letters.
- Write your answer to each question in the space provided. Additional paper may be used if necessary but you must clearly show your candidate number, centre number and question number(s).
- Use black ink. Pencil may be used for graphs and diagrams only.
- Read each question carefully. Make sure you know what you have to do before starting your answer.
- Answer **all** the questions.
- Do **not** write in the bar codes.
- The insert contains the text for use with the questions.
- You are permitted to use a scientific or graphical calculator in this paper.
- Final answers should be given to a degree of accuracy appropriate to the context.

INFORMATION FOR CANDIDATES

- The number of marks is given in brackets [] at the end of each question or part question.
- You may find it helpful to make notes and do some calculations as you read the passage.
- You are **not** required to hand in these notes with your question paper.
- You are advised that an answer may receive **no marks** unless you show sufficient detail of the working to indicate that a correct method is being used.
- The total number of marks for this paper is **18**.
- This document consists of **4** pages. Any blank pages are indicated.

- 1** In lines 59 and 60, the text says “In that case the proportion suffering such an attack would be 6.4%.”

Explain how this figure was obtained.

[1]

1	

- 2** (i) In lines 8 to 10, the article says “Some banks do not allow numbers that begin with zero, numbers in which the digits are all the same (such as 5555) or numbers in which the digits are consecutive (such as 2345 or 8765).”

How many different 4-digit PINs can be made when all these rules are applied?

[3]

- (ii) At the time of writing, the world population is 6.7×10^9 people. Assuming that, on average, each person has one card with a 4-digit PIN (subject to the rules in part (i) of this question), estimate the average number of people holding cards with any given PIN. Give your answer to an appropriate degree of accuracy.

[2]

2 (i)	
2 (ii)	

- 3 In lines 46 and 47, the text says “Of the 11 people with unauthorised transactions, 3 could explain them as breaches of card security (typically losing the card) but 9 could not”

Place numbers in the three regions of the diagram consistent with the information in this sentence.

[2]

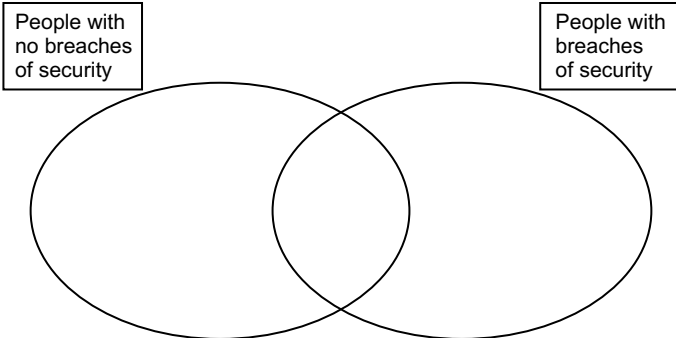
3	
----------	--

- 4 In lines 101 and 102, the text says “The total number of transactions for those who responded has been estimated as 100 000 for the 3½ years covered by the survey.”

Estimate the number of transactions per person per day that would give this figure.

[2]

4	

- 5 The survey described in the article was based on a small sample.

State one conclusion which is unlikely to be influenced by the size of the sample.

[1]

5	

6 A bank has detection software that can be set at two different levels, ‘Mild’ and ‘Severe’.

- When it is set at Mild, 0.1% of all transactions are queried.
- When it is set at Severe 0.5% of all transactions are queried.

(i) One day the bank has 500 000 transactions.

The software is set on ‘Mild’. There are 480 false positives. Only $\frac{1}{3}$ of the unauthorised transactions are queried. Complete the table. [3]

(ii) What is the ratio of false positives to false negatives? [1]

(iii) If the software had been set on ‘Severe’ for the same set of 500 000 transactions, with the total numbers of authorised and unauthorised transactions the same as in part (i) of this question, the number of false negatives would have been 5. What would the ratio of false positives to false negatives have been with this setting? [3]

6 (i)	<table border="1" style="margin-left: auto; margin-right: auto; border-collapse: collapse;"> <thead> <tr> <th style="padding: 5px;">Transactions</th> <th style="padding: 5px;">Authorised</th> <th style="padding: 5px;">Unauthorised</th> <th style="padding: 5px;">Total</th> </tr> </thead> <tbody> <tr> <td style="padding: 5px; text-align: center;">Queried</td> <td style="width: 100px;"></td> <td style="width: 100px;"></td> <td style="width: 100px;"></td> </tr> <tr> <td style="padding: 5px; text-align: center;">Not queried</td> <td></td> <td></td> <td></td> </tr> <tr> <td style="padding: 5px; text-align: center;">Total</td> <td></td> <td></td> <td style="text-align: center;">500 000</td> </tr> </tbody> </table>	Transactions	Authorised	Unauthorised	Total	Queried				Not queried				Total			500 000
Transactions	Authorised	Unauthorised	Total														
Queried																	
Not queried																	
Total			500 000														
6 (ii)																	
6 (iii)																	
	<p>[A copy of the table is provided below for your working.]</p> <table border="1" style="margin-left: auto; margin-right: auto; border-collapse: collapse;"> <thead> <tr> <th style="padding: 5px;">Transactions</th> <th style="padding: 5px;">Authorised</th> <th style="padding: 5px;">Unauthorised</th> <th style="padding: 5px;">Total</th> </tr> </thead> <tbody> <tr> <td style="padding: 5px; text-align: center;">Queried</td> <td style="width: 100px;"></td> <td style="width: 100px;"></td> <td style="width: 100px;"></td> </tr> <tr> <td style="padding: 5px; text-align: center;">Not queried</td> <td></td> <td style="text-align: center;">5</td> <td></td> </tr> <tr> <td style="padding: 5px; text-align: center;">Total</td> <td></td> <td></td> <td style="text-align: center;">500 000</td> </tr> </tbody> </table>	Transactions	Authorised	Unauthorised	Total	Queried				Not queried		5		Total			500 000
Transactions	Authorised	Unauthorised	Total														
Queried																	
Not queried		5															
Total			500 000														

**ADVANCED GCE
MATHEMATICS (MEI)**

4754B

Applications of Advanced Mathematics (C4) Paper B: Comprehension

INSERT

**Monday 13 June 2011
Morning**

Duration: Up to 1 hour

INFORMATION FOR CANDIDATES

- This insert contains the text for use with the questions.
- This document consists of **8** pages. Any blank pages are indicated.

INSTRUCTION TO EXAMS OFFICER / INVIGILATOR

- Do not send this insert for marking; it should be retained in the centre or destroyed.

Card safety

A court case

In a recent (2009) court case, a man claimed that his bank owed him £2100. The money had been taken from his bank account in eight withdrawals from two cash machines, apparently using his bank card, but he said that he had neither made these withdrawals himself nor asked anyone else to make them. His card used chip and PIN technology. The bank had refused to refund his money. 5

The letters PIN stand for Personal Identification Number and refer to a 4-digit number that is needed to authorise transactions using the card, such as withdrawing money. Some banks do not allow numbers that begin with zero, numbers in which the digits are all the same (such as 5555) or numbers in which the digits are consecutive (such as 2345 or 8765). 10

When a bank issues you with a card, various security conditions come with it.

- You are not allowed to tell anyone the PIN.
- You are not allowed to write the PIN down; you must remember it.
- You may not lend the card to anyone else.
- If you lose the card, you must report the loss to the bank. 15

In the 2009 court case, there was no dispute that the withdrawals had taken place. The question was which of the following possible explanations was correct.

1. The man was making a dishonest claim. If so, the man is clearly at fault.
2. The bank had made an error, for example by taking money from this man's account by mistake, and so is at fault. 20
3. A breach of the card's security conditions, as stated above, had allowed a thief to withdraw the money. If so, the man is legally at fault.
4. A thief had been able to withdraw the money without a breach of the card's security conditions. If so, the fault lies with the bank's systems.

Two of these explanations (1 and 3) say that the man is at fault; the other two (2 and 4) put the blame on the bank. 25

Explanations 3 and 4 involve successful 'attacks' by a thief.

The judge decided in favour of the bank. His written judgment caused some people concern. Part of it could be read as meaning that chip and PIN technology is absolutely secure; if so, it would imply that it is impossible for a thief to copy, or 'clone', someone else's card or to break a bank's security. 30

A survey of card users

Following this judgment, MEI conducted a small survey to provide information about the situation, and particularly the four possible explanations. Those taking part were mathematics teachers attending a conference in June 2009; 250 questionnaires were given out and 80 returned. The survey was based on people's experience with their banks. 35

Banks use software designed to detect suspicious transactions; if one is detected, the bank usually contacts the card-holder to check whether the transaction should go ahead. The survey asked people whether they had been contacted by their banks about a suspicious transaction.

If the answer was Yes, they were then asked to answer a further question as to whether they had 40

authorised the transaction. An answer of Yes to this further question meant that the transaction was genuine, and an answer of No that an attack had been detected.

- 46 of the 80 respondents had been contacted by their banks, many of them several times.
- Most of the transactions had in fact been authorised, but 11 of the 46 people had been contacted about unauthorised transactions. 45
- Of the 11 people with unauthorised transactions, 3 could explain them as breaches of card security (typically losing the card) but 9 could not (one person was in both categories).

The survey then went on to ask about cases that had not been picked up by the banks' detection software, resulting in unauthorised withdrawals from people's accounts.

- 21 people reported unauthorised withdrawals. 50
- Of these, 9 people could explain them as breaches of card security and 13 could not (again one person was in both categories).

In total, 16 out of the 80 people who responded to the survey had been the subject of attacks in which there was no breach of the card's security conditions. Some of the attacks had been stopped by their banks but others had resulted in money being withdrawn from their accounts; some people reported both of these. If the survey results are reasonably representative, they would suggest that, in the course of the $3\frac{1}{2}$ years covered by the survey, 20% of people had suffered an attack without any breach of their cards' security. This may be an overestimate. Only 80 out of 250 people returned the questionnaire; maybe all the 170 who did not return it had nothing to report. In that case the proportion suffering such an attack would be 6.4%. 55
60

The conclusion that attacks can happen without breaches of card security is supported by the fact that banks are prepared to bear the considerable costs that must be involved in the process of carrying out checks.

Possible explanations

In a typical court case involving card security, the claimant has had money withdrawn from an account and the bank has refused to refund it. There is no dispute that the withdrawal has taken place. The four possible explanations on the first page apply and the results from the survey make it possible to say something about them. 65

In the first explanation, it is the claimant who has withdrawn the money and is then saying it was someone else. The survey suggests that the other explanations are also possible. Whether the court judges the claimant to be telling the truth must depend on other evidence. 70

The next possible explanation is that the bank made an error, and this can happen. One of the responses to the questionnaire said

“We went to the bank and spoke at length with the manager. We were fully reimbursed and had a grovelling apology.” 75

That leaves the two explanations that involve the money being taken by a thief, with or without a breach of the card's security. The survey also identified the number of transactions, as well as the number of people, subject to attacks. There were a total of 42 attacks; several people reported more than one attack. 13 of the attacks could be explained by breaches of card security and 29 could not.

So the data would suggest that, if there has been an attack, the probabilities of the two explanations of breach and no breach of card security are $\frac{13}{42}$ and $\frac{29}{42}$. These figures are based on a small sample and so it would be better to think of them as about $\frac{1}{3}$ and $\frac{2}{3}$. In civil cases, courts decide the outcome on a 'balance of probabilities'. The probabilities of $\frac{1}{3}$ and $\frac{2}{3}$ are so close together that a court would 80

be unwilling to decide the matter on the basis of them alone, and would look for other evidence before reaching a decision.

85

The banks

The survey went on to ask those who reported unauthorised withdrawals what happened next. In nearly all cases the bank had refunded the money but in one case this had not happened.

One of the responses to the questionnaire said

“The bank described two transactions in the space of 3 or 4 hours. One for about £40 in a shop in London and the other for over £500 at an expensive restaurant/club in London. I was in Paris at the time of these transactions. The bank refunded both amounts after I filled in a form. ... I assume that someone had managed to clone my card somehow.”

90

Clearly fraud can cost the banks a lot of money.

95

If a bank refuses to pay, the next course of action open to someone who has lost money in this way is to contact the independent Financial Ombudsman. A few of these cases are then taken further and end up in court.

Detecting fraud

The survey provided information about the banks' success in detecting unauthorised transactions. The total number of transactions for those who responded has been estimated as 100 000 for the 3½ years covered by the survey. Table 1 shows data from the survey and, in brackets, figures derived from the estimate of 100 000 transactions.

100

Transactions	Authorised	Unauthorised	Total
Queried	139	19	158
Not queried	(99 819)	23	(99 842)
Total	(99 958)	42	(100 000)

Table 1

Table 1 illustrates the problems faced by the banks. They check a very large number of transactions, query quite a small proportion of them and succeed in stopping a small number of unauthorised transactions. However, despite all this effort, the figures in Table 1 suggest that they only catch about half of the attacks.

105

The entries in a table like this are often described using the terms in Table 2.

Transactions	Authorised	Unauthorised
Queried	False positives	True positives
Not queried	True negatives	False negatives

Table 2

A 'positive' is a transaction that is identified by a bank's computer software as suspect and so is queried. The identification is 'false' if the transaction was in fact authorised and it is 'true' if the transaction was unauthorised. 110

Similarly, a 'negative' is a transaction that is not identified as suspect and this non-identification may be true or false.

So, if the software gives a warning when there is no attack, a false positive results; 139 of these are recorded in Table 1 and, apart from some inconvenience, they are quite harmless. If, however, the software fails to give a warning when there really is an attack, a false negative occurs, resulting in unauthorised withdrawals and these are the serious cases; there are 23 of them in Table 1. 115

The number of false negatives can be reduced by making the warning criteria in the software more severe, but the effect will inevitably be that the number of false positives rises: the more severe warning criteria will pick out more authorised transactions. Thus the fewer the false negatives, the greater the number of false positives, and vice-versa. 120

The detection software may be thought of as the front line in the ongoing struggle between thieves and banks. Once thieves learn how it is programmed, they can find ways to defeat it. Consequently the information is considered to be top secret by the banks.

Finally, a piece of advice. Never let anyone else use your card. Legally, your PIN is an electronic signature and so allowing someone else to use it is the equivalent of telling them to forge your signature. 125

BLANK PAGE

BLANK PAGE

**Copyright Information**

OCR is committed to seeking permission to reproduce all third-party content that it uses in its assessment materials. OCR has attempted to identify and contact all copyright holders whose work is used in this paper. To avoid the issue of disclosure of answer-related information to candidates, all copyright acknowledgements are reproduced in the OCR Copyright Acknowledgements Booklet. This is produced for each series of examinations and is freely available to download from our public website (www.ocr.org.uk) after the live examination series.

If OCR has unwittingly failed to correctly acknowledge or clear any third-party content in this assessment material, OCR will be happy to correct its mistake at the earliest possible opportunity.

For queries or further information please contact the Copyright Team, First Floor, 9 Hills Road, Cambridge CB2 1GE.

OCR is part of the Cambridge Assessment Group; Cambridge Assessment is the brand name of University of Cambridge Local Examinations Syndicate (UCLES), which is itself a department of the University of Cambridge.

Thursday 14 June 2012 – Morning

A2 GCE MATHEMATICS (MEI)

4754 Applications of Advanced Mathematics (C4)

INSTRUCTIONS



The examination is in two parts:

Paper A (1 hour 30 minutes)

Paper B (up to 1 hour)

Supervisors are requested to ensure that Paper B **is not issued** until Paper A has been collected in from the candidates.

Centres may, if they wish, grant a supervised break between the two parts of this examination.

Paper B should not be attached to the corresponding paper A script. For Paper A only the candidates' printed answer books, in the same order as the attendance register, should be sent for marking; the question paper should be retained in the centre or recycled. For Paper B only the question papers, on which the candidates have written their answers, should be sent for marking; the insert should be retained in the centre or recycled. Any additional sheets used must be carefully attached to the correct paper.

For Paper B (Comprehension) only.

A standard English dictionary is allowed for the comprehension.

(Dictionaries to be used in the examination must be thoroughly checked before the examination.) Full regulations are in the JCQ Regulations and Guidance booklet.

This notice must be on the Invigilator's desk at all times during the morning of Thursday 14 June 2012.

Thursday 14 June 2012 – Morning

A2 GCE MATHEMATICS (MEI)

4754B Applications of Advanced Mathematics (C4) Paper B: Comprehension

Candidates answer on the Question Paper.

OCR supplied materials:

- Insert (inserted)
- MEI Examination Formulae and Tables (MF2)

Other materials required:

- Scientific or graphical calculator
- Rough paper

Duration: Up to 1 hour



Candidate forename		Candidate surname	
--------------------	--	-------------------	--

Centre number						Candidate number				
---------------	--	--	--	--	--	------------------	--	--	--	--

INSTRUCTIONS TO CANDIDATES

- The Insert will be found in the centre of this document.
- Write your name, centre number and candidate number in the boxes above. Please write clearly and in capital letters.
- Use black ink. HB pencil may be used for graphs and diagrams only.
- Answer **all** the questions.
- Read each question carefully. Make sure you know what you have to do before starting your answer.
- Write your answer to each question in the space provided. Additional paper may be used if necessary but you must clearly show your candidate number, centre number and question number(s).
- Do **not** write in the bar codes.
- The Insert contains the text for use with the questions.
- You are permitted to use a scientific or graphical calculator in this paper.
- Final answers should be given to a degree of accuracy appropriate to the context.

INFORMATION FOR CANDIDATES

- The number of marks is given in brackets [] at the end of each question or part question.
- You may find it helpful to make notes and to do some calculations as you read the passage.
- You are **not** required to hand in these notes with your Question Paper.
- You are advised that an answer may receive **no marks** unless you show sufficient detail of the working to indicate that a correct method is being used.
- The total number of marks for this paper is **18**.
- This document consists of **8** pages. Any blank pages are indicated.

- 1 Use Fig. 4 to estimate the number of 50–54 year olds in the UK in 2001. (These were born in the post World War 2 baby boom.) [1]

1	

- 2 A copy of Fig. 2 is given below.

- (i) Join the points with a curve and hence estimate the rate of population growth in the year 1927 in people per year. [3]

- (ii) Estimate this rate as a percentage of the population at that time. [2]

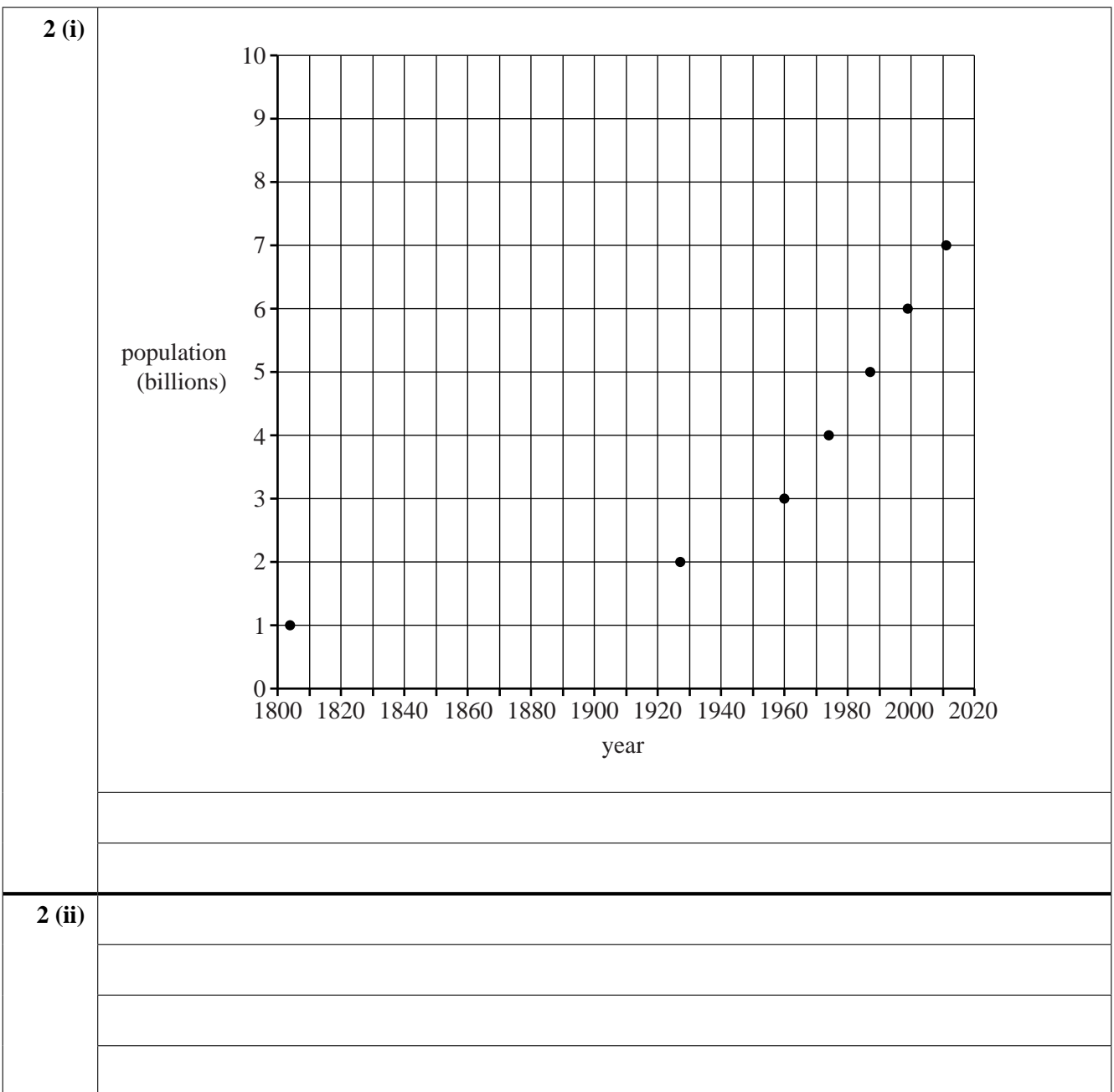

3 (i) In line 21, the solution of the differential equation $\frac{dp}{dt} = kp$ is stated to be $p = p_0 e^{kt}$.

Use integration to derive this result.

[3]

(ii) The article then goes on to say

“If a model is to be valuable in this context, it must be possible to use it to predict the size of the world population in the future. So, as a test case, the first two data points in Table 1 should allow the later values to be predicted. These data points are

$$1804 \quad t = 0, p = p_0 = 10^9,$$

$$1927 \quad t = 123, p = 2 \times 10^9,$$

and these correspond to $k = 0.00563 \dots$.”

Show how this value of k is obtained.

[2]

3 (i)	
3 (ii)	

4 In Table 6, the population profile of an imaginary country was predicted. Complete the table subject to the same general assumptions except that, after 2010:

- the average number of children per female is 2.2;
- 60% of those in the 40–59 age group survive into the 60–79 age group;
- 20% of those in the 60–79 age group survive into the 80+ age group.

[3]

4	<table border="1" style="margin: auto; border-collapse: collapse;"> <thead> <tr> <th style="padding: 5px;">Age group</th> <th style="padding: 5px;">2010</th> <th style="padding: 5px;">2030</th> <th style="padding: 5px;">2050</th> <th style="padding: 5px;">2070</th> </tr> </thead> <tbody> <tr> <td style="text-align: center; padding: 5px;">80+</td> <td style="text-align: center; padding: 5px;">1</td> <td style="padding: 5px;"></td> <td style="padding: 5px;"></td> <td style="padding: 5px;"></td> </tr> <tr> <td style="text-align: center; padding: 5px;">60–79</td> <td style="text-align: center; padding: 5px;">10</td> <td style="padding: 5px;"></td> <td style="padding: 5px;"></td> <td style="padding: 5px;"></td> </tr> <tr> <td style="text-align: center; padding: 5px;">40–59</td> <td style="text-align: center; padding: 5px;">20</td> <td style="padding: 5px;"></td> <td style="padding: 5px;"></td> <td style="padding: 5px;"></td> </tr> <tr> <td style="text-align: center; padding: 5px;">20–39</td> <td style="text-align: center; padding: 5px;">20</td> <td style="padding: 5px;"></td> <td style="padding: 5px;"></td> <td style="padding: 5px;"></td> </tr> <tr> <td style="text-align: center; padding: 5px;">0–19</td> <td style="text-align: center; padding: 5px;">20</td> <td style="padding: 5px;"></td> <td style="padding: 5px;"></td> <td style="padding: 5px;"></td> </tr> <tr> <td style="text-align: center; padding: 5px;">Total</td> <td style="text-align: center; padding: 5px;">71</td> <td style="padding: 5px;"></td> <td style="padding: 5px;"></td> <td style="padding: 5px;"></td> </tr> </tbody> </table>	Age group	2010	2030	2050	2070	80+	1				60–79	10				40–59	20				20–39	20				0–19	20				Total	71			
Age group	2010	2030	2050	2070																																
80+	1																																			
60–79	10																																			
40–59	20																																			
20–39	20																																			
0–19	20																																			
Total	71																																			
	As in Table 6, the figures are in millions.																																			

5 In constructing Table 6, some assumptions were made about the proportion of people surviving from one age group to the next. Use Table 6 to find

- (i) the proportion of people in the 40–59 age group surviving into the 60–79 age group, [1]
- (ii) the proportion of those in the 60–79 age group surviving into the 80+ age group. [1]

5 (i)	
5 (ii)	

6 This table refers to the UK. It gives life expectancy and birth rate every 20 years from 1901 to 2001.

Year	Life expectancy	Birth rate (births/1000)
1901	47	28.5
1921	58	22.7
1941	64	14.5
1961	71	17.8
1981	74	12.9
2001	78	12.0

Explain how these data relate to the conclusions of the article.

[2]

[A copy of Fig. 7 is given below. You do not need to use it but may find it helpful.]

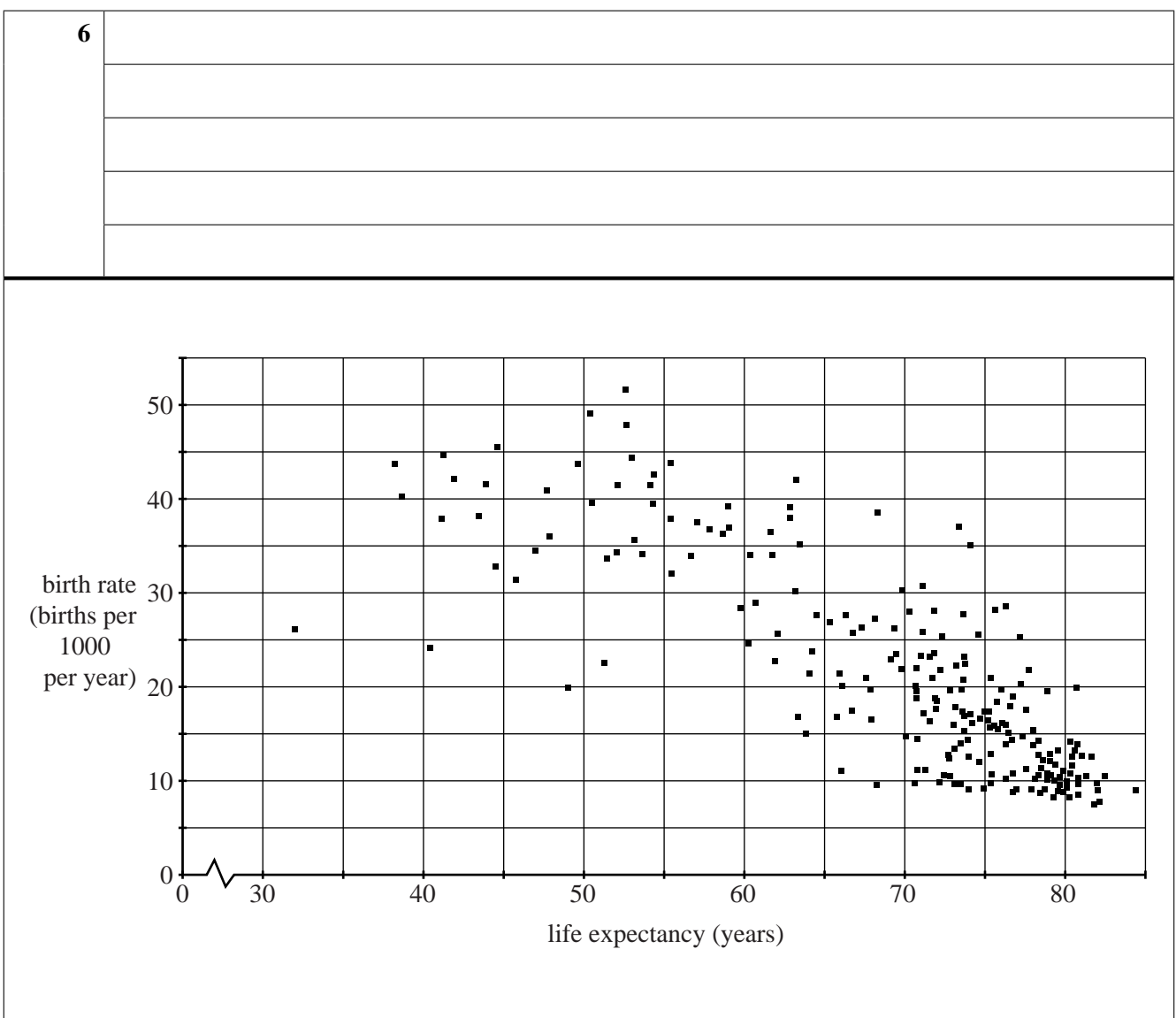

BLANK PAGE

PLEASE DO NOT WRITE ON THIS PAGE

BLANK PAGE

PLEASE DO NOT WRITE ON THIS PAGE

PLEASE DO NOT WRITE ON THIS PAGE



Copyright Information

OCR is committed to seeking permission to reproduce all third-party content that it uses in its assessment materials. OCR has attempted to identify and contact all copyright holders whose work is used in this paper. To avoid the issue of disclosure of answer-related information to candidates, all copyright acknowledgements are reproduced in the OCR Copyright Acknowledgements Booklet. This is produced for each series of examinations and is freely available to download from our public website (www.ocr.org.uk) after the live examination series.

If OCR has unwittingly failed to correctly acknowledge or clear any third-party content in this assessment material, OCR will be happy to correct its mistake at the earliest possible opportunity.

For queries or further information please contact the Copyright Team, First Floor, 9 Hills Road, Cambridge CB2 1GE.

OCR is part of the Cambridge Assessment Group; Cambridge Assessment is the brand name of University of Cambridge Local Examinations Syndicate (UCLES), which is itself a department of the University of Cambridge.

Thursday 14 June 2012 – Morning

A2 GCE MATHEMATICS (MEI)

4754B Applications of Advanced Mathematics (C4) Paper B: Comprehension

INSERT

INFORMATION FOR CANDIDATES

- This Insert contains the text for use with the questions.
- This document consists of **8** pages. Any blank pages are indicated.

INSTRUCTION TO EXAMS OFFICER/INVIGILATOR

- Do not send this Insert for marking; it should be retained in the centre or recycled. Please contact OCR Copyright should you wish to re-use this document.

The world population

Population pressure on our planet

During the last 200 years, the human population has increased by a factor of about 7. Table 1 gives the years when it reached 1, 2, 3 and so on billions of people, where 1 billion is 10^9 .

Year	1804	1927	1960	1974	1987	1999	2011
Population (billions)	1	2	3	4	5	6	7

Table 1 World population

The increase in population is placing rising demands on the resources of our planet and on the whole eco-system that supports us. This raises very important questions. 5

- Is the world's population going to continue to increase indefinitely or will there be a limit?
- Will the world's population reach a level that the planet is unable to support?
- Should we be taking measures to restrict the world's population, and if so what?

The first two of these questions require mathematical modelling of the situation. The third involves political and ethical decisions which should be informed by that modelling. 10

The modelling involved is complicated; this article introduces some of the issues involved.

The exponential model

A simple mathematical model is that the world's population is increasing at a rate which is directly proportional to its existing size, 15

$$\frac{dp}{dt} = kp,$$

where p is the number of people,
 t is time, measured in years,
 k is a constant.

The solution of this differential equation is 20

$$p = p_0 e^{kt}$$

where p_0 is the population at the time from which t is measured.

If a model is to be valuable in this context, it must be possible to use it to predict the size of the world population in the future. So, as a test case, the first two data points in Table 1 should allow the later values to be predicted. These data points are 25

$$\begin{aligned} 1804 & \quad t = 0, p = p_0 = 10^9, \\ 1927 & \quad t = 123, p = 2 \times 10^9, \end{aligned}$$

and these correspond to $k = 0.00563 \dots$

With this value of k , this model would predict that the population in 2011 would be 3.2 billion but in fact it was 7 billion. This model, based on the first two data points, is clearly not suitable.

30

In fact no exponential model fits the data in Table 1 well. You can see this just by looking at the graph of the data in Fig. 2. The graph of an exponential function is a curve which gets steeper and steeper but for the last 50 years this graph is virtually a straight line, indicating a constant rate of growth.

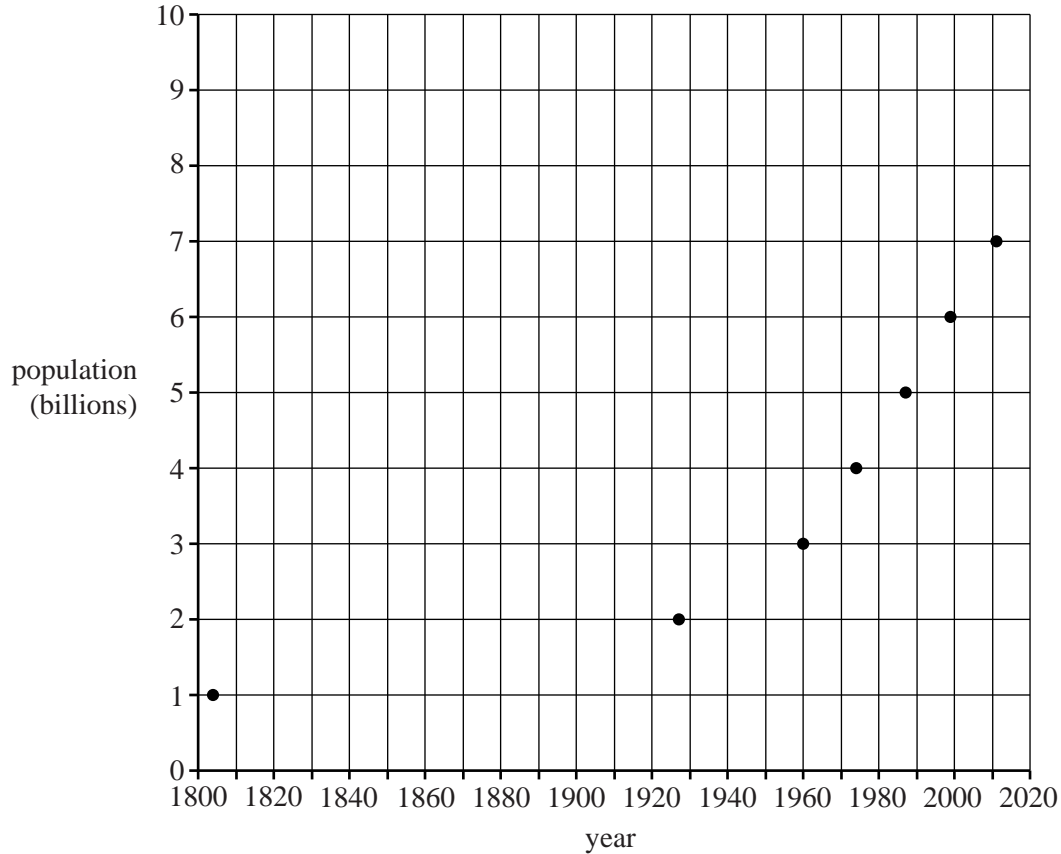

Fig. 2 World population from 1800 to the present

The logistic model

A standard mathematical model for a population which increases towards a limiting value of m is given by the differential equation

35

$$\frac{dp}{dt} = kp(m - p).$$

This is known as the *logistic equation*. A typical solution curve is shown in Fig. 3.

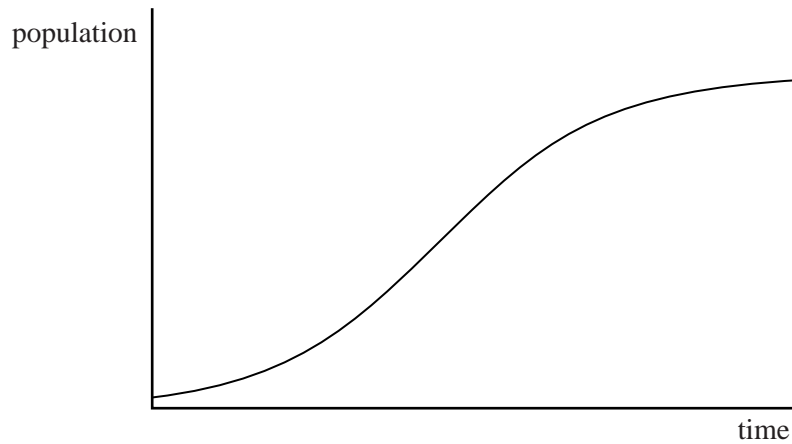

Fig. 3 The logistic model

While this looks as though it starts with the same sort of shape as a curve through the data points in Fig. 2, the resemblance is only superficial; it is not actually possible to find values of k and m that produce anything like a good fit. So this model is also unsatisfactory.

40

Like the previous model, this is an attempt to find a simple, neat solution to a very complicated problem. A different approach is needed and a starting point is provided by population profiles.

Population profiles

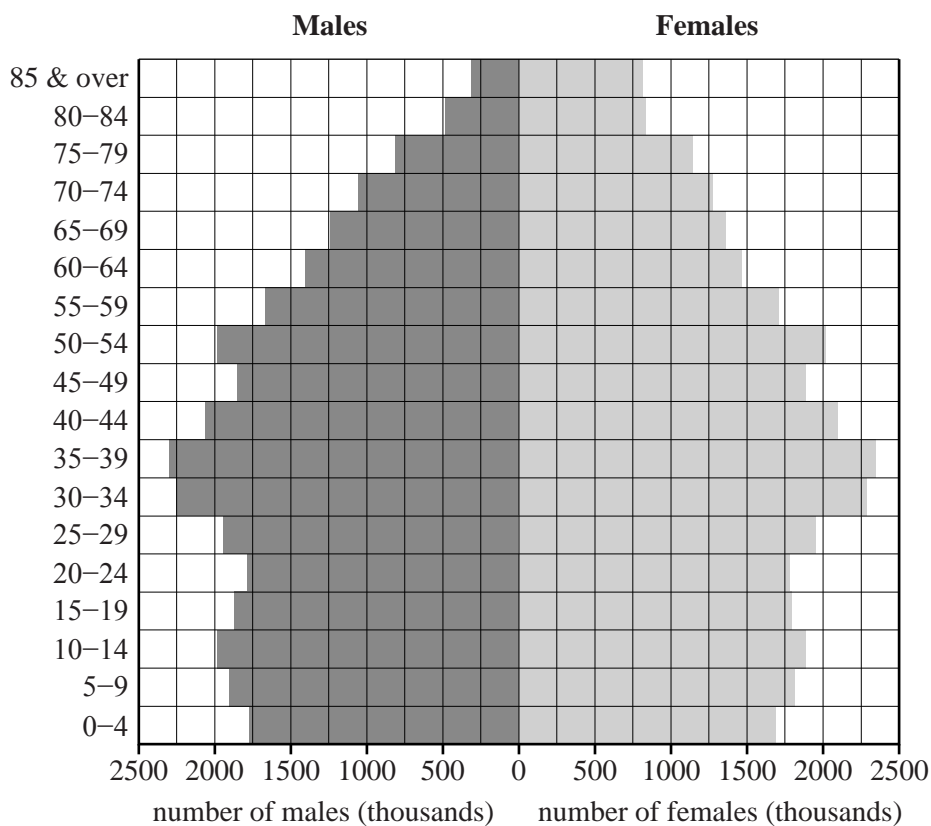

Fig. 4 Population profile of the UK in 2001

Population profiles are often illustrated by population pyramids, like that in Fig. 4. The lengths of the horizontal bars indicate the numbers of males and females in the UK population in 2001, in 5-year age intervals. In this case, the numbers on the horizontal scale are in thousands. Those on the vertical scale refer to age in completed years so that, for example, 10–14 means from 10 years 0 days to 14 years 364 days. 45

The UK population profile shows that in 2001 the number of children in the 0–4 age range was among the lowest for 50 years. Because there are fewer people in that age group, they in turn can be expected to have fewer children. 50

The shapes of the population profiles vary considerably between countries. In some countries the profiles have very wide bases, indicating large numbers of children.

It is worth noting that population figures for the UK are often affected by emigration and immigration. 55

Modelling using population profiles

If the individual population profiles of the large number of countries in the world are combined, a profile for the whole world emerges. It is possible to predict the changes in any country's profile in the years ahead, and hence the changes in the world's population. Each country is different and so needs to be looked at separately before combining the profiles. 60

The following model, for an imaginary country, is designed to highlight the key factors. Table 5 illustrates its profile in 2010 and part of that for 2030.

Age group	2010		2030
80+	1		?
60–79	10		?
40–59	20		20
20–39	20		20
0–19	20		?
Total	71		?

Table 5 Population profile of an imaginary country (in millions)

In 2010, this country has a stable population with the same numbers in the youngest three age groups, up to the age of 60; however, life expectancy is quite low with very few people reaching the age of 80.

Two of the figures for 2030 have also been filled in. The 20 million people in the 0–19 age group in 2010 will move into the 20–39 group. Similarly those in the 20–39 group will move into the 40–59 group. (It is assumed, for simplicity, that no one in these age groups dies.) What will the other figures for 2030 be? 65

Two different factors are involved: the birth rate and the life expectancy.

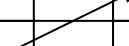
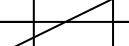
The 2010 profile in Table 5 was constructed using a number of assumptions:

70

- that those in the 0–19 age group are all children of females in the 20–39 group;
- that 50% of those in the 20–39 age group are female;
- that on average each female has 2 children;
- that there is no immigration or emigration.

While these assumptions are obviously somewhat artificial, particularly with regard to the age at which women have children, they are good enough to demonstrate the key features of a country's population.

75

Throughout the world, life expectancy is rising. The proportion of the population in Table 5 who reach the age of 80 could be expected to increase.

In Table 6, the population profile of the country in Table 5 is predicted for the next 100 years, on the basis of the following new assumptions about the birth rate and life expectancy.

80

- Every 20 years, each group of people moves up a level.
- The average figure of 2 children per female is assumed to fall to 1.8, from 2010 onwards.
- The proportion of those in the 40–59 age group surviving into the 60–79 group increases from the 2010 figure of 50%; similarly there is an increase in survival from the 60–79 group into the 80+ group.

85

The figures used in these assumptions have been chosen to illustrate the modelling process. Their use does not mean that they will actually apply to the population of any real country.

Age group	2010	2030	2050	2070	2090	2110
80+	1	4	6.4	6.4	6.4	5.76
60–79	10	16	16	16	14.4	12.96
40–59	20	20	20	18	16.2	14.58
20–39	20	20	18	16.2	14.58	13.12
0–19	20	18	16.2	14.58	13.12	11.81
Total	71	78	76.6	71.18	64.7	58.23

Table 6 Population profile of an imaginary country (in millions, to 4 significant figures)

The figures in Table 6 show the total population rising quite sharply to a maximum and then reducing, initially rather slowly but then more quickly. Patterns like this are observed in many countries. In some, like Japan, the population has passed its maximum and is declining. In most, however, it is still increasing and consequently the population of the world as a whole is still increasing.

90

An important feature of Table 6 is that it is based on a low birth rate of 1.8 children per female. In many countries the birth rate is much higher than the stable level of 2 children per female.

Birth rate and life expectancy

Two key factors that determine the change in a country's population have been identified as its birth rate and its life expectancy. Data show that these are closely associated. Countries with high birth rates tend to have low life expectancy and those with low birth rates have high life expectancy. This is illustrated in Fig. 7 for all 221 countries; the data were drawn from the CIA World Factbook for 2009.

95

Notice that in Fig. 7 the birth rate is the number of births per 1000 of the population per year. It is thus a different measure from that used so far in this article which is mean births per female over her lifetime. So, for example, a country with a population of 80 million people and 1.2 million births per year has a birth rate of 15 births per 1000 per year.

100

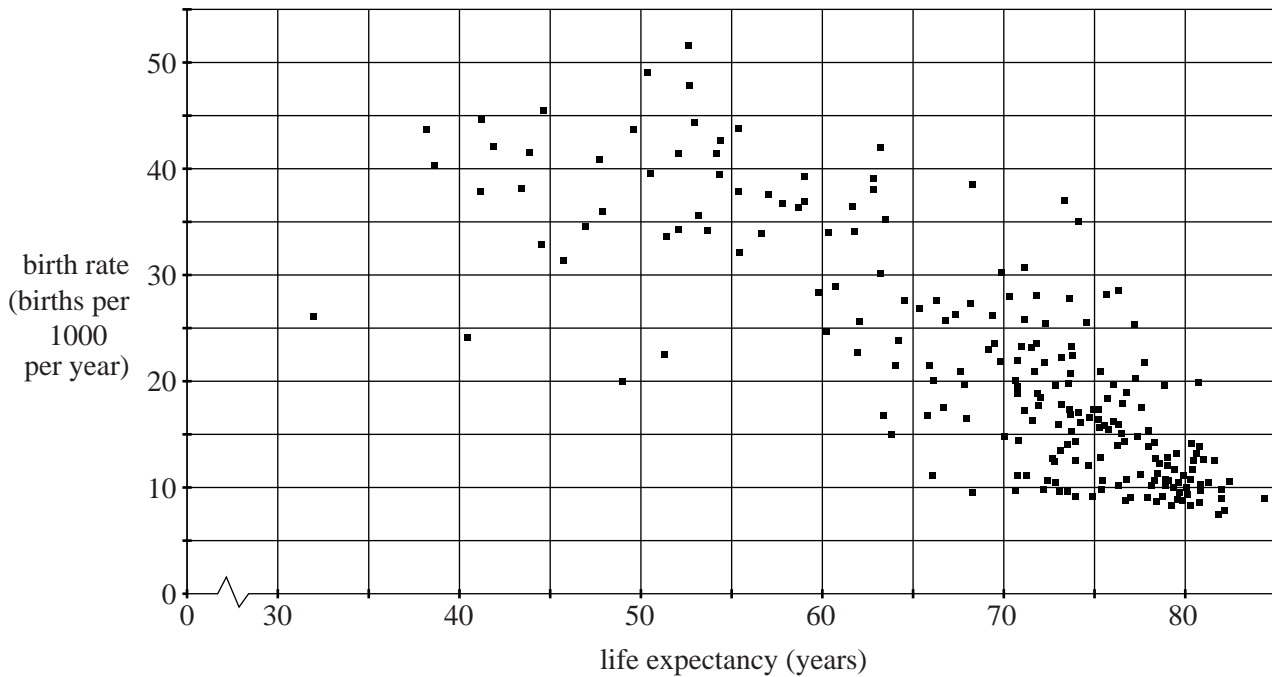

Fig. 7 Scatter diagram showing birth rate against life expectancy for the countries of the world

Conclusion

Table 8 gives the data for some selected countries in 2009.

Country	Life expectancy	Birth rate
Japan	82.12	7.64
Sweden	80.86	10.13
Italy	80.20	8.18
UK	79.01	10.65
USA	78.11	13.82
Tunisia	75.78	15.42
Jamaica	73.53	19.68
China	73.47	14.00
Brazil	71.99	18.43
India	69.89	21.76
Bangladesh	60.25	24.68
Ghana	59.85	28.58
Uganda	52.72	47.84
Afghanistan	44.64	45.46

Table 8 Life expectancy and birth rates of selected countries (2009)

The data in Table 8 illustrate the observation that countries with low birth rate and high life expectancy tend to be those with developed economies. Studies over time indicate that as they develop, countries follow a path from high birth rate and low life expectancy to low birth rate and high life expectancy. So it is reasonable to expect that at some time in the future, the world's population will attain a maximum value and then start to decline. 105

When that maximum occurs, and how great the population then is, will depend on how quickly countries progress along that path. Consequently modelling the world's population requires an understanding of the factors involved. Then it will be possible to determine what can be done to match the population to the planet's resources. 110



Copyright Information

OCR is committed to seeking permission to reproduce all third-party content that it uses in its assessment materials. OCR has attempted to identify and contact all copyright holders whose work is used in this paper. To avoid the issue of disclosure of answer-related information to candidates, all copyright acknowledgements are reproduced in the OCR Copyright Acknowledgements Booklet. This is produced for each series of examinations and is freely available to download from our public website (www.ocr.org.uk) after the live examination series.

If OCR has unwittingly failed to correctly acknowledge or clear any third-party content in this assessment material, OCR will be happy to correct its mistake at the earliest possible opportunity.

For queries or further information please contact the Copyright Team, First Floor, 9 Hills Road, Cambridge CB2 1GE.

OCR is part of the Cambridge Assessment Group; Cambridge Assessment is the brand name of University of Cambridge Local Examinations Syndicate (UCLES), which is itself a department of the University of Cambridge.

Friday 18 January 2013 – Afternoon

A2 GCE MATHEMATICS (MEI)

4754/01 Applications of Advanced Mathematics (C4)

INSTRUCTIONS



The examination is in two parts:

Paper A (1 hour 30 minutes)

Paper B (up to 1 hour)

Supervisors are requested to ensure that Paper B **is not issued** until Paper A has been collected in from the candidates.

Centres may, if they wish, grant a supervised break between the two parts of this examination.

Paper B should not be attached to the corresponding paper A script. For Paper A only the candidates' printed answer books, in the same order as the attendance register, should be sent for marking; the question paper should be retained in the centre or recycled. For Paper B only the question papers, on which the candidates have written their answers, should be sent for marking; the insert should be retained in the centre or recycled. Any additional sheets used must be carefully attached to the correct paper.

For Paper B (Comprehension) only.

A standard English dictionary is allowed for the comprehension.

(Dictionaries to be used in the examination must be thoroughly checked before the examination.) Full regulations are in the JCQ Regulations and Guidance booklet.

This notice must be on the Invigilator's desk at all times during the afternoon of Friday 18 January 2013.

**Copyright Information**

OCR is committed to seeking permission to reproduce all third-party content that it uses in its assessment materials. OCR has attempted to identify and contact all copyright holders whose work is used in this paper. To avoid the issue of disclosure of answer-related information to candidates, all copyright acknowledgements are reproduced in the OCR Copyright Acknowledgements Booklet. This is produced for each series of examinations and is freely available to download from our public website (www.ocr.org.uk) after the live examination series.

If OCR has unwittingly failed to correctly acknowledge or clear any third-party content in this assessment material, OCR will be happy to correct its mistake at the earliest possible opportunity.

For queries or further information please contact the Copyright Team, First Floor, 9 Hills Road, Cambridge CB2 1GE.

OCR is part of the Cambridge Assessment Group; Cambridge Assessment is the brand name of University of Cambridge Local Examinations Syndicate (UCLES), which is itself a department of the University of Cambridge.

Friday 18 January 2013 – Afternoon

A2 GCE MATHEMATICS (MEI)

4754/01B Applications of Advanced Mathematics (C4) Paper B: Comprehension

INSERT

Duration: Up to 1 hour



INFORMATION FOR CANDIDATES

- This insert contains the text for use with the questions.
- This document consists of **8** pages. Any blank pages are indicated.

INSTRUCTION TO EXAMS OFFICER/INVIGILATOR

- Do not send this insert for marking; it should be retained in the centre or recycled. Please contact OCR Copyright should you wish to re-use this document.

Taxicab geometry

Introduction

Fig. 1 shows part of the road map of an imaginary town called Newtown.

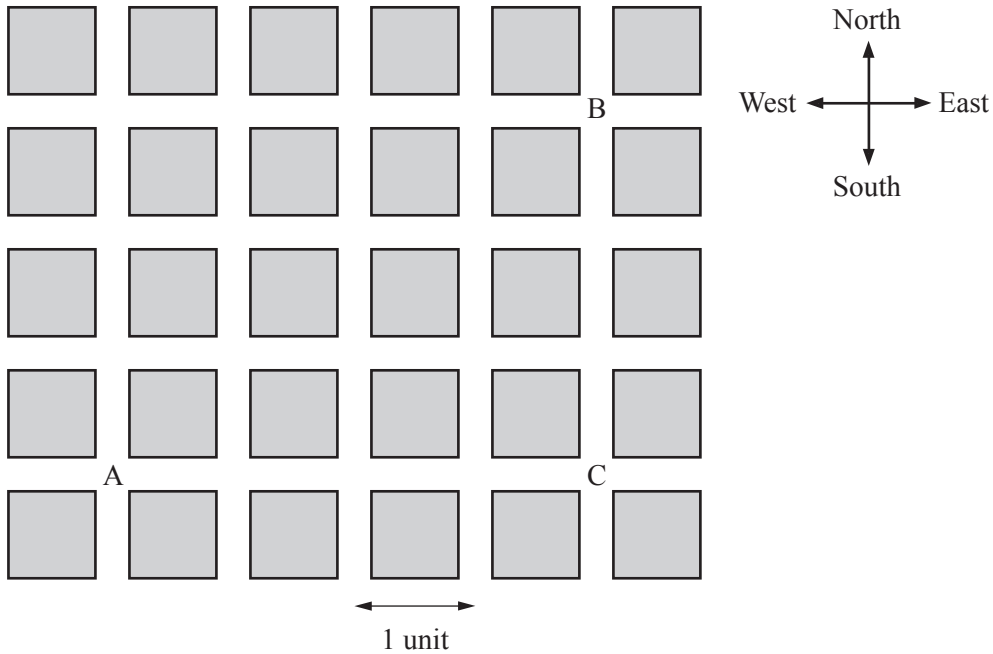

Fig. 1

Newtown's buildings are grouped in equal-sized square blocks. The roads between the blocks run in north-south and east-west directions and traffic can travel along every road in both directions. 5

Imagine you want to take a taxi from point A to point B. If the taxi travelled east from A to C and then north from C to B, the total distance travelled would be 7 units. Many other routes from A to B are also 7 units in length but no route is shorter. This shortest distance is called the *taxicab distance* from A to B and the related mathematics is called *taxicab geometry*.

This article introduces some of the mathematics of taxicab geometry. 10

Introducing the notation

Fig. 2 shows part of the road map of Newtown and one particular bus route with bus stops at positions M and N. Imagine you are at position L and you wish to catch a bus at one of these bus stops. Which is closer?

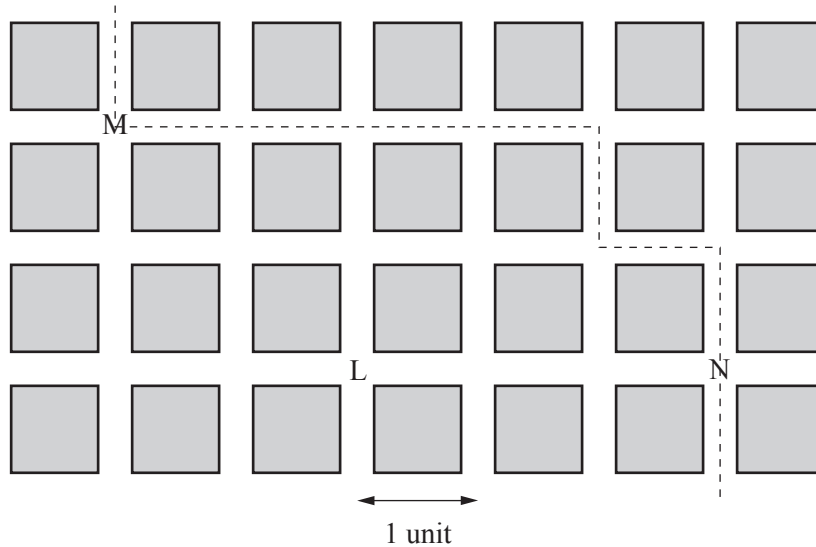

Fig. 2

By Pythagoras's Theorem, the straight line distance, measured in units as shown in Fig. 2, from L to M is $2\sqrt{2}$. This is expressed using the notation $d(L,M) = 2\sqrt{2}$. Similarly, $d(L,N) = 3$. In terms of straight line distances, M is closer than N since $d(L,M) < d(L,N)$. 15

For a pedestrian, who is constrained to walking along roads, it is the taxicab distance rather than the Pythagorean distance that is important. The taxicab distance from L to M is 4. This is expressed using the notation $t(L,M) = 4$. Similarly $t(L,N) = 3$. For a pedestrian at L, since $t(L,N) < t(L,M)$, N is closer than M. 20

This is an example of a situation in which $d(L,M) < d(L,N)$ but $t(L,M) > t(L,N)$.

In general, if the Pythagorean distance between two points A and B is $d(A,B)$ then the taxicab distance satisfies the inequalities $d(A,B) \leq t(A,B) \leq \sqrt{2} \times d(A,B)$.

Minimum distance routes

25

In Fig. 1 the Pythagorean distance between the points A and B is 5. There is only one straight line segment from A to B; its length is 5.

However, this uniqueness property does not hold when considering the taxicab distance. In Fig. 1, the taxicab distance from A to B is 7. There are several routes from A to B which have this minimum distance; these are called *minimum distance routes*.

30

How many minimum distance routes are there from A to B?

In order to answer this question, the road grid is replaced by a coordinate system as shown in Fig. 3. The x -axis represents the west-east direction and the y -axis represents the south-north direction. Point A has coordinates $(0,0)$ and point B has coordinates $(4,3)$. The roads are shown by the grid lines.

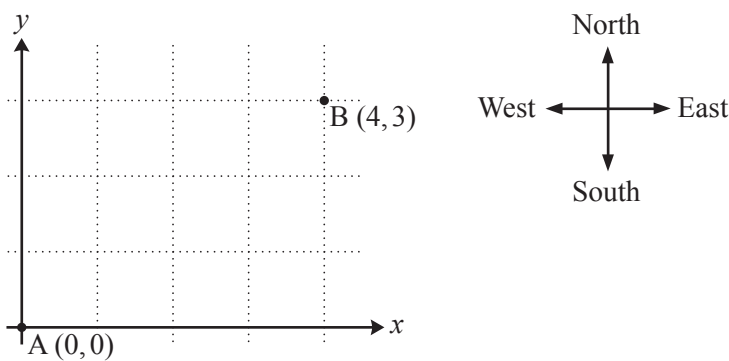

Fig. 3

Clearly, no minimum distance route from A to any point in the first quadrant will involve any motion in a westerly or southerly direction.

35

There is only one minimum distance route from A to any point on the x -axis or to any point on the y -axis.

There are two ways of reaching the point with coordinates $(1,1)$ along minimum distance routes as follows.

$$(0,0) \rightarrow (1,0) \rightarrow (1,1)$$

$$(0,0) \rightarrow (0,1) \rightarrow (1,1)$$

40

The numbers of minimum distance routes from A to the points mentioned above are shown in Fig. 4.

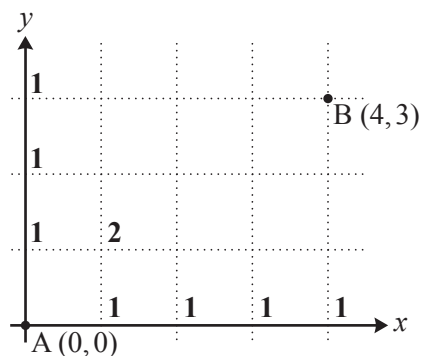

Fig. 4

The final step on a minimum distance route from A to the point $(2, 1)$ must be either from $(2, 0)$ to $(2, 1)$ or from $(1, 1)$ to $(2, 1)$. There is 1 minimum distance route from A to $(2, 0)$ and there are 2 minimum distance routes from A to $(1, 1)$. Each of these routes can be continued to $(2, 1)$ in only one way. Since all of these routes are different, the number of minimum distance routes from A to $(2, 1)$ is 3. 45

This reasoning can be extended to other grid points. The notation $n(p, q)$ is used to denote the number of minimum distance routes from $(0, 0)$ to (p, q) , where p and q are non-negative integers. The following rules apply for $p \geq 1, q \geq 1$.

$$n(p, 0) = 1$$

$$n(0, q) = 1$$

$$n(p, q) = n(p-1, q) + n(p, q-1)$$

50

These rules give the numbers of minimum distance routes shown in Fig. 5.

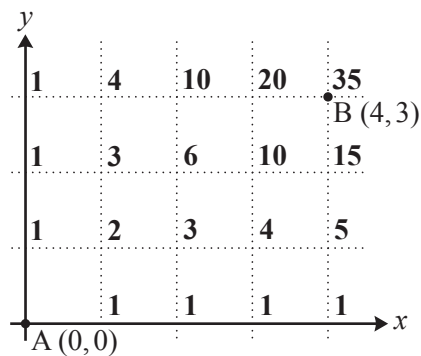

Fig. 5

So the answer to the question of how many minimum distance routes there are from $A(0, 0)$ to $B(4, 3)$ is 35. 55

Generalised taxicab geometry

The mathematical model of taxicab geometry described so far has been motivated by a system of roads and junctions. In this system there is a finite number of uniformly spaced parallel and perpendicular roads and all journeys start and end at junctions.

The mathematical ideas can be generalised by defining the taxicab distance for any two points in the x - y plane. In this generalised version, the points are not necessarily grid points. 60

Fig. 6 shows two points, $R(x_1, y_1)$ and $S(x_2, y_2)$, in the x - y plane.

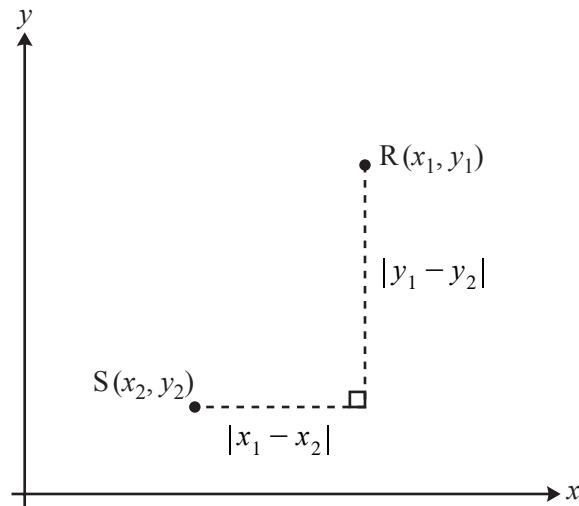

Fig. 6

The taxicab distance, $t(R, S)$, is defined as $|x_1 - x_2| + |y_1 - y_2|$. Thus the taxicab distance is still defined as the sum of the distances between the points in the x - and y -directions.

For example, the taxicab distance between the points with coordinates $(2.1, 1)$ and $(3.9, 4.3)$ is 65

$$\begin{aligned} & |2.1 - 3.9| + |1 - 4.3| \\ &= |-1.8| + |-3.3| \\ &= 1.8 + 3.3 \\ &= 5.1. \end{aligned}$$

Similarly the taxicab distance between $(-1.1, 1.4)$ and $(3.2, -0.8)$ is 70

$$|-1.1 - 3.2| + |1.4 - (-0.8)| = |-4.3| + |2.2| = 4.3 + 2.2 = 6.5.$$

This definition of distance produces some surprising geometric results, as will be seen below.

Fig. 7 shows a fixed point $C(2,3)$ and the locus of the point P satisfying $t(P,C) = 5$. The coordinates of every point $P(x,y)$ on this locus satisfy the equation $|x - 2| + |y - 3| = 5$.

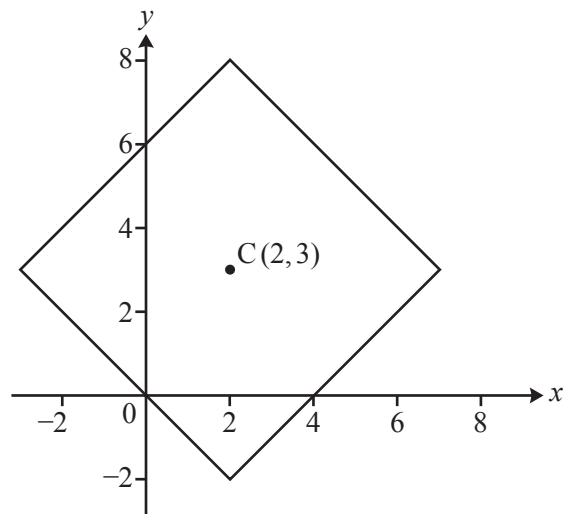

Fig. 7

Since all points are at a fixed taxicab distance from C , this is a taxicab 'circle' in this geometry! The circle has a taxicab 'radius' of 5. 75

Furthermore, adding a second taxicab circle with centre $(2,0)$ and radius 2 shows that in generalised taxicab geometry two different circles can have an infinite number of points in common!

Now consider the locus of a point Q which is 'equidistant' from two fixed points $A(0,0)$ and $B(8,6)$.

Fig. 8.1 shows the set of points Q satisfying $d(Q,A) = d(Q,B)$; this is the familiar perpendicular bisector of the line segment AB . 80

Fig. 8.2 shows the set of points Q satisfying $t(Q,A) = t(Q,B)$; so in generalised taxicab geometry the locus is quite different.

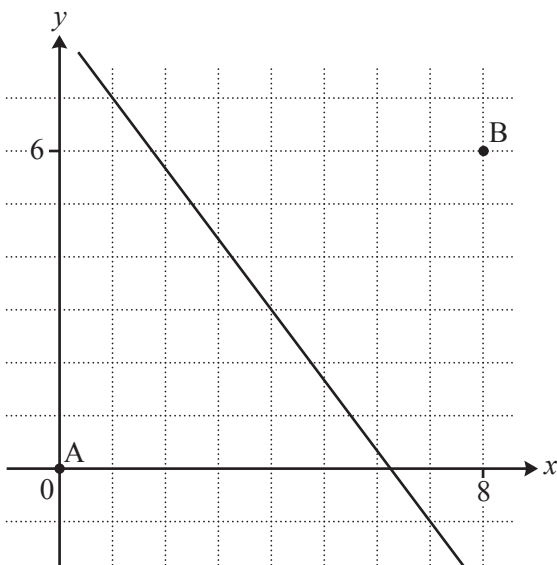

Fig. 8.1

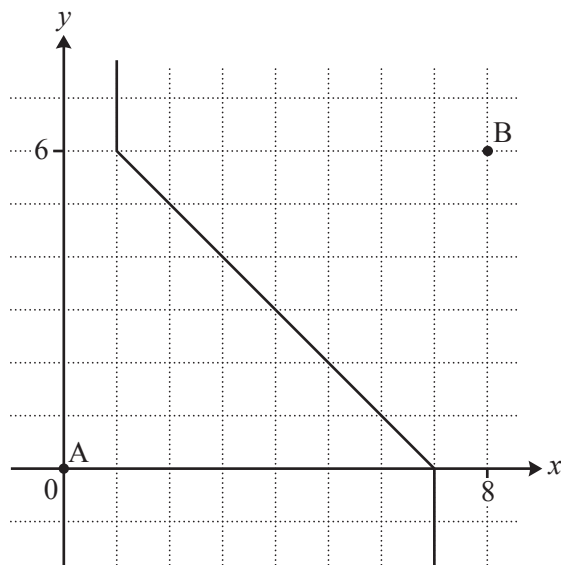

Fig. 8.2

Conclusion

In the natural world it is often appropriate to apply Pythagoras's Theorem to calculate the distance between two points. However, in urban geography, where there are obstacles such as buildings to be considered, taxicab geometry is often a more useful mathematical model. 85

In this article several simplifying assumptions have been made. For example, the imaginary town is laid out in a square grid, all roads are traversable in both directions and that the rate of progress along every route is uniform. Although these clearly do not exactly match any real cities, Fig. 9 below, a map of Manhattan in New York, suggests that, for some cities, some form of taxicab geometry can provide a good mathematical model. 90

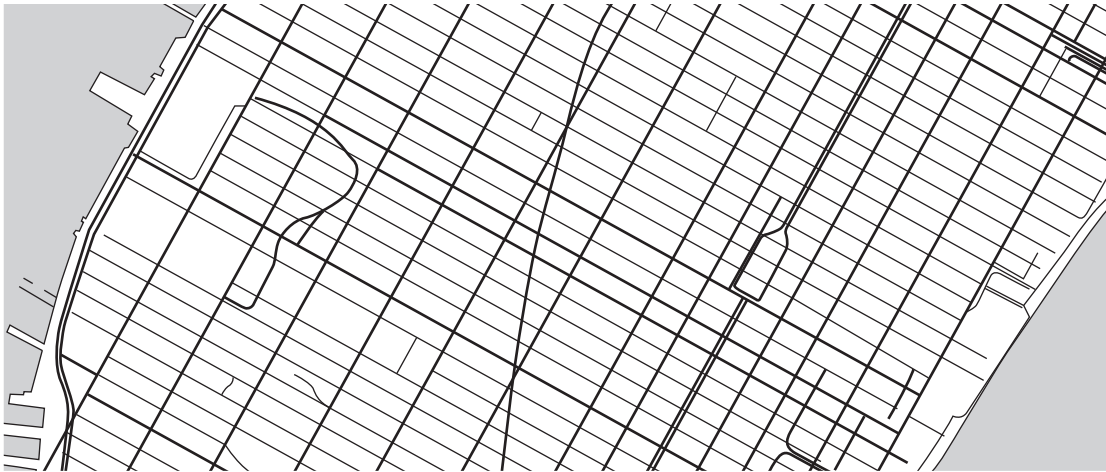

Fig. 9

Copyright Information

OCR is committed to seeking permission to reproduce all third-party content that it uses in its assessment materials. OCR has attempted to identify and contact all copyright holders whose work is used in this paper. To avoid the issue of disclosure of answer-related information to candidates, all copyright acknowledgements are reproduced in the OCR Copyright Acknowledgements Booklet. This is produced for each series of examinations and is freely available to download from our public website (www.ocr.org.uk) after the live examination series.

If OCR has unwittingly failed to correctly acknowledge or clear any third-party content in this assessment material, OCR will be happy to correct its mistake at the earliest possible opportunity.

For queries or further information please contact the Copyright Team, First Floor, 9 Hills Road, Cambridge CB2 1GE.

OCR is part of the Cambridge Assessment Group; Cambridge Assessment is the brand name of University of Cambridge Local Examinations Syndicate (UCLES), which is itself a department of the University of Cambridge.

Friday 18 January 2013 – Afternoon

A2 GCE MATHEMATICS (MEI)

4754/01B Applications of Advanced Mathematics (C4) Paper B: Comprehension

QUESTION PAPER

Candidates answer on the Question Paper.

OCR supplied materials:

- Insert (inserted)
- MEI Examination Formulae and Tables (MF2)

Other materials required:

- Scientific or graphical calculator
- Rough paper

Duration: Up to 1 hour



Candidate forename		Candidate surname	
-----------------------	--	----------------------	--

Centre number						Candidate number				
---------------	--	--	--	--	--	------------------	--	--	--	--

INSTRUCTIONS TO CANDIDATES

- The insert will be found in the centre of this document.
- Write your name, centre number and candidate number in the boxes above. Please write clearly and in capital letters.
- Use black ink. HB pencil may be used for graphs and diagrams only.
- Answer **all** the questions.
- Read each question carefully. Make sure you know what you have to do before starting your answer.
- Write your answer to each question in the space provided. Additional paper may be used if necessary but you must clearly show your candidate number, centre number and question number(s).
- Do **not** write in the bar codes.
- The insert contains the text for use with the questions.
- You are permitted to use a scientific or graphical calculator in this paper.
- Final answers should be given to a degree of accuracy appropriate to the context.

INFORMATION FOR CANDIDATES

- The number of marks is given in brackets [] at the end of each question or part question.
- You may find it helpful to make notes and do some calculations as you read the passage.
- You are **not** required to hand in these notes with your question paper.
- You are advised that an answer may receive **no marks** unless you show sufficient detail of the working to indicate that a correct method is being used.
- The total number of marks for this paper is **18**.
- This document consists of **8** pages. Any blank pages are indicated.

BLANK PAGE

PLEASE DO NOT WRITE ON THIS PAGE

- 1 On the grid below mark all three possible positions of the point P with integer coordinates for which $t(P, X) = 4$ and $t(P, Y) = 3$. [3]

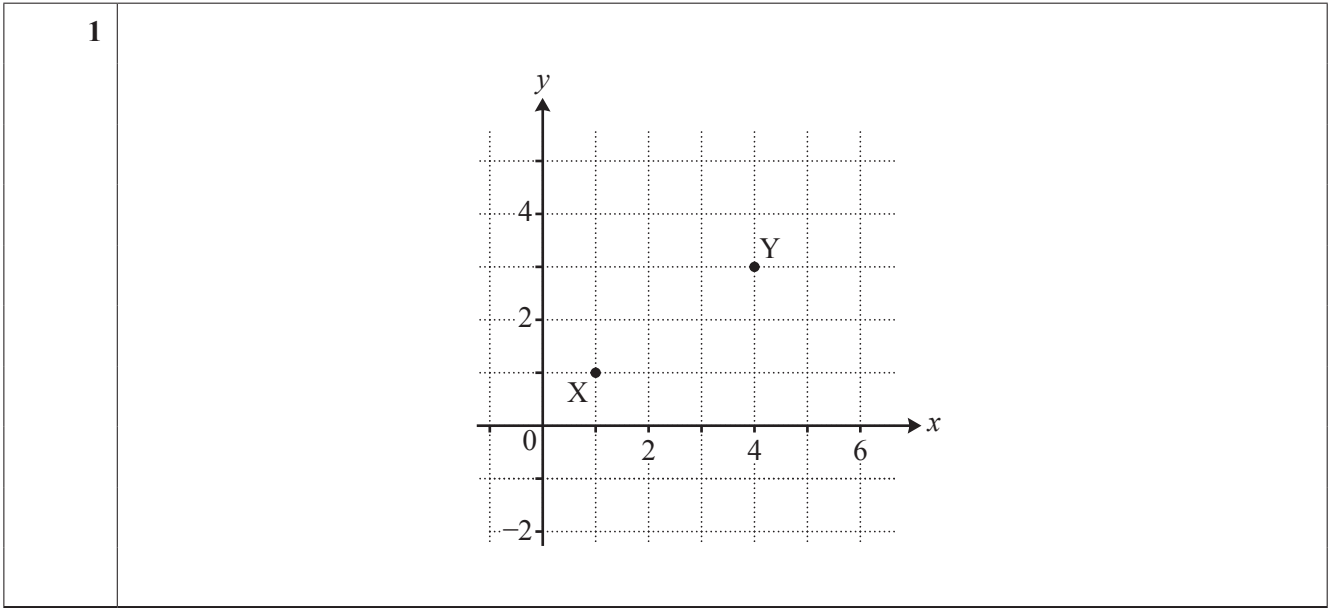

- 2 This question is concerned with generalised taxicab geometry.

On the grid below, show the locus of a point P where $t(P, A) = t(P, B)$. [3]

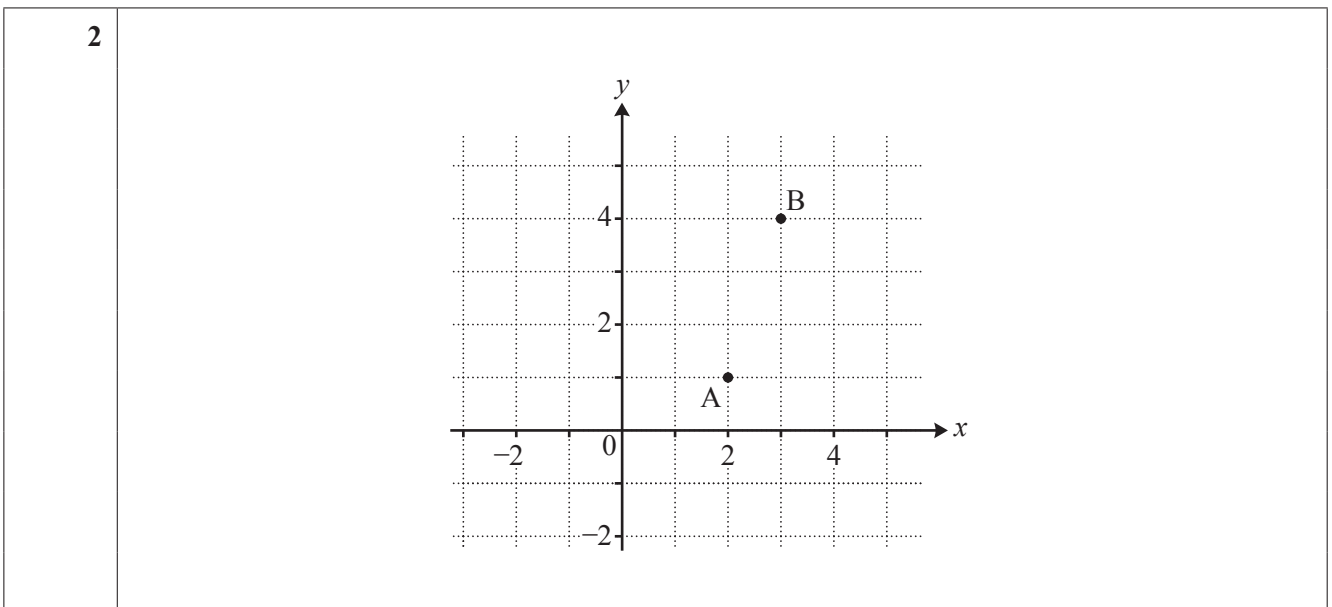

- 3 (i) Describe the following locus of a point P, using the notation $t(P,A)$ and $t(P,B)$ as appropriate.

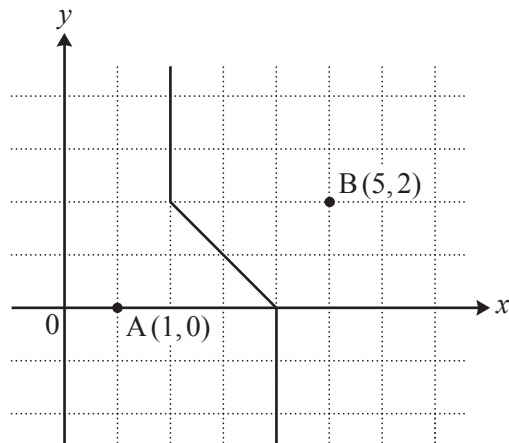

[1]

- (ii) Describe the following locus of a point P, using the notation $t(P,A)$ as appropriate.

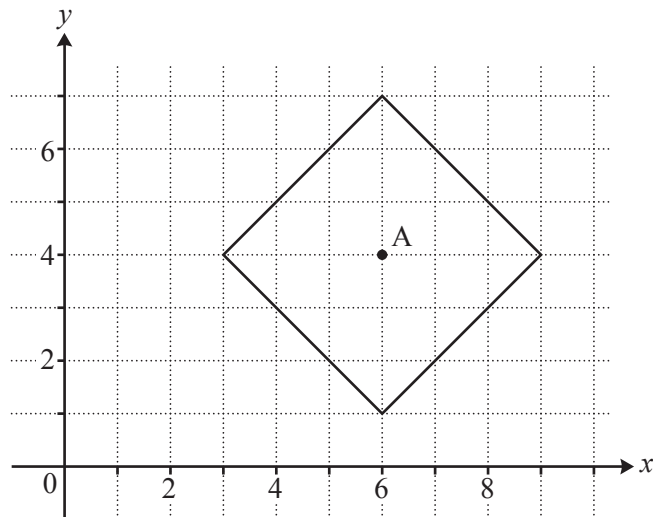

[1]

3 (i)	
3 (ii)	

PLEASE DO NOT WRITE IN THIS SPACE

4 Referring to Fig. 5, or otherwise, find the value of $n(4,4)$.

[2]

4	

5 In lines 54 and 55 it says there are 35 minimum distance routes from A $(0,0)$ to B $(4,3)$. Determine how many of these routes pass through the point with coordinates $(3,2)$, explaining your reasoning. [2]

5	

6 Fig. 7 is reproduced below.

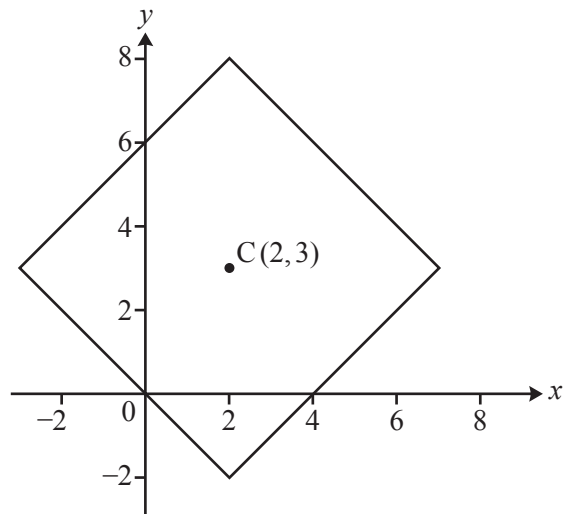

(i) Two points on this locus have x -coordinate -0.7 . Write down the coordinates of each of these points. [2]

(ii) In lines 77 to 78 it says “adding a second taxicab circle with centre $(2,0)$ and radius 2 shows that in generalised taxicab geometry two different circles can have an infinite number of points in common!”

On the copy of Fig. 7 given below, draw the taxicab circle with centre $(2,0)$ and radius 2. [1]

6 (i)	
6 (ii)	

- 7 In lines 23 and 24 it says that “if the Pythagorean distance between two points A and B is $d(A,B)$ then the taxicab distance satisfies the inequalities $d(A,B) \leq t(A,B) \leq \sqrt{2} \times d(A,B)$.”

This question is about using this result in generalised taxicab geometry.

(i) Given that A is the point $(0,0)$, describe all possible positions of B for which $d(A,B) = t(A,B)$. [1]

(ii) Given that A is the point $(0,0)$, describe all possible positions of B for which $t(A,B) = \sqrt{2} \times d(A,B)$. [2]

7(i)	
7(ii)	

Copyright Information

OCR is committed to seeking permission to reproduce all third-party content that it uses in its assessment materials. OCR has attempted to identify and contact all copyright holders whose work is used in this paper. To avoid the issue of disclosure of answer-related information to candidates, all copyright acknowledgements are reproduced in the OCR Copyright Acknowledgements Booklet. This is produced for each series of examinations and is freely available to download from our public website (www.ocr.org.uk) after the live examination series.

If OCR has unwittingly failed to correctly acknowledge or clear any third-party content in this assessment material, OCR will be happy to correct its mistake at the earliest possible opportunity.

For queries or further information please contact the Copyright Team, First Floor, 9 Hills Road, Cambridge CB2 1GE.

OCR is part of the Cambridge Assessment Group; Cambridge Assessment is the brand name of University of Cambridge Local Examinations Syndicate (UCLES), which is itself a department of the University of Cambridge.

Thursday 13 June 2013 – Morning

A2 GCE MATHEMATICS (MEI)

**4754/01B Applications of Advanced Mathematics (C4) Paper B: Comprehension
QUESTION PAPER**

Candidates answer on the Question Paper.

OCR supplied materials:

- Insert (inserted)
- MEI Examination Formulae and Tables (MF2)

Other materials required:

- Scientific or graphical calculator
- Rough paper

Duration: Up to 1 hour



Candidate forename		Candidate surname	
-----------------------	--	----------------------	--

Centre number						Candidate number				
---------------	--	--	--	--	--	------------------	--	--	--	--

INSTRUCTIONS TO CANDIDATES

- The Insert will be found in the centre of this document.
- Write your name, centre number and candidate number in the boxes above. Please write clearly and in capital letters.
- Use black ink. HB pencil may be used for graphs and diagrams only.
- Answer **all** the questions.
- Read each question carefully. Make sure you know what you have to do before starting your answer.
- Write your answer to each question in the space provided. Additional paper may be used if necessary but you must clearly show your candidate number, centre number and question number(s).
- Do **not** write in the bar codes.
- The Insert contains the text for use with the questions.
- You are permitted to use a scientific or graphical calculator in this paper.
- Final answers should be given to a degree of accuracy appropriate to the context.

INFORMATION FOR CANDIDATES

- The number of marks is given in brackets [] at the end of each question or part question.
- You may find it helpful to make notes and to do some calculations as you read the passage.
- You are **not** required to hand in these notes with your Question Paper.
- You are advised that an answer may receive **no marks** unless you show sufficient detail of the working to indicate that a correct method is being used.
- The total number of marks for this paper is **18**.
- This document consists of **8** pages. Any blank pages are indicated.

1 The diagram is a copy of Fig. 4.

R is a place with latitude 45° north and longitude 60° west. Show the position of R on the diagram.

M is the sub-solar point. It is on the Greenwich meridian and the declination of the sun is $+20^\circ$. Show the position of M on the diagram. [2]

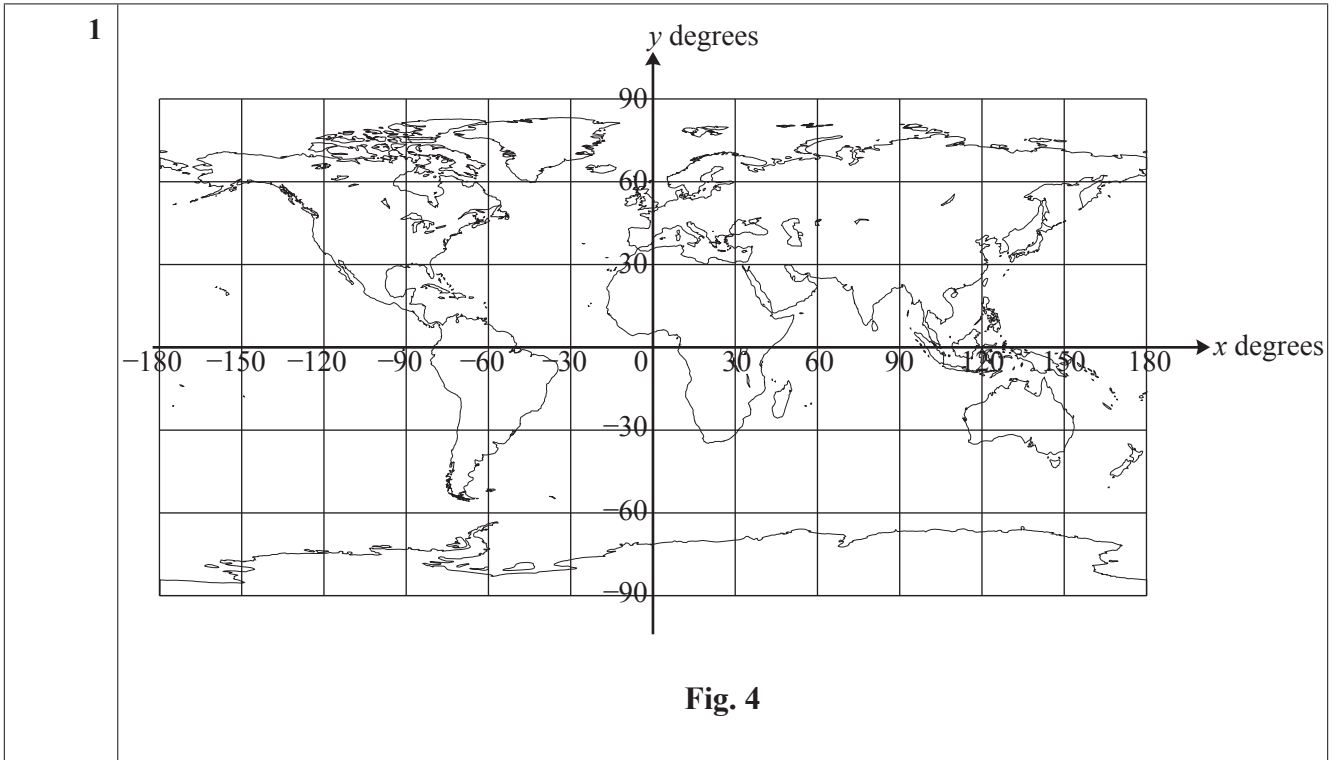

2 Use Fig. 8 to estimate the difference in the length of daylight between places with latitudes of 30° south and 60° south on the day for which the graph applies. [3]

2	
----------	--

3 The graph is a copy of Fig. 6.

The article says that it shows the terminator in the cases where the sun has declination 10° north, 1° north, 5° south and 15° south.

Identify which curve (A, B, C or D) relates to which declination.

[2]

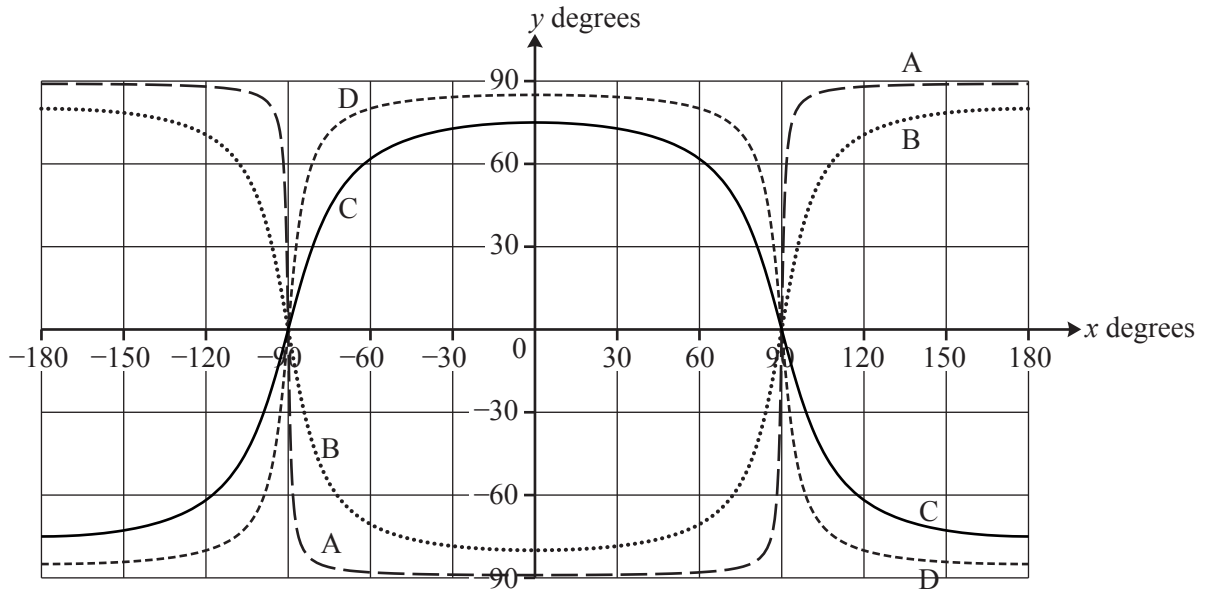

Fig. 6

3	10° north:
	1° north:
	5° south:
	15° south:

4 In lines 94 and 95 the article says

“Fig. 8 shows you that at latitude 60° north the terminator passes approximately through time +9 hours and -9 hours so that there are about 18 hours of daylight.”

Use Equation (4) to check the accuracy of the figure of 18 hours.

[4]

4	

5 (i) Use Equation (3) to calculate the declination of the sun on February 2nd. [3]

(ii) The town of Boston, in Lincolnshire, has latitude 53° north and longitude 0° .

Calculate the time of sunset in Boston on February 2nd.

Give your answer in hours and minutes using the 24-hour clock. [4]

5 (i)	
5 (ii)	

BLANK PAGE

PLEASE DO NOT WRITE ON THIS PAGE

BLANK PAGE

PLEASE DO NOT WRITE ON THIS PAGE

PLEASE DO NOT WRITE ON THIS PAGE



Copyright Information

OCR is committed to seeking permission to reproduce all third-party content that it uses in its assessment materials. OCR has attempted to identify and contact all copyright holders whose work is used in this paper. To avoid the issue of disclosure of answer-related information to candidates, all copyright acknowledgements are reproduced in the OCR Copyright Acknowledgements Booklet. This is produced for each series of examinations and is freely available to download from our public website (www.ocr.org.uk) after the live examination series.

If OCR has unwittingly failed to correctly acknowledge or clear any third-party content in this assessment material, OCR will be happy to correct its mistake at the earliest possible opportunity.

For queries or further information please contact the Copyright Team, First Floor, 9 Hills Road, Cambridge CB2 1GE.

OCR is part of the Cambridge Assessment Group; Cambridge Assessment is the brand name of University of Cambridge Local Examinations Syndicate (UCLES), which is itself a department of the University of Cambridge.

Thursday 13 June 2013 – Morning

A2 GCE MATHEMATICS (MEI)

4754/01B Applications of Advanced Mathematics (C4) Paper B: Comprehension

INSERT



INFORMATION FOR CANDIDATES

- This Insert contains the text for use with the questions.
- This document consists of **8** pages. Any blank pages are indicated.

INSTRUCTION TO EXAMS OFFICER/INVIGILATOR

- Do not send this Insert for marking; it should be retained in the centre or recycled. Please contact OCR Copyright should you wish to re-use this document.

Day-Night Maps

On many inter-continental flights you will see a *day-night map* displayed, like that in Fig. 1. It shows those parts of the earth that are in daylight and those that are in darkness. Such maps usually show the position of the aeroplane. They also, as in this case, often show the point that is immediately under the sun; at that point the sun is directly overhead.

5

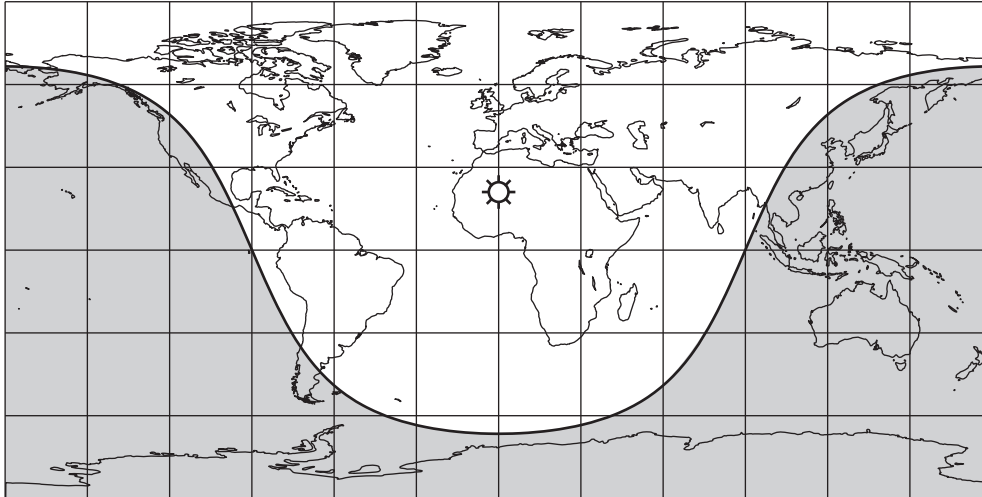

Fig. 1

Fig. 1 shows the day-night map when it is mid-day in the United Kingdom on mid-summer's day in the northern hemisphere.

Modelling assumptions

Fig. 2 illustrates the earth as a 3-dimensional object being illuminated by the sun. At any time the sun is shining on approximately half of the earth's surface but not on the other half. The two regions are separated by a circle on the earth's surface called the *terminator*. This is represented in Fig. 1 as the curve separating the light and dark regions.

10

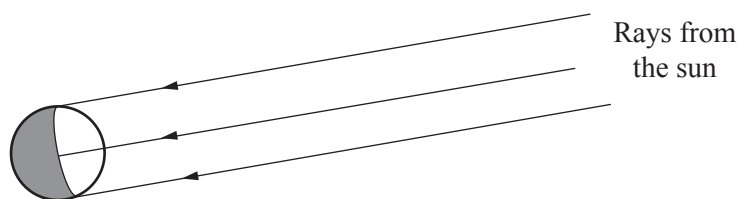

Fig. 2

In this article, a number of modelling assumptions are made to simplify the situation.

- The sun is taken to be a point so that at any time it is either above the horizon or below it, but never partly above and partly below.
- All light rays coming from the sun to the earth are parallel.
- The effects of refraction (bending of the light by the earth's atmosphere) are negligible.
- The earth is a perfect sphere.

15

The effects of these assumptions are that, at any time, exactly (and not approximately) half of the earth's surface is being illuminated by the sun and there is no twilight; at any place, it is either day or night. None of the assumptions is actually quite true, but they are all close enough to provide a good working model.

20

Fig. 3, below, is in two dimensions; it shows a section of the earth through its centre, O, in the same plane as the sun.

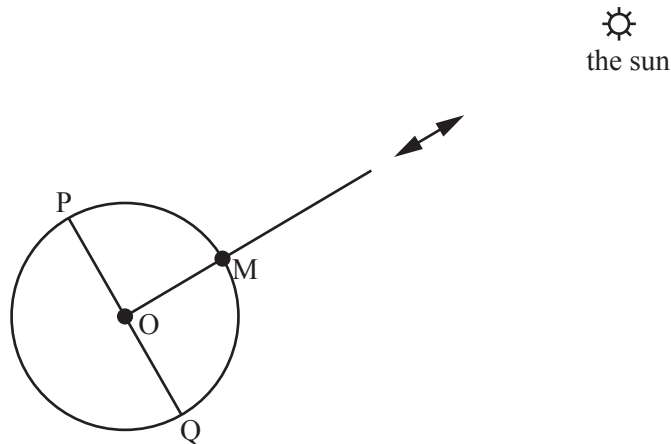

Fig. 3

The line from the centre of the earth to the sun cuts the surface of the earth at the *sub-solar point*, M. If you were standing at M you would see the sun directly overhead. On a typical day-night map there is a picture of the sun at the sub-solar point. 25

The points P and Q are on the terminator: $\angle POM = \angle QOM = 90^\circ$. If you were standing at P or Q it would either be the moment of sunrise or the moment of sunset for you.

The cartesian equation of the terminator

Fig. 4 shows the map of the world with x - and y -axes superimposed. 30

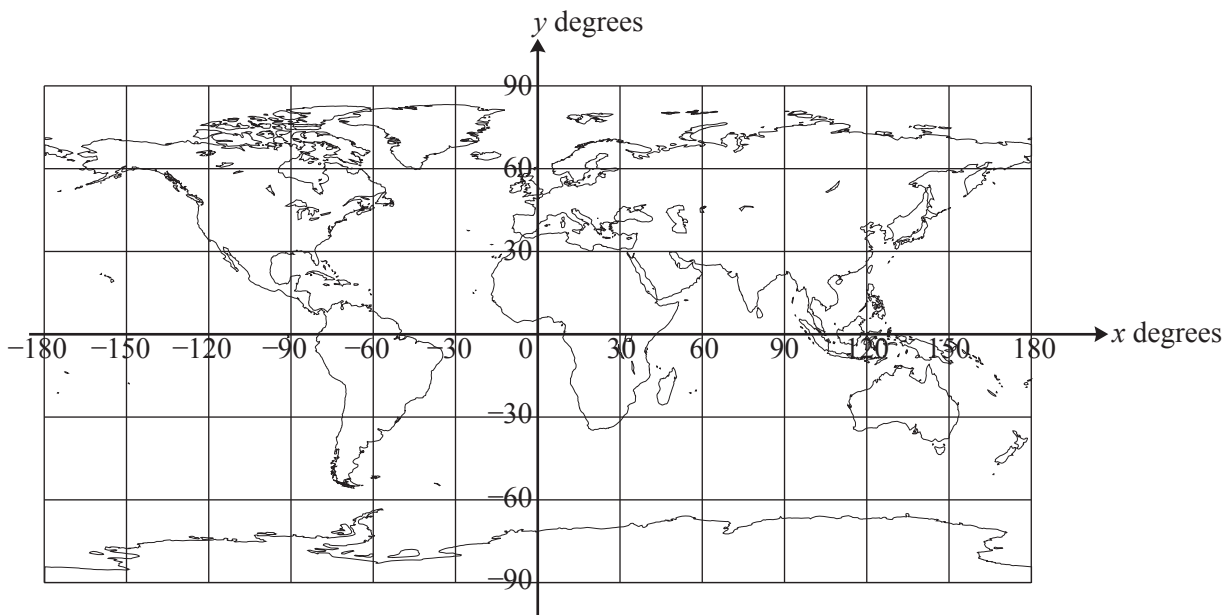

Fig. 4

On these axes:

- x represents longitude, going from -180° (180° west) to $+180^\circ$ (180° east),
- y represents latitude, going from -90° (90° south) to $+90^\circ$ (90° north).

The lines parallel to the x -axis are called lines of latitude. On the earth's surface they are actually circles. The x -axis itself is the equator. 35

The lines parallel to the y -axis are called lines of longitude, or *meridians*. Each meridian is actually a semicircle along the earth's surface joining the north pole and the south pole. The y -axis is the zero meridian; it passes through Greenwich in London and so is called the Greenwich meridian.

The y -coordinate of the sub-solar point is its latitude, measured in degrees, and is called the *declination* of the sun. In this article the declination of the sun is denoted by α . During a year, the value of α varies between $+23.44^\circ$ on mid-summer's day in the northern hemisphere and -23.44° on mid-winter's day. Fig. 1 shows the situation on mid-summer's day, when the sun is at its most northerly, and so $\alpha = 23.44^\circ$. 40

Using these axes, it is possible to show that the equation of the terminator on the map, for the time and day shown in Fig. 1, can be written as the cartesian equation

$$\tan y = -2.306 \cos x. \quad (1) \quad 45$$

This can also be written as

$$y = \arctan(-2.306 \cos x).$$

Fig. 5 shows this curve.

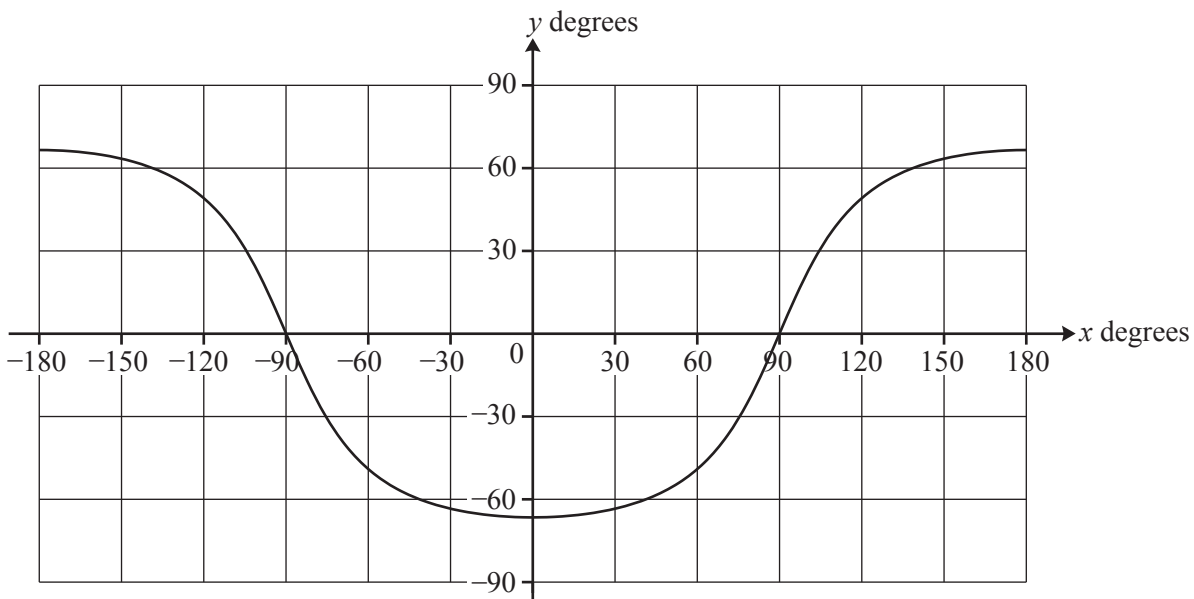

Fig. 5

When this curve is superimposed on the map of the world, and the correct region is shaded, the day-night map in Fig. 1 is produced. 50

The terminator is a circle on the earth's surface and so it is quite surprising that the curve in Fig. 5 looks nothing like a circle. There are two points to be made.

- The map in Fig. 4 is formed from a cylinder that has been cut along the line $x = \pm 180$ and laid flat. $x = +180$ and $x = -180$ are the same line. So the curve is continuous.
- The earth is a sphere and representing it on a cylinder causes distortion; this affects the shape of the curve on the map. In particular, the polar regions become very distorted, and, along with them, the circular shape of the terminator. 55

The representation used to draw a sphere on a flat sheet of paper is called the map's *projection*. There are very many different map projections; the one used for day-night maps is called *equiarectangular cylindrical* (or *plate carrée*).

60

The terminator at other times and on other dates

So far, only one time and day of the year has been considered, mid-day on mid-summer's day in the northern hemisphere when the declination of the sun is $+23.44^\circ$. What about other times of day? And other days of the year?

The answer to the question about different times of day is that, as the earth rotates, the sub-solar point moves along its circle of latitude and the terminator moves with it, keeping the same shape.

65

The question about other days of the year relates to the declination of the sun. On mid-summer's day, $\alpha = 23.44^\circ$. Equation (1) is $\tan y = -2.306 \cos x$; the number 2.306 arises because

$$\frac{1}{\tan 23.44^\circ} = 2.306.$$

For a general value of α , the number 2.306 is replaced by

70

$$\frac{1}{\tan \alpha}$$

and so the equation of the terminator can be written in general form as

$$\tan y = -\frac{1}{\tan \alpha} \cos x. \quad (2)$$

Equation (2) makes it possible to draw a graph illustrating the terminator for any possible declination of the sun. Fig. 6 shows the terminator in the cases where the sun has declination 10° north, 1° north, 5° south and 15° south. In each case the time is mid-day on the Greenwich meridian.

75

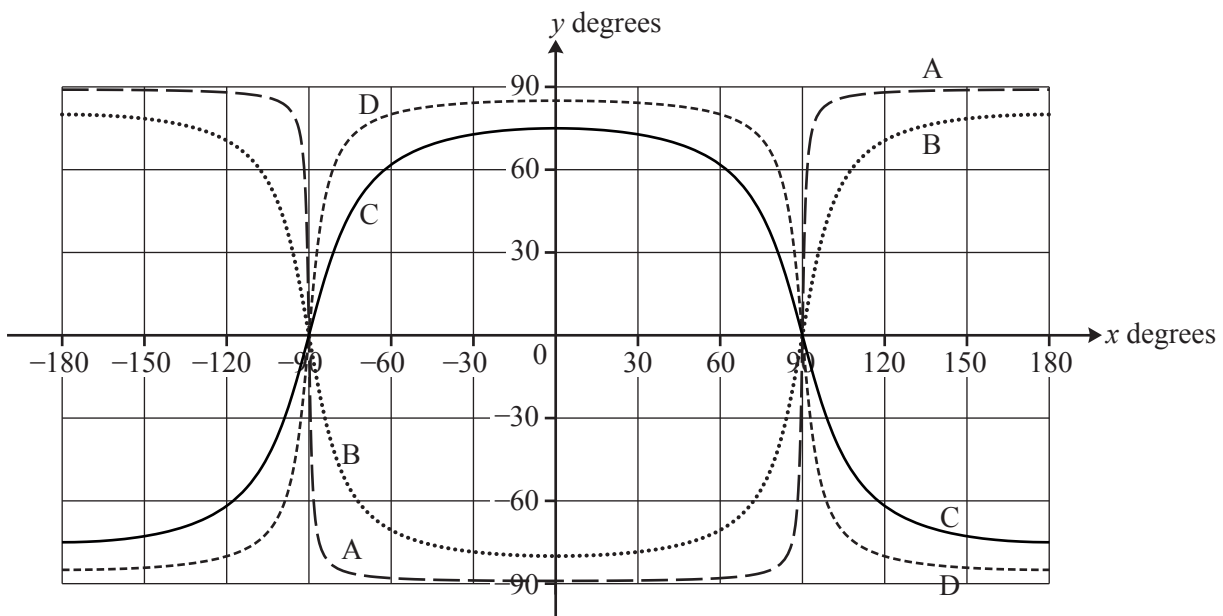

Fig. 6

The declination of the sun

In Fig. 1 the sun is at its most northerly point with declination $+23.44^\circ$. On mid-winter's day its declination is -23.44° . To good approximation, the value of the declination follows a sine curve between these two values, as shown in Fig. 7. Day 1 is January 1st.

80

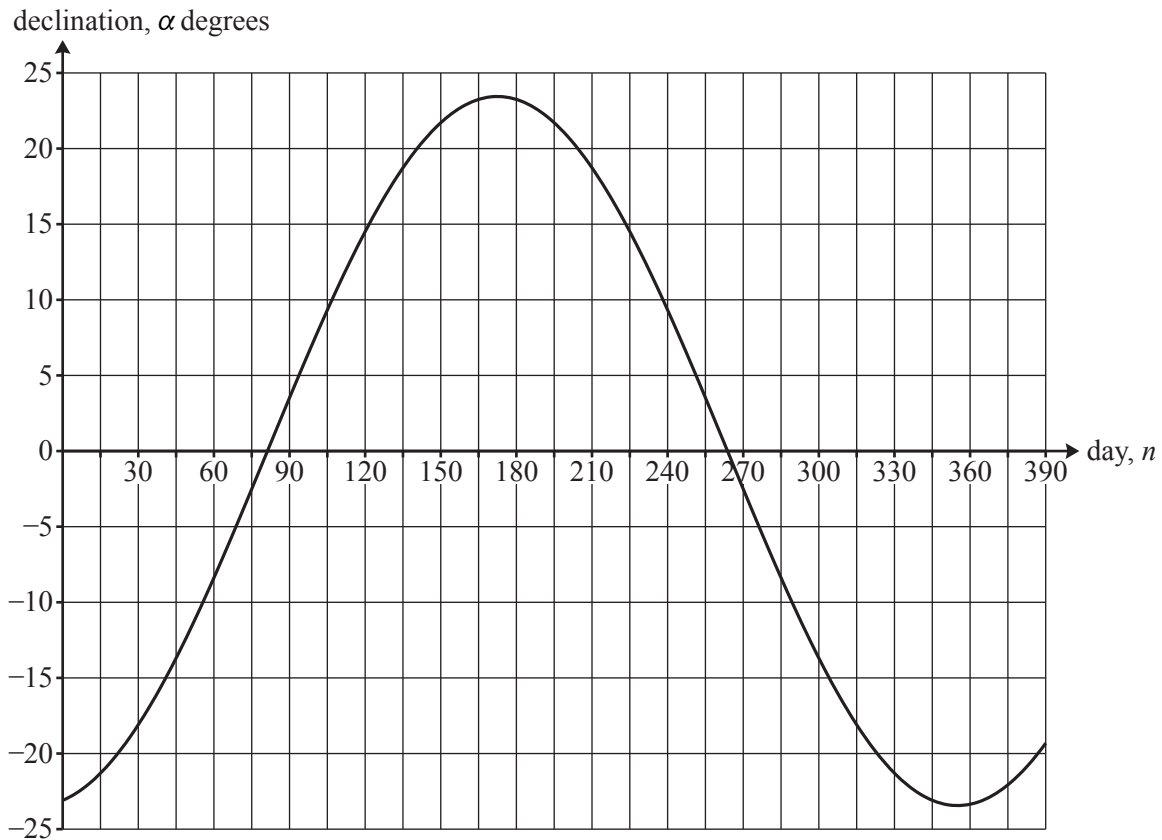

Fig. 7

The equation of the curve in Fig. 7 is

$$\alpha = -23.44 \times \cos\left(\frac{360}{365} \times (n + 10)\right). \quad (3)$$

(This approximation is based on the modelling assumption that the orbit of the earth around the sun is a circle; it is actually an ellipse.)

Hours of daylight

85

If you travel north when it is summer in the northern hemisphere, you will notice that the days become longer and the nights shorter. The graph of the terminator allows you to see how this happens.

The earth rotates on its axis once every day. So it turns through 360° every 24 hours or 15° per hour. So every 15° of longitude (ie along the x -axis in Fig. 5) corresponds to 1 hour of time.

Fig. 8 is the same as Fig. 5 (the declination of the sun is $+23.44^\circ$) but the horizontal axis represents the time difference from Greenwich, measured in hours, rather than longitude measured in degrees. 90

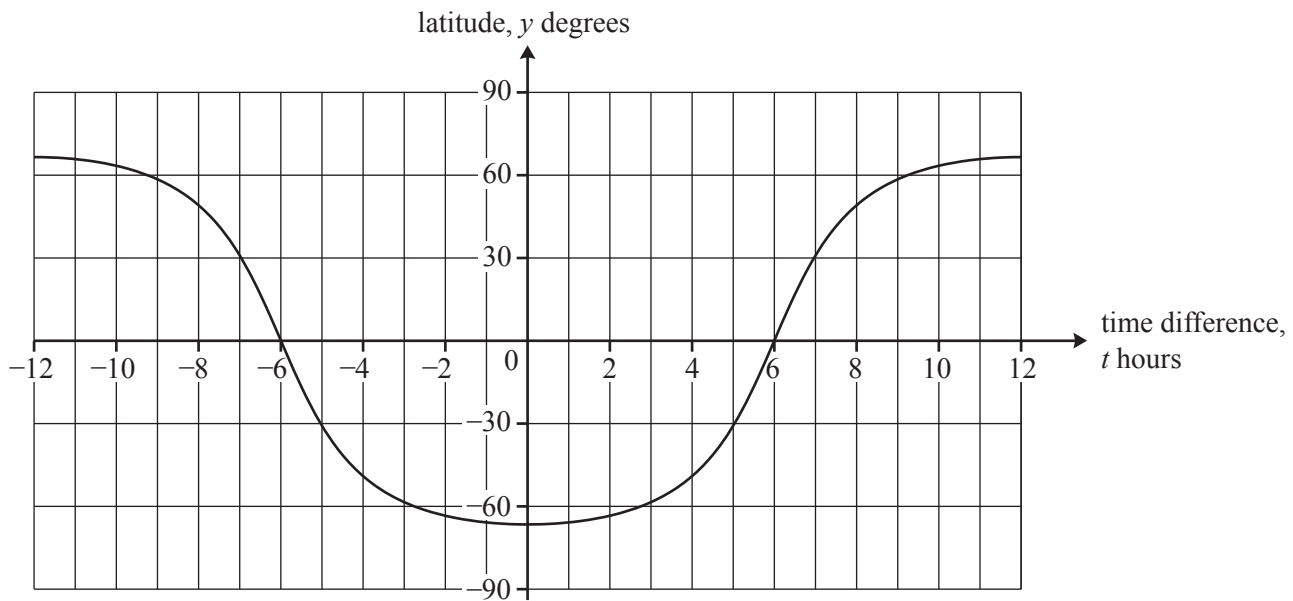

Fig. 8

The graph in Fig. 8 shows y against t . Since $x = 15t$, the equation of the terminator can be written as

$$\tan y = -\frac{1}{\tan \alpha} \cos(15t). \quad (4)$$

Fig. 8 shows you that at latitude 60° north the terminator passes approximately through time $+9$ hours and -9 hours so that there are about 18 hours of daylight. Oslo has latitude 60° north. 95

You can also see that at latitude 30° north there are about 14 hours of daylight on this day of the year. Cairo has latitude 30° north.

So Oslo has about 4 more hours of daylight than Cairo on this day.

At the start of the article, it was stated that one effect of the modelling assumptions is to ignore twilight. This is the time when the sun is just below the horizon. The effect of twilight is particularly noticeable in places with high latitudes, for example Oslo, in the summer so that it is nearly light for even longer. 100

**Copyright Information**

OCR is committed to seeking permission to reproduce all third-party content that it uses in its assessment materials. OCR has attempted to identify and contact all copyright holders whose work is used in this paper. To avoid the issue of disclosure of answer-related information to candidates, all copyright acknowledgements are reproduced in the OCR Copyright Acknowledgements Booklet. This is produced for each series of examinations and is freely available to download from our public website (www.ocr.org.uk) after the live examination series.

If OCR has unwittingly failed to correctly acknowledge or clear any third-party content in this assessment material, OCR will be happy to correct its mistake at the earliest possible opportunity.

For queries or further information please contact the Copyright Team, First Floor, 9 Hills Road, Cambridge CB2 1GE.

OCR is part of the Cambridge Assessment Group; Cambridge Assessment is the brand name of University of Cambridge Local Examinations Syndicate (UCLES), which is itself a department of the University of Cambridge.